

**DRAFT**  
NOT FOR CONSTRUCTION

RECOMMENDED FOR APPROVAL	DESIGN ENGINEER	DATE
DESIGNED: SGM	DRAWN: RJS	
CHECKED: KRC	CHECKED: KRC	

INDIANA  
DEPARTMENT OF TRANSPORTATION

PLAN SHEET  
LINE "S-4-C"  
STA. 47+31 TO STA. 51+70

HORIZONTAL SCALE 1" = 50'	BRIDGE FILE I64-120-10786
VERTICAL SCALE 1" = 10'	DESIGNATION 1700207
DWG. NO. ELECTRONIC	SHEETS 7 of 24
CONTRACT R-42570	PROJECT 1900162

tbieman  
 12/5/2022 9:34:38 AM  
 model: PP-03 [Sheet]  
 file: p:\i\p\in\hmb.org\PMGreatLakes\Documents\Indianapolis\Projects\78704 INDOT-S I-64 ATL 00 CAD-ORD\Sheets\Bridge\Bridg No. 3 - I-64 EB over Quarry Road\1900162\_S\_F1003.dgn

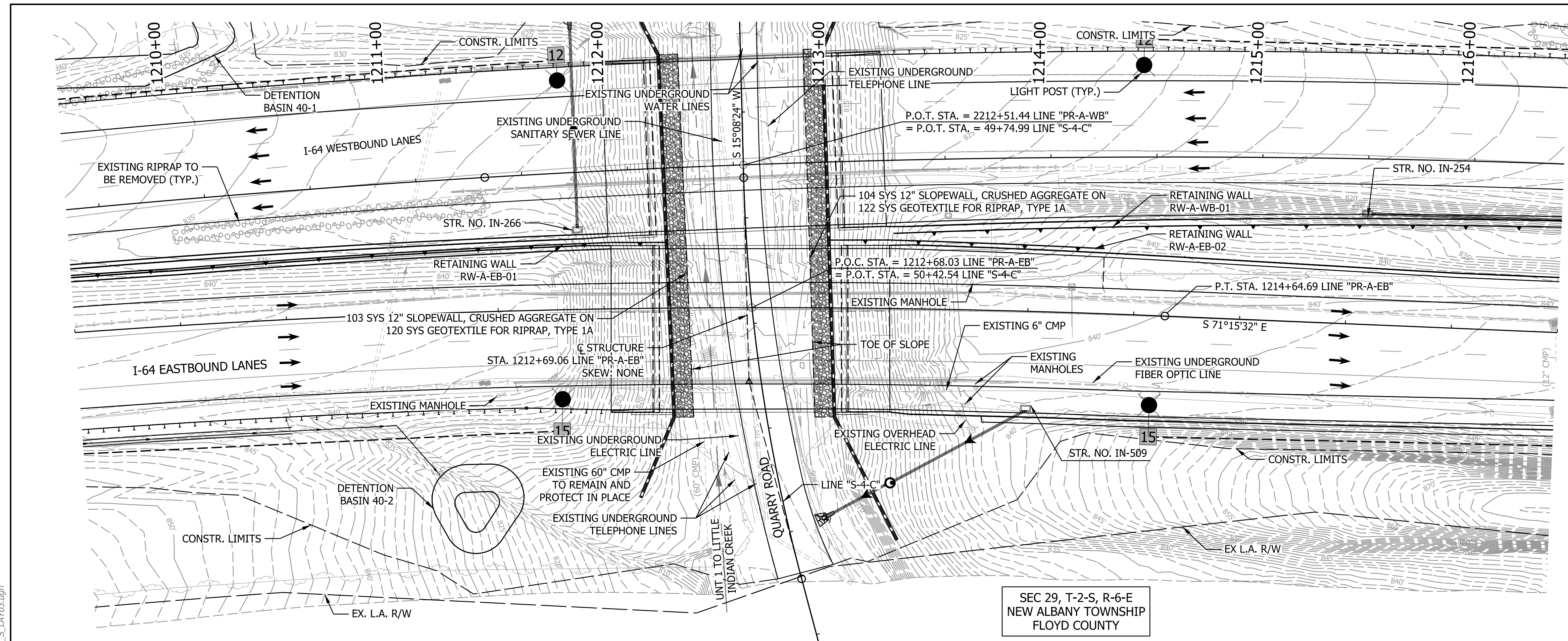

**EXISTING STRUCTURE**  
 EXISTING STRUCTURE (164-120-04984 JBEB) IS A THREE-SPAN (60'-6 1/2", 61'-1" & 60'-6 1/2") PRESTRESSED CONCRETE COMPOSITE I-BEAM BRIDGE WITH A 40'-3" CLEAR ROADWAY. STRUCTURE IS TO BE REMOVED. EXISTING BRIDGE PLANS ON FILE WITH THE INDIANA DEPARTMENT OF TRANSPORTATION AS FILE NO. 164-120-04984 J, JAEB, & JBEB.

**EARTHWORK TABULATION**  
 FOR EARTHWORK SUMMARY, SEE ROAD PLANS DES NO. 1900162

**NOTE TO REVIEWER**  
 UTILITY COORDINATION IS ONGOING AND ONCE FINALIZED THE EXISTING UTILITIES WILL BE IDENTIFIED AS "TO REMAIN & PROTECT-IN-PLACE", "RELOCATED", OR "ABANDONED" AS REQUIRED.

**HORIZONTAL CURVE DATA FOR LINE "PR-A-EB"**

P.I. 1210+01.41 LINE "PR-A-EB"  
 $\Delta = 11^\circ 50' 22.76''$  RT.  
 $D = 01^\circ 16' 23.66''$   
 $R = 4500.00'$   
 $T = 466.60'$   
 $L = 929.88'$   
 $E = 24.13'$   
 $SE = 3.40\%$

**HORIZONTAL CURVE DATA FOR LINE "S-4-C"**

P.I. 50+61.37 LINE "S-4-C"  
 $\Delta = 14^\circ 25' 54.66''$  LT.  
 $D = 07^\circ 00' 00.00''$   
 $R = 818.51'$   
 $T = 103.63'$   
 $L = 206.17'$   
 $E = 6.53'$   
 $SE = N.C.$

**NOTES:**

- FOR REFERENCE TIES AND BENCHMARKS, SEE ROAD PLANS DES NO. 1900162.
- FOR DITCH GRADES & GUARDRAIL LIMITS, SEE PLAN & PROFILE SHEET OF ROAD PLANS DES NO. 1900162.
- FOR RETAINING WALL RW-A-EB-01, RW-A-EB-02, AND RW-A-WB-01 DETAILS, SEE ROAD PLANS DES 1900162.
- FOR EXISTING AND PROPOSED UTILITIES, DRAINAGE, LIGHTING, SIGNING, AND ITS, SEE ROAD PLANS DES NO. 1900162.

**COMPOSITE PRESTRESSED CONCRETE BULB-TEE BEAM BRIDGE**  
 1 SPAN: 89'-0"  
 75'-9" CLEAR ROADWAY  
 SKEW: NONE  
 I-64 EB OVER QUARRY ROAD  
 FLOYD COUNTY

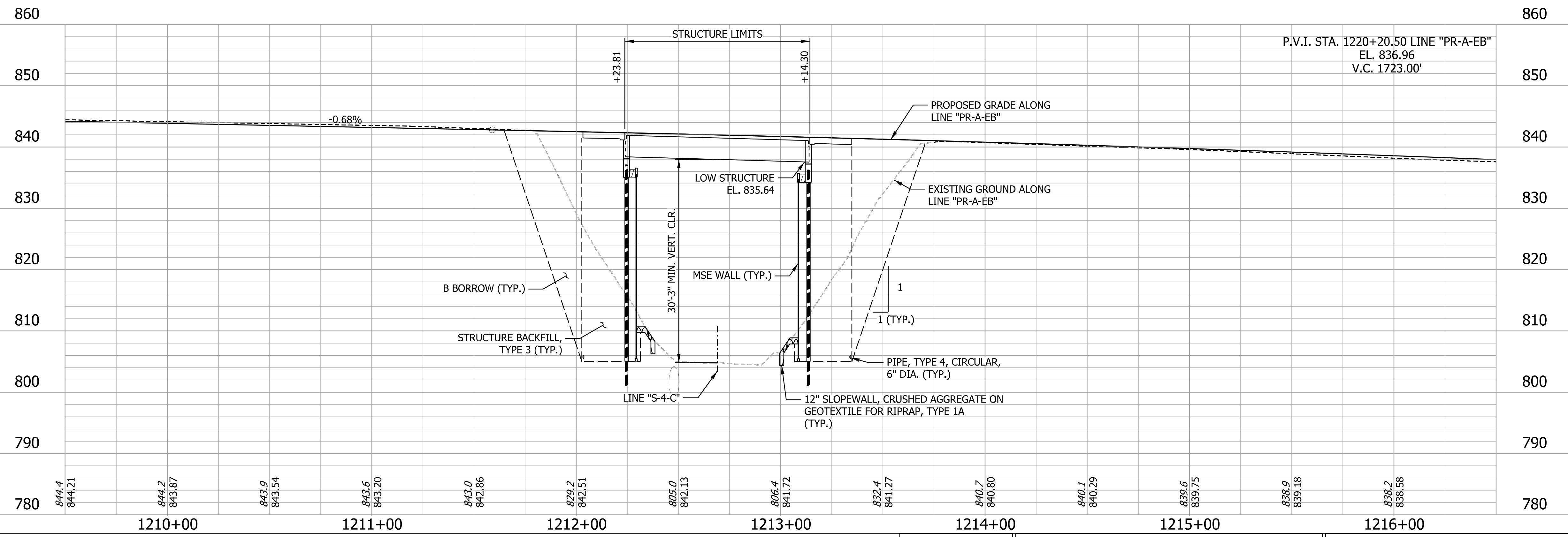

**DRAFT**  
 NOT FOR CONSTRUCTION

RECOMMENDED FOR APPROVAL	DESIGN ENGINEER	DATE
DESIGNED: PTT	DRAWN: PTT	
CHECKED: TMB	CHECKED: TMB	

INDIANA DEPARTMENT OF TRANSPORTATION  
 LAYOUT - LINE "PR-A-EB"

HORIZONTAL SCALE	BRIDGE FILE
1" = 30'	164-120-10786
VERTICAL SCALE	DESIGNATION
1" = 10'	1700207
SURVEY BOOK	SHEETS
ELECTRONIC	10 of 24
CONTRACT	PROJECT
R-42570	1900162

tbieman  
 12/5/2022; 9:35:24 AM  
 model: P1N-01 [Sheet]  
 file: p:\p1n-01\lmbb.org\p1n-01\INDOT-S I-64 ATL 00 CAD-ORD\Sheets\Bridge\Bridge No. 3 - I-64 EB over Quarry Road\1900162\_S\_LAY03.dgn

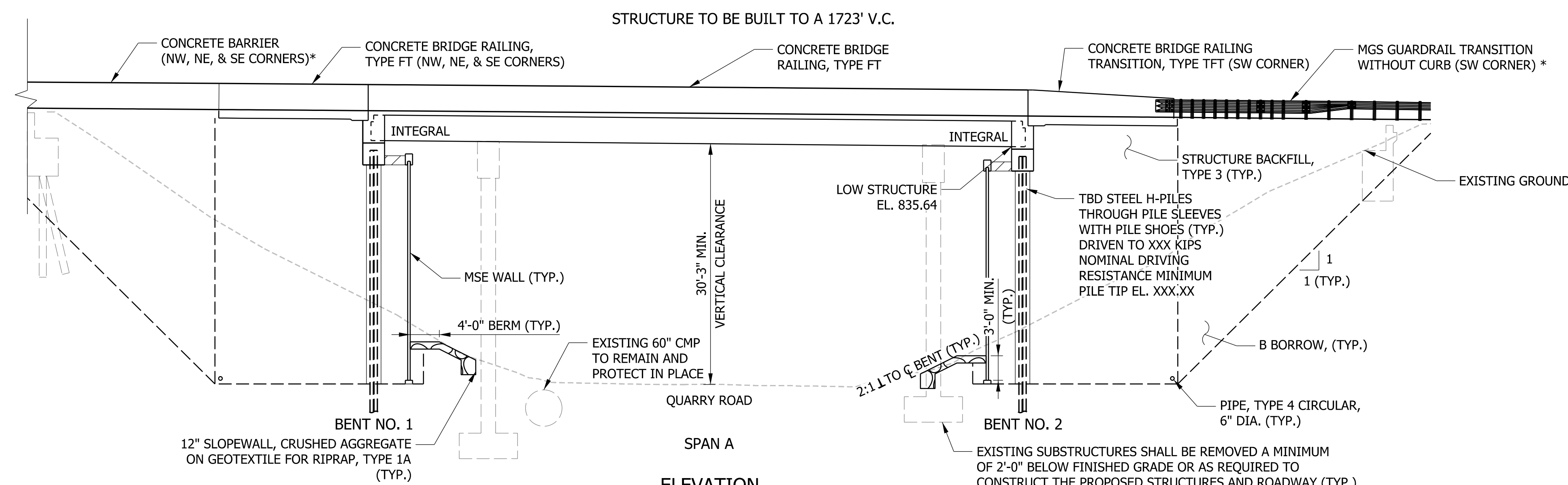

**NOTE TO REVIEWER**

THE GEOTECHNICAL INVESTIGATION IS CURRENTLY UNDERWAY AND PILE AND FOUNDATION INFORMATION WILL BE ADDED AT A FUTURE SUBMITTAL.

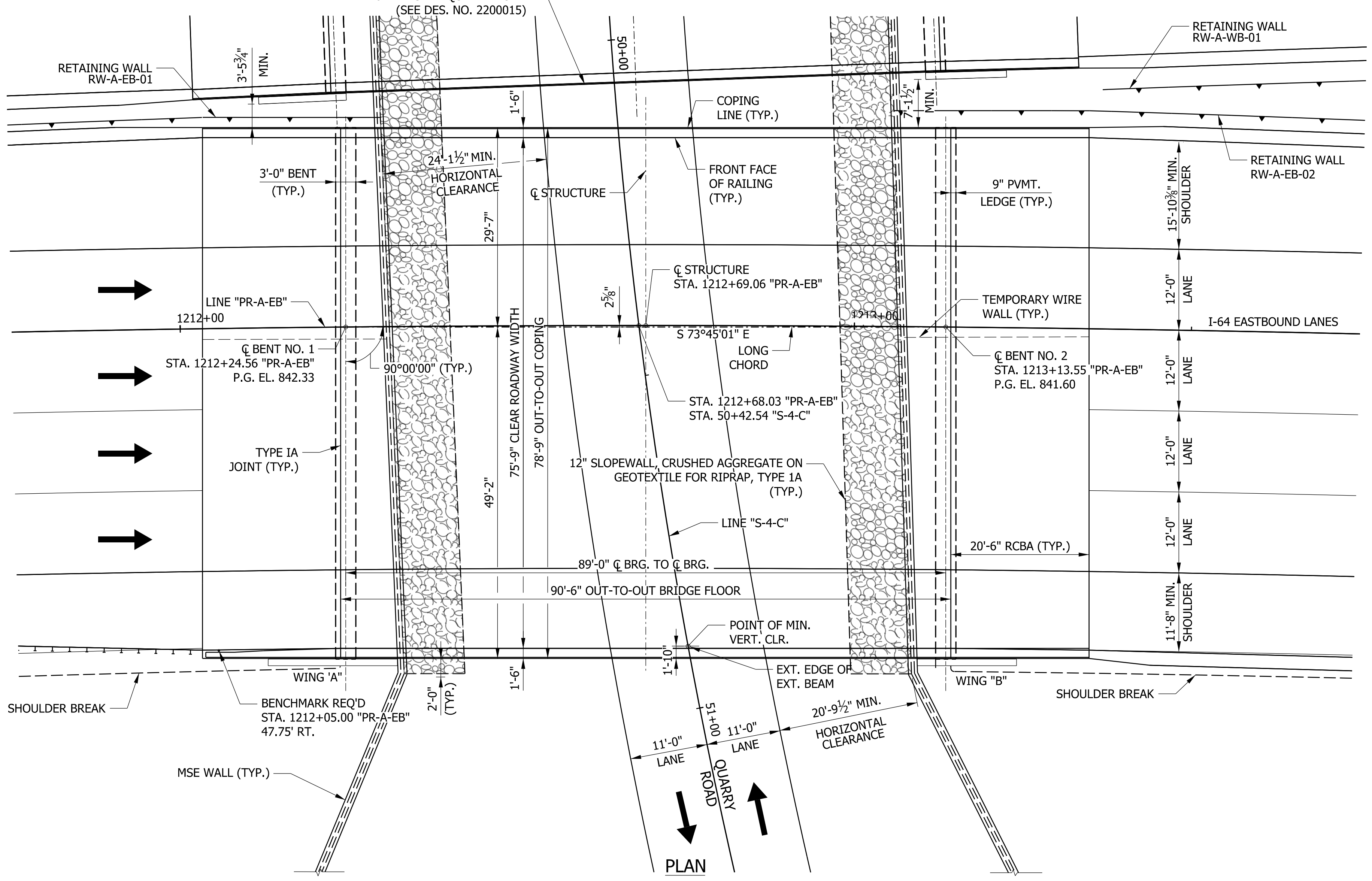
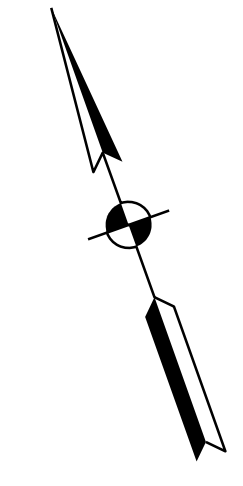

**LEGEND:**

NW DENOTES NORTHWEST  
 SW DENOTES SOUTHWEST  
 NE DENOTES NORTHEAST  
 SE DENOTES SOUTHEAST  
 \* ROADWAY ITEMS UNDER LEAD DES 1900162

**COMPOSITE PRESTRESSED CONCRETE  
 BULB-TEE BEAM BRIDGE  
 1 SPAN: 89'-0"  
 75'-9" CLEAR ROADWAY  
 SKEW: NONE  
 I-64 EB OVER QUARRY ROAD  
 FLOYD COUNTY**

tbieman  
 12/5/2022; 9:35:52 AM  
 model: PLN-01 [Sheet]  
 file: p:\i\p\m\h\m\p\m\g\Great\_Lakes\Documents\Indianapolis Projects\78704 INDOT-S I-64 ATL 00 CAD-ORD\Sheets\Bridge\No. 3 - I-64 EB over Quarry Road\1900162\_S\_PLN03.dgn

**DRAFT**  
 NOT FOR CONSTRUCTION

RECOMMENDED FOR APPROVAL	DESIGN ENGINEER	DATE
DESIGNED: PTT	DRAWN: PTT	
CHECKED: TMB	CHECKED: TMB	

**INDIANA  
 DEPARTMENT OF TRANSPORTATION**

**GENERAL PLAN**

HORIZONTAL SCALE	BRIDGE FILE	
3/32" = 1'-0"	164-120-10786	
VERTICAL SCALE	DESIGNATION	
3/32" = 1'-0"	1700207	
SURVEY BOOK	SHEETS	PLN-01
ELECTRONIC	11	of 24
CONTRACT	PROJECT	
R-42570	1900162	

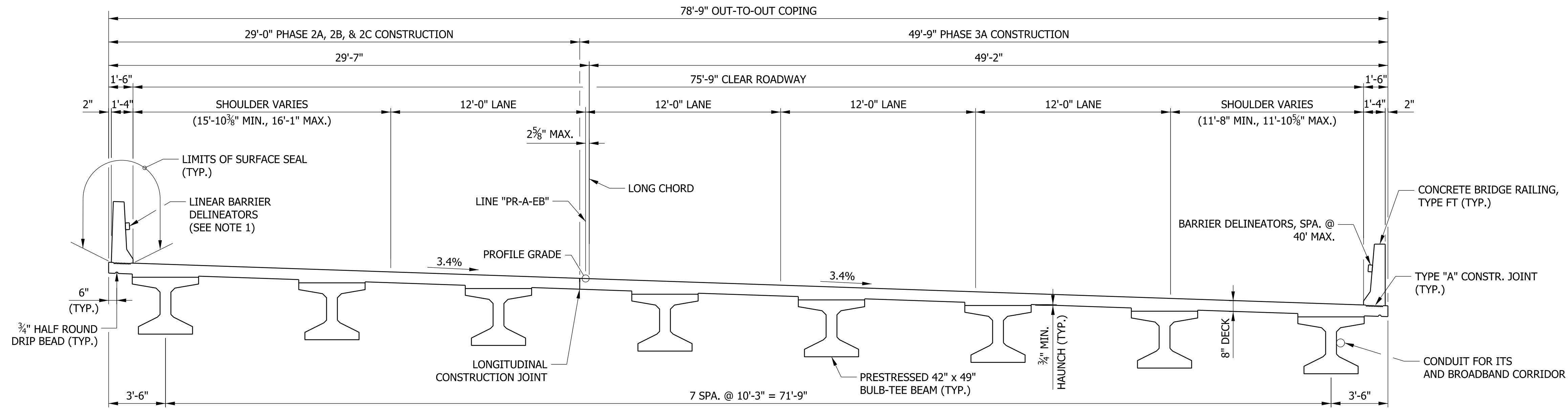

TYPICAL SECTION

**GENERAL NOTES**

ALL DIMENSIONS AND ELEVATIONS ARE IN FEET (FT), UNLESS NOTED OTHERWISE.

REINFORCING BAR COVER SHALL BE 2 1/2" IN TOP AND 1" MINIMUM IN THE BOTTOM OF THE FLOOR SLAB, AND 2" IN ALL OTHER PARTS, UNLESS OTHERWISE NOTED.

ALL EXPOSED FACES OF THE CONCRETE BRIDGE RAILINGS, CONCRETE BRIDGE RAILING TRANSITIONS, WINGS, AND END BENTS SHALL BE SURFACE SEALED. (ESTIMATED QUANTITY = 2139 SFT.)

**DESIGN DATA**

**LIVE LOAD**  
DESIGNED FOR HL-93 LOADING, IN ACCORDANCE WITH THE AASHTO LRFD BRIDGE DESIGN SPECIFICATIONS, NINTH EDITION, 2020, AND SUBSEQUENT INTERIMS.

**DEAD LOAD**  
ACTUAL WEIGHT PLUS 35 PSF (COMPOSITE) FOR FUTURE WEARING SURFACE AND 15 PSF (NON-COMPOSITE) FOR PERMANENT METAL DECK FORMS.

**FLOOR SLAB**  
DESIGNED FOR A 7 1/2" STRUCTURAL DEPTH AND A 1/2" SACRIFICIAL WEARING SURFACE.

**DESIGN STRENGTHS**  
CLASS "C" CONCRETE: f<sub>c</sub> = 4,000 PSI  
REINFORCING BARS: f<sub>y</sub> = 60,000 PSI

PRESTRESSED CONCRETE, NORMAL WEIGHT:  
f<sub>c</sub> = 8,000 PSI @ 28 DAYS  
INITIAL f<sub>c</sub> = 6,000 PSI @ RELEASE OF STRANDS  
PRESTRESSING STRANDS:  
0.6" Ø 7 WIRE L0LAX STRANDS (A<sub>s</sub> = 0.217 SQ. IN.)  
MIN. TENSILE STRENGTH = 270,000 PSI  
INITIAL PULL = 43,940 LBS. PER STRAND

**CONSTRUCTION LOADING**

THE EXTERIOR BEAMS HAVE BEEN CHECKED FOR STRENGTH, DEFLECTION, AND OVERTURNING USING CONSTRUCTION LOADS SHOWN BELOW. CANTILEVER OVERHANG BRACKETS WERE ASSUMED FOR SUPPORT OF THE DECK OVERHANG PAST THE EDGE OF EXTERIOR BEAM. THE FINISHING MACHINE WAS ASSUMED TO BE SUPPORTED 6 INCHES OUTSIDE THE VERTICAL COPING FORM. THE TOP OVERHANG BRACKETS WERE ASSUMED TO BE LOCATED 6 INCHES PAST THE EDGE OF THE VERTICAL COPING FORM. THE BOTTOM OVERHANG BRACKETS WERE ASSUMED TO BE BRACED AGAINST THE INTERSECTION OF THE BEAM BOTTOM FLANGE AND WEB.

**DECK FALSEWORK LOADS:**

DESIGNED FOR 15 PSF FOR PERMANENT METAL STAY-IN-PLACE DECK FORMS, REMOVABLE DECK FORMS, AND 2-FT. EXTERIOR WALKWAY.  
**CONSTRUCTION LIVE LOAD:**  
DESIGNED FOR 20 PSF EXTENDING 2 FT. PAST THE EDGE OF COPING AND 75 PLF VERTICAL FORCE APPLIED AT A DISTANCE OF 6 INCHES OUTSIDE THE FACE OF COPING OVER A 30-FT. LENGTH OF THE DECK CENTERED WITH THE FINISHING MACHINE.

**FINISHING-MACHINE LOAD:**

4,500 LBS DISTRIBUTED OVER 10 FT. ALONG COPING.

**WIND LOAD**

DESIGNED FOR 70 MPH HORIZONTAL WIND LOADING IN ACCORDANCE WITH AASHTO LRFD 3.8.1.

**SEISMIC DATA**

SEISMIC PERFORMANCE ZONE: X  
ACCELERATION COEFFICIENT: X.XXX  
SEISMIC SOIL PROFILE TYPE: CLASS D

**NOTE TO REVIEWER**

SEISMIC DATA WILL BE PROVIDED IN A FUTURE SUBMITTAL ONCE THE GEOTECHNICAL REPORT IS COMPLETE

**NOTE:**

1. FOR LINEAR DELINEATOR DETAILS, SEE SPECIAL PROVISIONS.

COMPOSITE PRESTRESSED CONCRETE  
BULB-TEE BEAM BRIDGE  
1 SPAN: 89'-0"  
75'-9" CLEAR ROADWAY  
SKEW: NONE  
I-64 EB OVER QUARRY ROAD  
FLOYD COUNTY

**DRAFT**  
NOT FOR CONSTRUCTION

RECOMMENDED FOR APPROVAL _____	DESIGN ENGINEER _____	DATE _____
DESIGNED: _____ PTT _____	DRAWN: _____ PTT _____	
CHECKED: _____ TMB _____	CHECKED: _____ TMB _____	

INDIANA  
DEPARTMENT OF TRANSPORTATION

GENERAL PLAN

HORIZONTAL SCALE	BRIDGE FILE	
1/4" = 1'-0"	I64-120-10786	
VERTICAL SCALE	DESIGNATION	
1/4" = 1'-0"	1700207	
SURVEY BOOK	SHEETS	PLN-02
ELECTRONIC	12	of 24
CONTRACT	PROJECT	
R-42570	1900162	

tbieman  
 12/5/2022; 9:36:09 AM  
 model: TYP-01 [Sheet]  
 file: p:\i\p\in\hmb\org\PM\Great\_Lakes\Documents\Indianapolis Projects\78704 INDOT-S I-64 ATL\00 CAD-ORD\Sheets\Bridge Bridge No. 3 - I-64 EB over Quarry Road\1900162\_5\_TYP03.dgn

PROJECT	DESIGNATION
1900162	2200015
CONTRACT	BRIDGE FILE
R-42570	I64-120-10742

STRUCTURE INFORMATION				
STRUCTURE	TYPE	SPAN AND SKEW	OVER	STATION
I64-120-10742	COMPOSITE PRESTRESSED BULB-TEE BEAM BRIDGE	1 SPAN: 89'-0" SKEW: 0°00'00"	QUARRY ROAD	☉ STA. 1212+55.38 LINE "PR-A-WB"

KIN PROJECT INFORMATION		
DESIGNATION	PROJECT DESCRIPTION	
ROAD		
1900162	Added Travel Lanes on I-64	LEAD DES.
1900366	US 150 and Old Vincennes Road (East)	
2100019	I-64 Lighting US 150 to I-64 / I-265	
BRIDGE		
1800706	Bridge Painting on US 150 EB over I-64	Str. 1
1800405	Bridge Painting on US 150 WB over I-64	Str. 2
1700207	Bridge Replacement on I-64 EB over Quarry Road	Str. 3
2200015	Bridge Replacement on I-64 WB over Quarry Road	Str. 4
1702617	Bridge Replacement on I-64 WB over I-64 Ramp to I-265 EB	Str. 5A
2200016	Bridge Replacement on I-64 EB over I-64 Ramp to I-265 EB	Str. 5B
1800721	Bridge Replacement on I-64 WB over I-265 Ramp to I-64 EB	Str. 6
2200019	Bridge Replacement on I-265 WB to I-64 EB over I-64 EB to I-265 EB	Str. 7
2200017	Bridge Replacement on I-64 EB over Captain Frank Road	Str. 8
2200018	Superstructure Replacement on I-64 WB over Captain Frank Road	Str. 9
1702614	Bridge Deck Overlay on I-64 EB & WB over Cherry Street	Str. 10
2000326 / 2000323	Bridge Deck Replacement and Widening on I-265 EB over State Street	Str. 11
2000324	Bridge Deck Overlay on I-265 WB over State Street	Str. 12
1700205	I-64 WB over SR62 / SR 64	Str. 14
1700206	I-64 EB over SR62 / SR 64	Str. 13
2000144	Bridge Deck Overlay on I-64 EB over Yenowine Lane	Str. 15
2000145	Bridge Deck Overlay on I-64 WB over Yenowine Lane	Str. 16
2002072	US 150 EB over Little Indian Creek	Str. 18
2002073	US 150 WB over Little Indian Creek	Str. 19
2200719	I-64 EB & WB over SR 62 / Spring Street	Str. 20
2200718	I-64 WB Off-Ramp to Spring over I-64 WB On-Ramp from Spring	Str. 21
DRAINAGE		
TBD	US 150 Twin Arch Pipe Liner	Str. 17
TBD	Valley View Creek (6 Small Structure and 7 Small Pipe Replacements)	
TBD	Valley View Creek CMP Liner	
TBD	UNT to Little Indian Creek CMP Liner	
TBD	Hill Brook CMP Liner	
TBD	Small Pipes CMP Liners (2)	

**NOTE TO REVIEWER**  
THE LIST OF KIN'D PROJECTS IS TENTATIVE AND SUBJECT TO CHANGE AT INDOT SEYMOUR DISTRICT'S DIRECTION. THIS LIST REPRESENTS THE CURRENT UNDERSTANDING OF THE CONTRACT PACKAGE.

**STAGE 2 PLANS**

BEGIN CONSTRUCTION  
PROJECT NO. 1900162  
STA. 1025+38.31  
LINE "PR-U-WB"

BEGIN PROJECT  
PROJECT NO. 1900162  
STA. 1180+86.02  
LINE "PR-A-EB"

BRIDGE FILE NO. I64-120-10742  
I-64 WB OVER QUARRY ROAD  
STA. 2212+55.38 LINE "PR-A-WB"

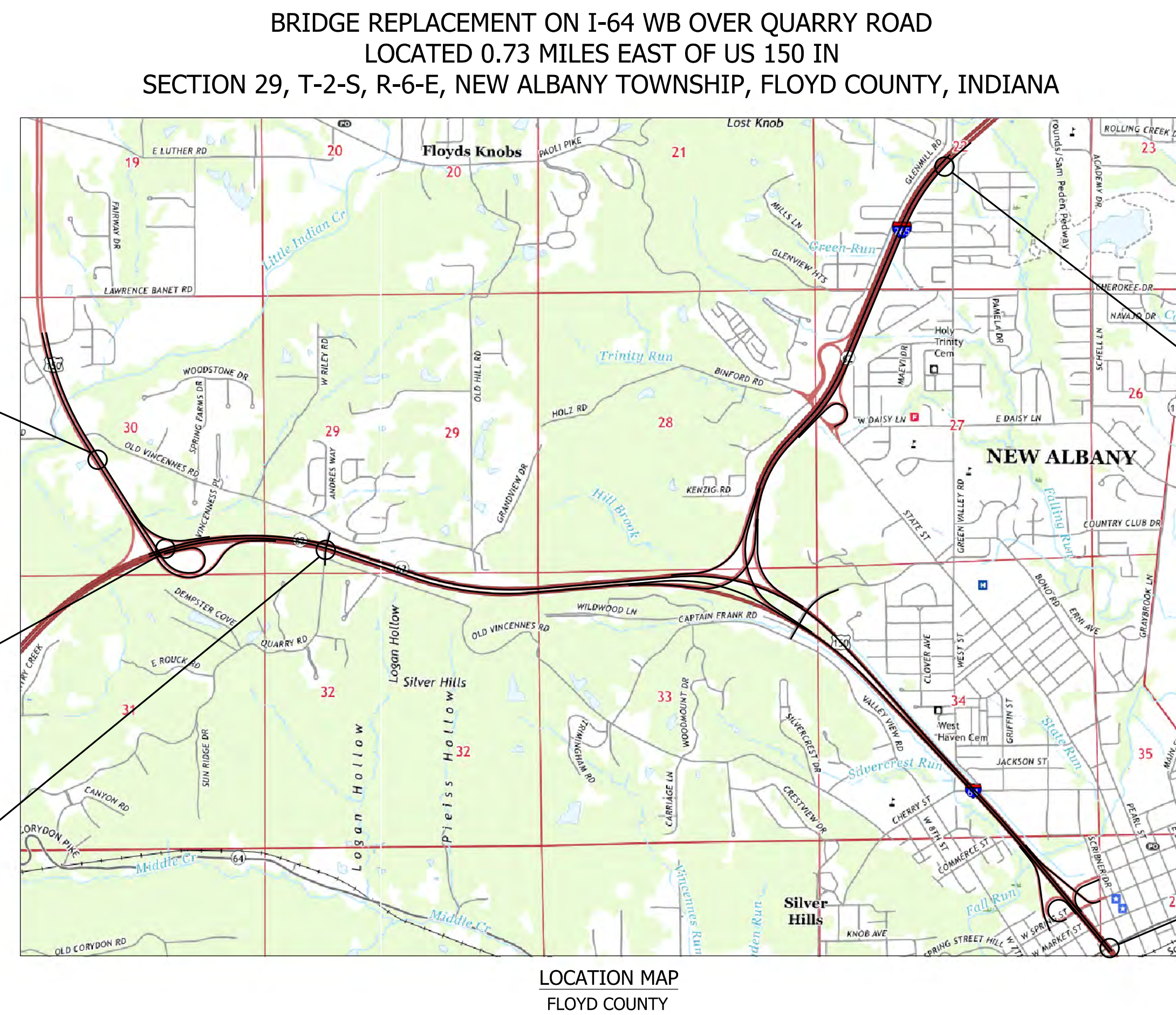

END CONSTRUCTION  
PROJECT NO. 1900162  
STA. 2077+97.42  
LINE "PR-L-EB"

**NOTE TO REVIEWER**  
PLEASE SEE CORRESPONDENCE FILE FOR DOCUMENTATION OF DESIGN DECISIONS

END PROJECT  
PROJECT NO. 1900162  
STA. 1393+50.00  
LINE "PR-A-EB"

# INDIANA DEPARTMENT OF TRANSPORTATION

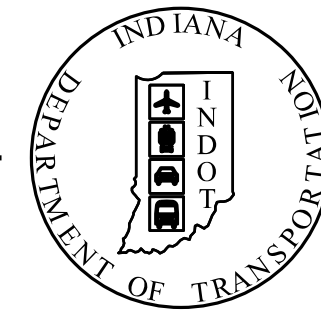

## BRIDGE PLANS

FOR SPANS OVER 20 FEET

ROUTE : I-64 WB AT: RP 119+94

PROJECT NO. 2200015 P.E.  
1900162 R/W  
2200015 CONST.

BRIDGE REPLACEMENT ON I-64 WB OVER QUARRY ROAD  
LOCATED 0.73 MILES EAST OF US 150 IN  
SECTION 29, T-2-S, R-6-E, NEW ALBANY TOWNSHIP, FLOYD COUNTY, INDIANA

TRAFFIC DATA	I-64 MAINLINE	QUARRY ROAD
A.A.D.T. (2019)	69,020 V.P.D.	1,090 V.P.D.
A.A.D.T. (2046)	94,560 V.P.D.	1,440 V.P.D.
D.H.V (2046)	8,910 V.P.H.	170 V.P.H.
DIRECTIONAL DISTRIBUTION	67%	55%
TRUCKS	10%	7%
	7% D.H.V.	10% D.H.V.

DESIGN DATA		
DESIGN SPEED	70 M.P.H.	
PROJECT DESIGN CRITERIA	4R (FREEWAY)	NO IMPROVEMENT
FUNCTIONAL CLASSIFICATION	INTERSTATE	
RURAL/URBAN	URBAN	
TERRAIN	ROLLING	
ACCESS CONTROL	FULL	



PROJECT LOCATION SHOWN BY  
FLOYD COUNTY

LATITUDE: N 38°18'14" LONGITUDE: W 85°52'44"

BRIDGE LENGTH: 0.017 MI.  
ROADWAY LENGTH: \* MI.  
TOTAL LENGTH: \* MI.  
MAX. GRADE: -2.87 %

\* SEE DES NO. 1900162

12-DIGIT HYDROLOGIC UNIT CODE: 051401040302

INDIANA DEPARTMENT OF TRANSPORTATION  
STANDARD SPECIFICATIONS DATED 2022  
TO BE USED WITH THESE PLANS



HNTB CORPORATION  
THE HNTB COMPANIES  
INFRASTRUCTURE SOLUTIONS  
111 MONUMENT CIRCLE  
SUITE 1200  
INDIANAPOLIS, IN 46204

**DRAFT**  
NOT FOR CONSTRUCTION

PLANS PREPARED BY: HNTB INDIANA, INC (317) 636-4682 PHONE NUMBER  
CERTIFIED BY: DATE  
APPROVED FOR LETTING: INDIANA DEPARTMENT OF TRANSPORTATION DATE

BRIDGE FILE	
I64-120-10742	
DESIGNATION	
2200015	
SURVEY BOOK	SHEETS TTL-01
ELECTRONIC	1 of 21
CONTRACT	PROJECT
R-42570	1900162

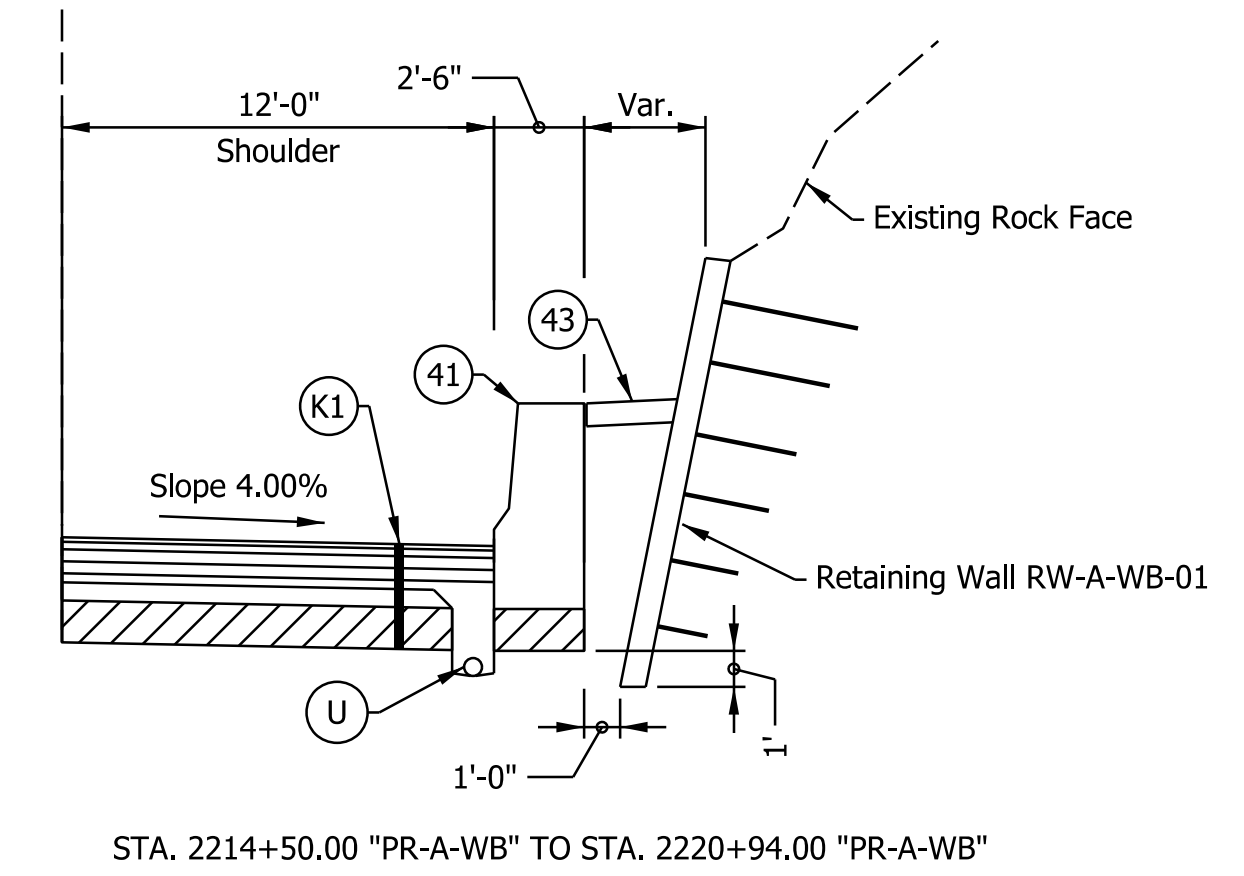
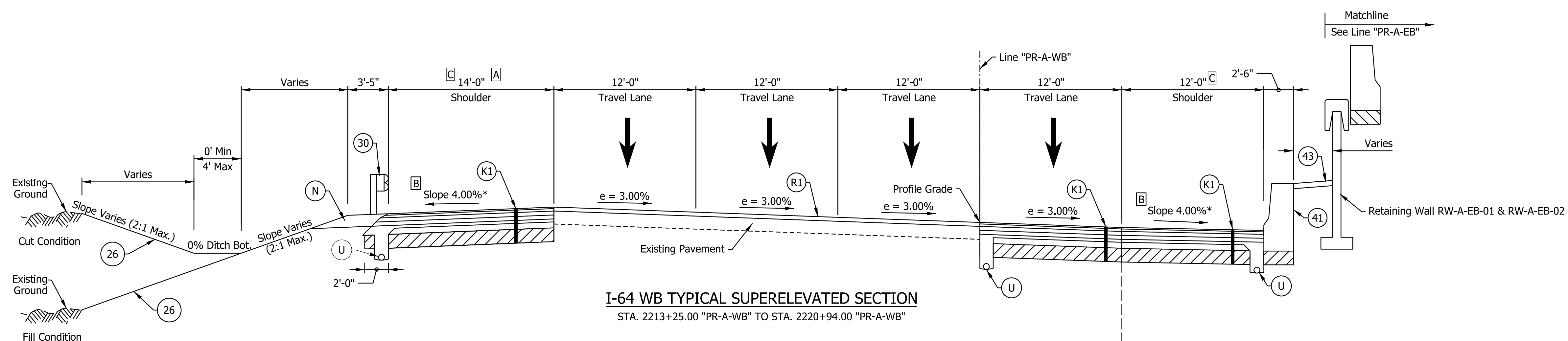
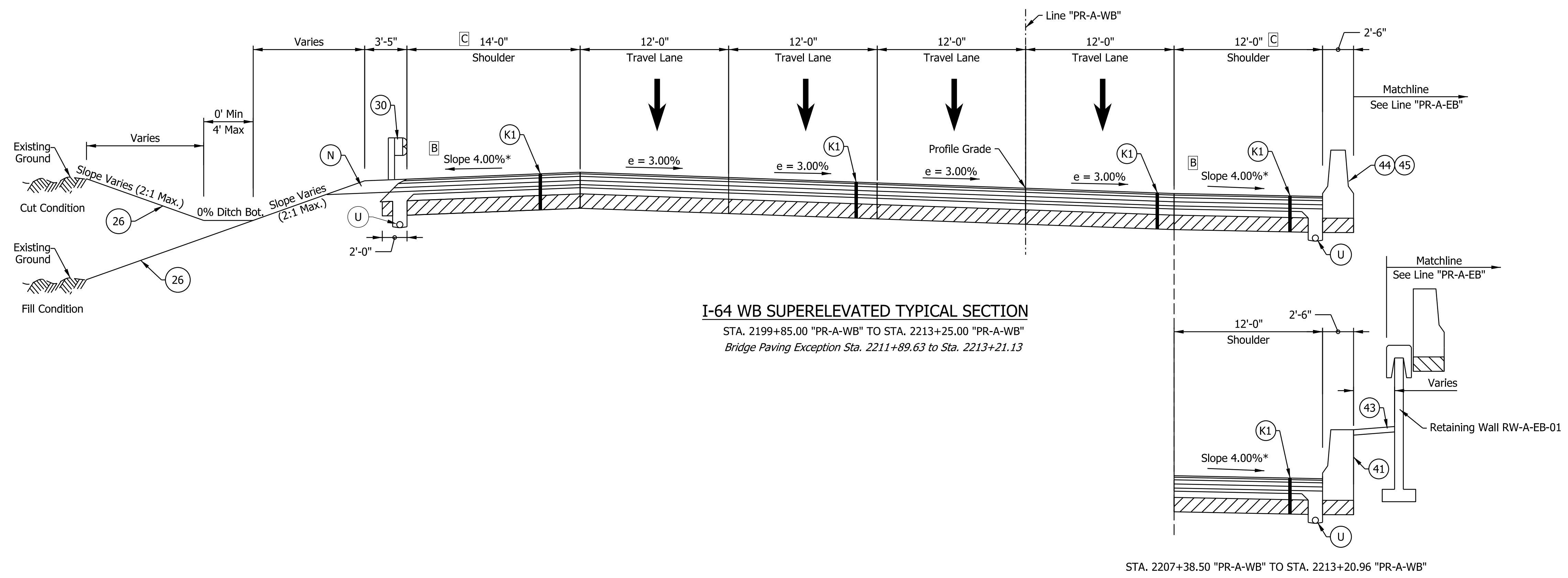

FOR INFORMATION ONLY

- Notes:
- See Sheet LGD-01 for construction legend
  - See Sheet TS-43 for Safety Edge Details
  - \* Max rollover between shoulder and travel lane not to exceed 8%.
  - A Shoulder width varies from 14'-0" at Sta. 2215+00.00 to 12'-0" at Sta. 2217+10.00. Shoulder width is 12'-0" from Sta. 2217+00 to 2220+94.00
  - B Shoulder slope to rotate to match adjacent lane slope on the bridge over Quarry Road
  - C Left shoulder width reduced to 13'-8" across the bridge over Quarry Road. Right shoulder width increased to 17'-9" across the bridge over Quarry Road

p:\preesh 12/15/2022; 8:45:49 AM model: TS-01 [Sheet] file: p:\i\p\in\hmb\org\PMGreat\_Lakes\Documents\Indianapolis Projects\78704 INDOT-S I-64 ATL 00 CAD-ORD\Sheets\Bridges\Bridge No. 4 - I-64 WB over Quarry Road\1900162\_S\_FT004.dgn

**NOTE TO REVIEWER**  
 Coordination with Geotech is in progress. Retaining Wall Details will be Refined in future Submittals

**NOTE TO REVIEWER**  
 2-foot lane extensions at the shoulders will be reviewed and implemented where applicable in a future submittal.

**DRAFT**  
 NOT FOR CONSTRUCTION

RECOMMENDED FOR APPROVAL	DESIGN ENGINEER	DATE
DESIGNED: SGM	DRAWN: CGR	
CHECKED: ADR	CHECKED: ADR	

INDIANA DEPARTMENT OF TRANSPORTATION

**I-64 WESTBOUND MAINLINE PROPOSED TYPICAL SECTIONS**

HORIZONTAL SCALE	BRIDGE FILE
3/16"=1'-0"	164-120-10742
VERTICAL SCALE	DESIGNATION
N/A	2200015
SURVEY BOOK	SHEETS
ELECTRONIC	3 of 21
CONTRACT	PROJECT
R-42570	1900162

p:\preesh 12/15/2022; 8:45:50 AM  
 model: TS-02 [Sheet]  
 file: p:\preesh\indiana\Documents\Indiana\Projects\78704 INDOT-S 1-64 ATL 00 CAD-ORD\Sheets\Bridges\Bridges\No. 4 - 1-64 WB over Quarry Road\1900162\_S\_FT004.dgn

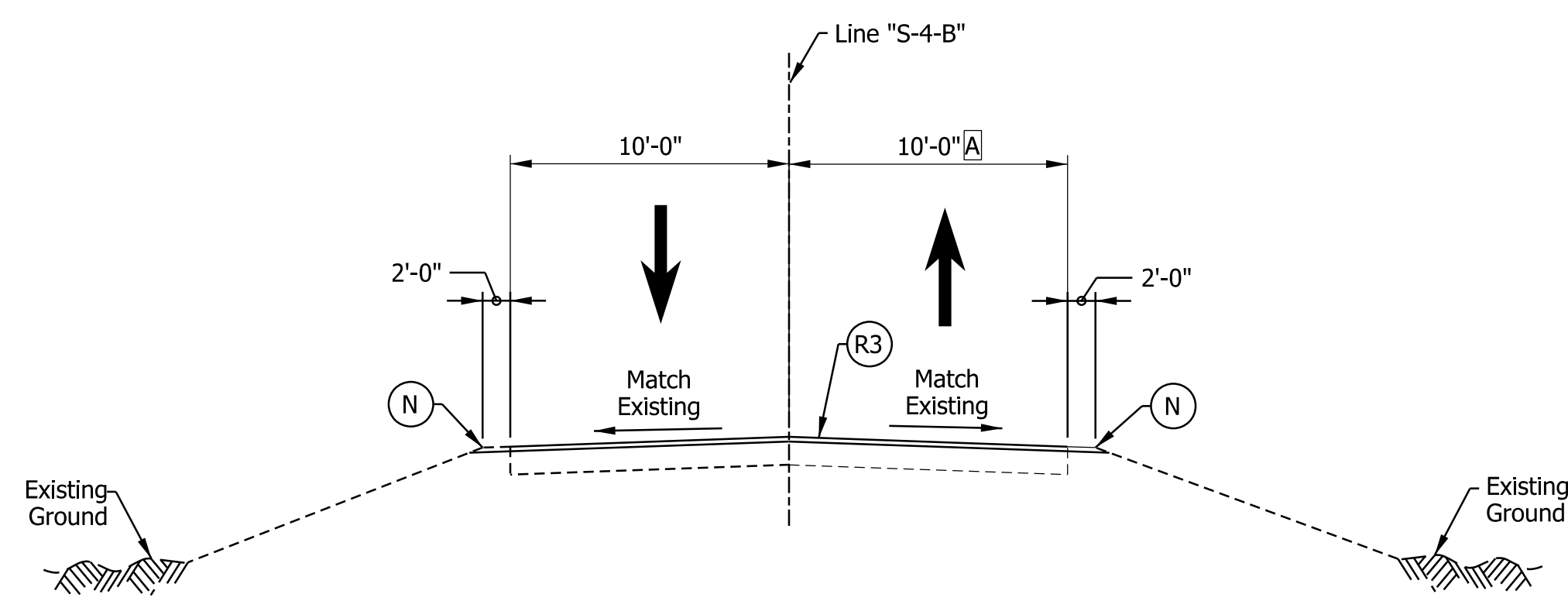

**Captain Frank Road Typical Section**  
 STA. 48+50.00 "S-4-B" TO STA. 54+00.00 "S-4-B"

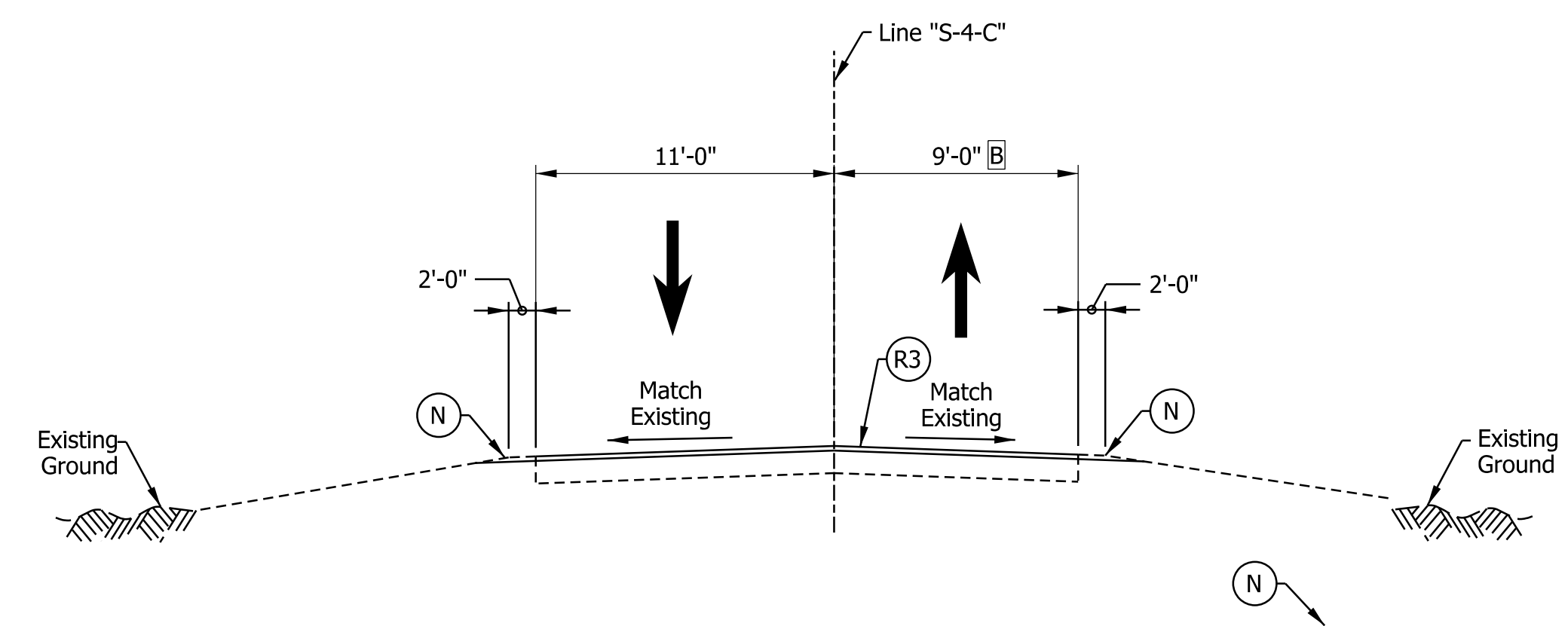

**Quarry Road Typical Section**  
 STA. 47+31.00 "S-4-C" TO STA. 51+70.00 "S-4-C"

FOR INFORMATION ONLY

**Notes:**

See Sheet LGD-01 for construction legend  
 See Sheet TS-43 for Safety Edge Details

- Ⓐ Northbound Travel Lane is 10'-0" from Sta. 48+50 "S-4-B" to Sta. 52+50 "S-4-B"  
 Northbound Travel Lane Varies from 10'-0" to 11'-6" from Sta. 52+50 "S-4-B" to Sta. 54+00 "S-4-B"
- Ⓑ Northbound Travel Lane Varies from 9'-0" to 14'-6" from Sta. 51+25 "S-4-C" to Sta. 51+70 "S-4-C"

**DRAFT**  
 NOT FOR CONSTRUCTION

RECOMMENDED FOR APPROVAL _____	DESIGN ENGINEER _____	DATE _____
DESIGNED: _____ JKH _____	DRAWN: _____ JKH _____	
CHECKED: _____ ADR _____	CHECKED: _____ ADR _____	

**INDIANA**  
**DEPARTMENT OF TRANSPORTATION**  
  
**QUARRY ROAD / CAPTAIN FRANK ROAD**  
**PROPOSED TYPICAL SECTIONS**

HORIZONTAL SCALE	BRIDGE FILE
3/16"=1'-0"	164-120-10742
VERTICAL SCALE	DESIGNATION
N/A	2200015
SURVEY BOOK	SHEETS TS-42
ELECTRONIC	4 of 21
CONTRACT	PROJECT
R-42570	1900162

preesh  
12/5/2022; 8:46:23 AM  
model: PP-01 [Sheet]  
file: p:\i\p\in\hmb\org\PM\Great\_Lakes\Documents\Indianapolis Projects\78704 INDOT-S I-64 ATL 00 CAD-ORD\Sheets\Bridge\Bridge No. 4 - I-64 WB over Quarry Road\1900162\_S\_F1004.dgn

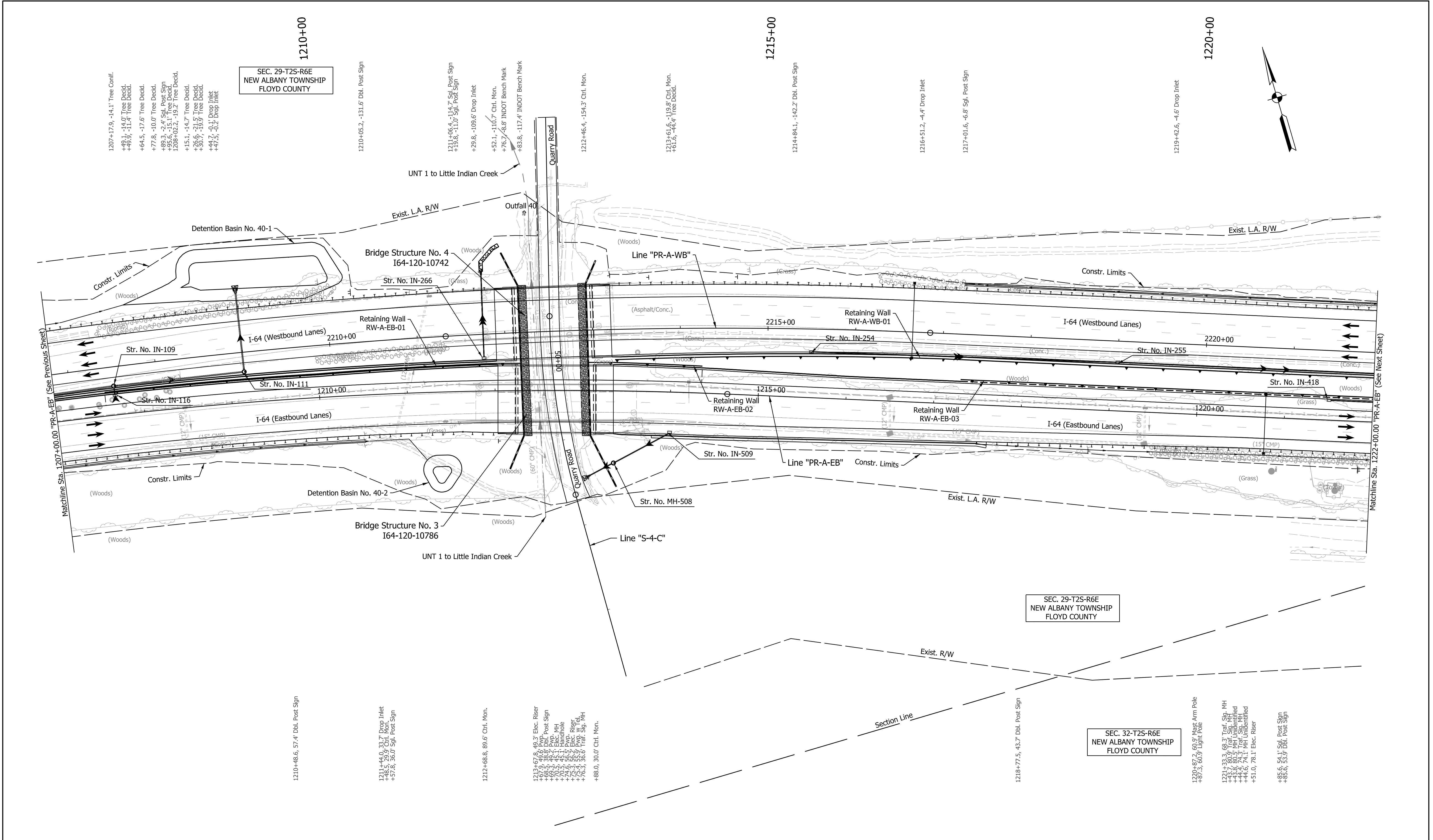

SEC. 29-T2S-R6E  
NEW ALBANY TOWNSHIP  
FLOYD COUNTY

SEC. 29-T2S-R6E  
NEW ALBANY TOWNSHIP  
FLOYD COUNTY

SEC. 32-T2S-R6E  
NEW ALBANY TOWNSHIP  
FLOYD COUNTY

Note:  
For Geometric information see Geometric Layout Sheets  
GEO-01 to GEO-13.

FOR INFORMATION ONLY

**DRAFT**  
NOT FOR CONSTRUCTION

RECOMMENDED FOR APPROVAL	DESIGN ENGINEER	DATE
DESIGNED: SGM	DRAWN: RJS	
CHECKED: KRC	CHECKED: KRC	

INDIANA  
DEPARTMENT OF TRANSPORTATION

PLAN SHEET  
LINE "PR-A-EB" STA. 1207+00 TO STA. 1222+00  
LINE "PR-A-WB" - STA. 2207+00 TO STA. 2222+00

HORIZONTAL SCALE	BRIDGE FILE	
1"=50'	I64-120-10742	
VERTICAL SCALE	DESIGNATION	
N/A	2200015	
SURVEY BOOK	SHEETS	PLN-03
ELECTRONIC	5	of 21
CONTRACT	PROJECT	
R-42570	1900162	



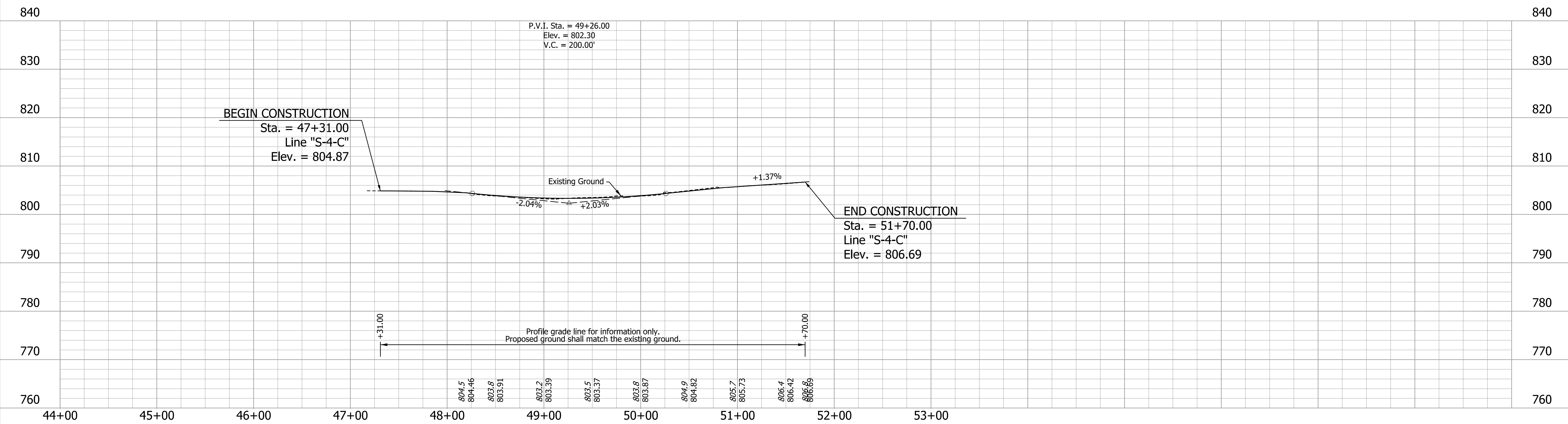
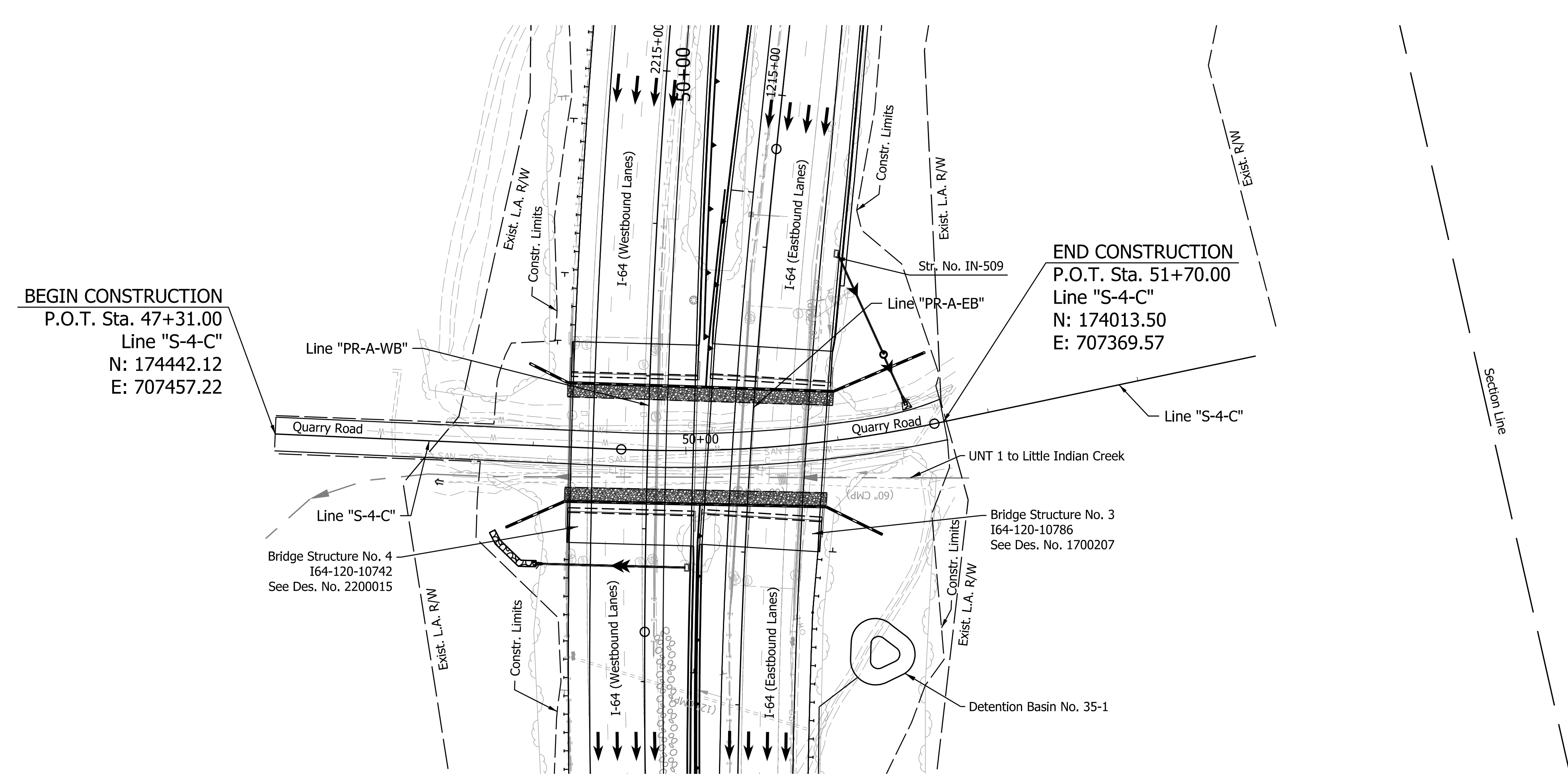
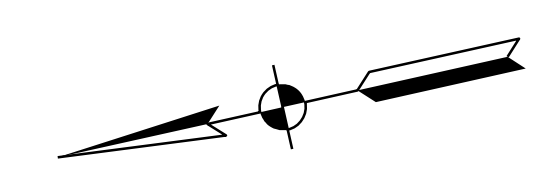

FOR INFORMATION ONLY

**DRAFT**  
NOT FOR CONSTRUCTION

RECOMMENDED FOR APPROVAL	DESIGN ENGINEER	DATE
DESIGNED: SGM	DRAWN: RJS	
CHECKED: KRC	CHECKED: KRC	

INDIANA  
DEPARTMENT OF TRANSPORTATION

PLAN SHEET  
LINE "S-4-C"  
STA. 47+31 TO STA. 51+70

HORIZONTAL SCALE 1" = 50'	BRIDGE FILE I64-120-10742
VERTICAL SCALE 1" = 10'	DESIGNATION 2200015
SURVEY BOOK ELECTRONIC	SHEETS 7 of 21
CONTRACT R-42570	PROJECT 1900162

preesh 12/5/2022 8:46:27 AM  
 model: PP-03 [Sheet]  
 file: p:\i\p\in\hmb\org\PMGreat\_Lakes\Documents\Indianapolis Projects\78704 INDOT-S I-64 ATL 00 CAD-ORD\Sheets\Bridges\Bridg No. 4 - I-64 WB over Quarry Road\1900162\_S\_F1004.dgn

p:\preesh\12/15/2022\10:22:43 AM\mdeh\PIN-01 [Sheet].dwg  
 file: p:\preesh\12/15/2022\10:22:43 AM\mdeh\PIN-01 [Sheet].dwg

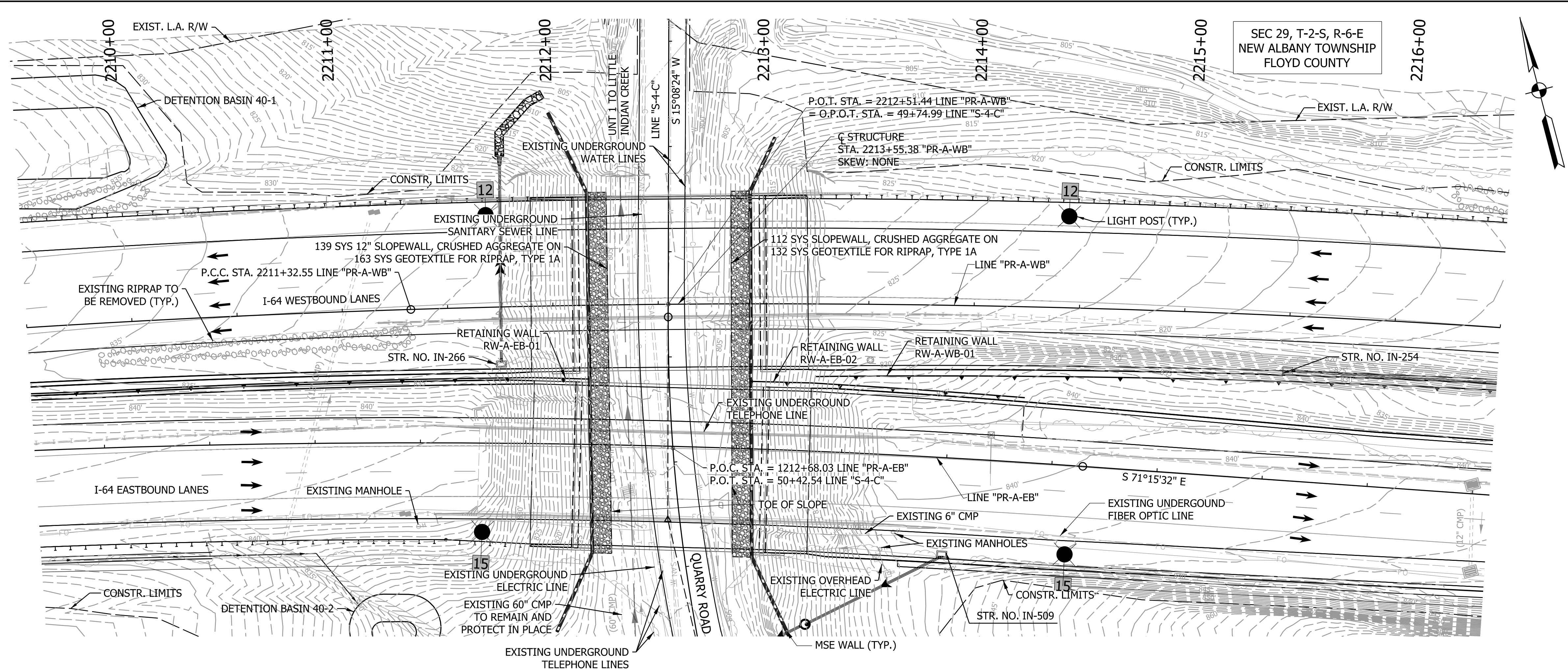

SEC 29, T-2-S, R-6-E  
 NEW ALBANY TOWNSHIP  
 FLOYD COUNTY

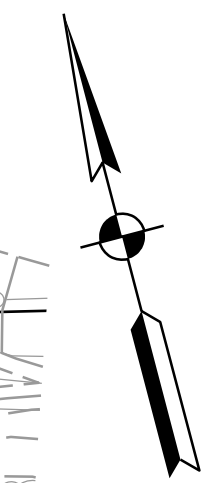

**EXISTING STRUCTURE**  
 EXISTING STRUCTURE (I64-120-04984 CWBL) IS A THREE-SPAN (49'-6 1/2", 50'-1", 49'-6 1/2") PRESTRESSED CONCRETE COMPOSITE I-BEAM BRIDGE WITH A 56'-2" CLEAR ROADWAY. STRUCTURE IS TO BE REMOVED. EXISTING BRIDGE PLANS ON FILE WITH THE INDIANA DEPARTMENT OF TRANSPORTATION AS FILE NO. I64-120-04984, A, B, & CWBL.

**EARTHWORK TABULATION**  
 FOR EARTHWORK SUMMARY, SEE ROAD PLANS DES. NO. 1900162

**NOTE TO REVIEWER**  
 UTILITY COORDINATION IS ONGOING AND ONCE FINALIZED THE EXISTING UTILITIES WILL BE IDENTIFIED AS "TO REMAIN & PROTECT-IN-PLACE", "RELOCATED", OR "ABANDONED" AS REQUIRED.

**HORIZONTAL CURVE DATA FOR LINE "PR-A-WB"**

CURVE 1	CURVE 2
P.I. 2194+92.44 LINE "PR-A-WB"	P.I. 2214+08.96 LINE "PR-A-WB"
$\Delta = 33^{\circ}07'08"$ RT	$\Delta = 05^{\circ}54'54"$ RT
D = 0°58'51.60"	D = 01°04'15.41"
R = 5843.17'	R = 5350.01'
T = 1737.40'	T = 276.41'
L = 3377.51'	L = 552.08'
E = 252.83'	E = 7.14'
SE = 3.00%	SE = 3.00%

**HORIZONTAL CURVE DATA FOR LINE "S-4-C"**

P.I. 50+61.37 LINE "S-4-C"
$\Delta = 14^{\circ}25'54.66"$ LT.
D = 07°00'00.00"
R = 818.51'
T = 103.63'
L = 206.17'
E = 6.53'
SE = N.C.

**NOTES:**

- FOR REFERENCE TIES AND BENCHMARKS, SEE ROAD PLANS DES. NO. 1900162.
- FOR DITCH GRADES & GUARDRAIL LIMITS, SEE PLAN & PROFILE SHEET OF ROAD PLANS DES. NO. 1900162.
- FOR RETAINING WALL RW-A-EB-01, RW-A-EB-02, AND RW-A-WB-01 DETAILS, SEE ROAD PLANS DES. NO. 1900162.
- FOR EXISTING AND PROPOSED UTILITIES, DRAINAGE, LIGHTING, SIGNING, AND ITS, SEE ROAD PLANS DES. NO. 1900162.

**COMPOSITE PRESTRESSED CONCRETE BULB-TEE BEAM BRIDGE**  
 1 SPAN: 89'-0"  
 79'-8" CLEAR ROADWAY  
 SKEW: NONE  
 I-64 WB OVER QUARRY ROAD  
 FLOYD COUNTY

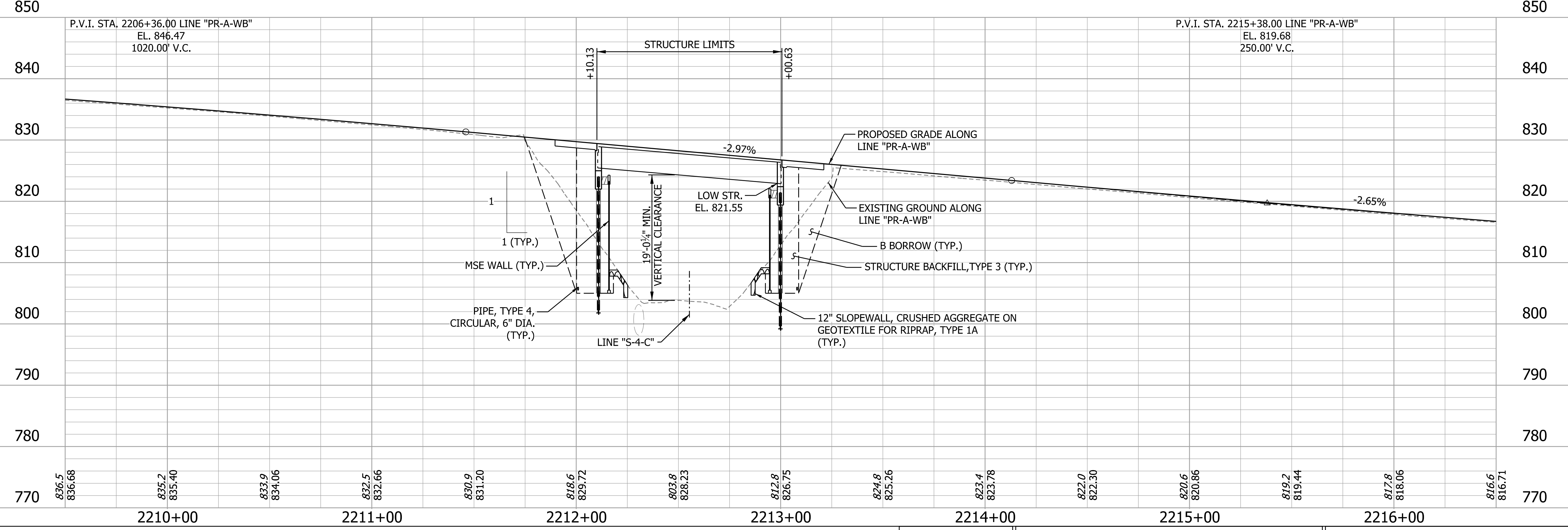

**DRAFT**  
 NOT FOR CONSTRUCTION

RECOMMENDED FOR APPROVAL	DESIGN ENGINEER	DATE
DESIGNED: PTT	DRAWN: PTT	
CHECKED: TMB	CHECKED: TMB	

INDIANA DEPARTMENT OF TRANSPORTATION  
 LAYOUT - LINE "PR-A-WB"

HORIZONTAL SCALE	BRIDGE FILE	
1" = 30'	I64-120-10742	
VERTICAL SCALE	DESIGNATION	
1" = 10'	2200015	
SURVEY BOOK	SHEETS	LAY-01
ELECTRONIC	10	of 21
CONTRACT	PROJECT	
R-42570	1900162	

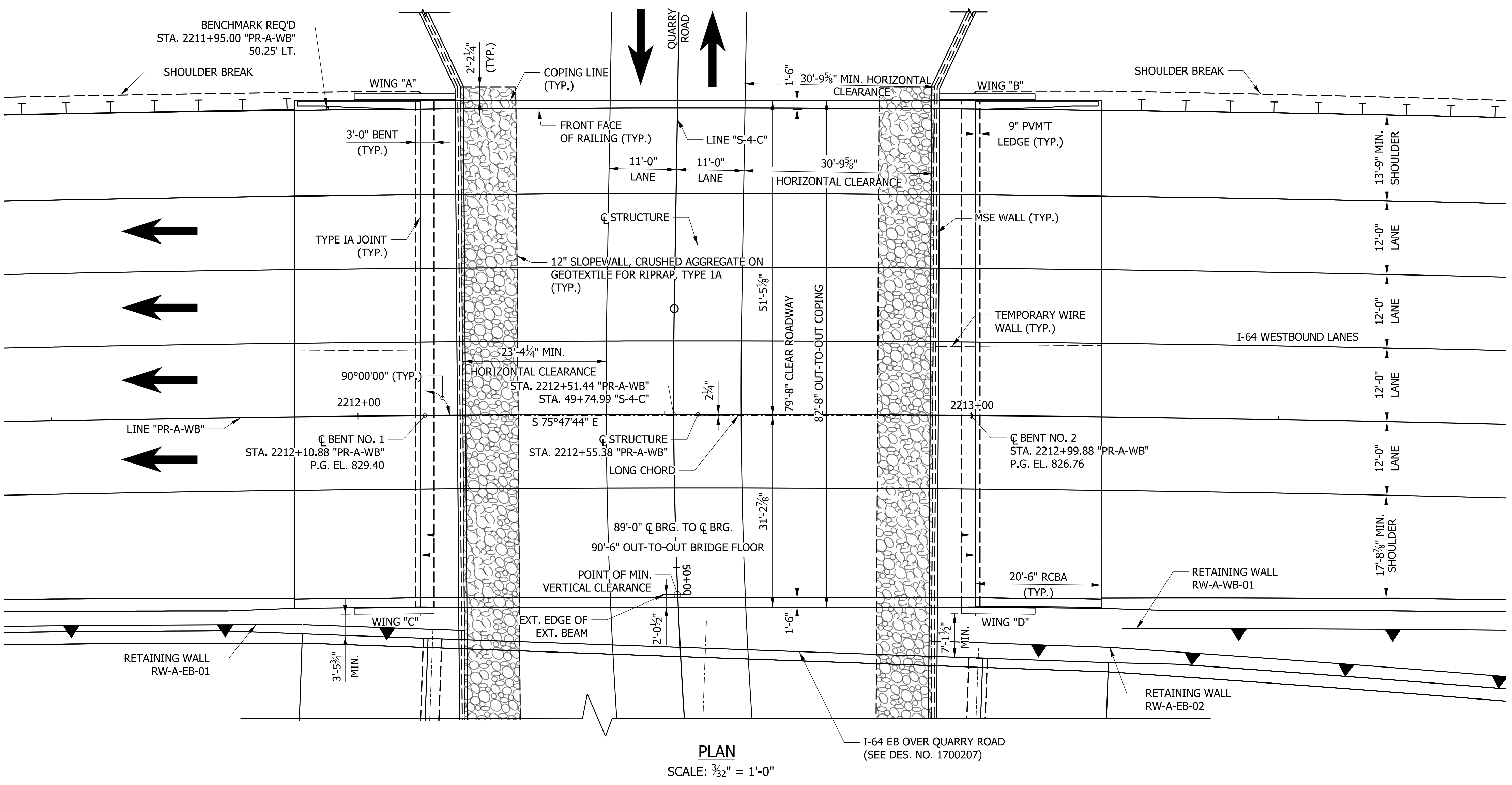
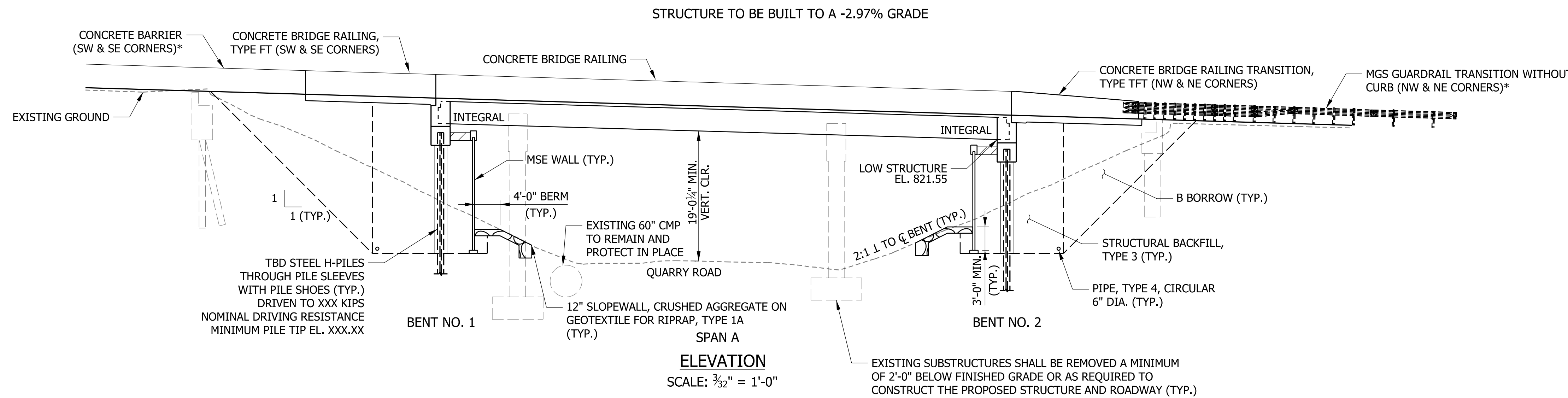

**NOTE TO REVIEWER**

THE GEOTECHNICAL INVESTIGATION IS CURRENTLY UNDERWAY AND PILE AND FOUNDATION INFORMATION WILL BE ADDED AT A FUTURE SUBMITTAL.

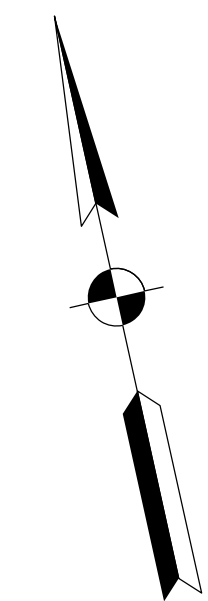

- LEGEND:**
- NW DENOTES NORTHWEST
  - SW DENOTES SOUTHWEST
  - NE DENOTES NORTHEAST
  - SE DENOTES SOUTHEAST
  - \* ROADWAY ITEMS UNDER LEAD DES 1900162
- NOTES:**
1. FOR RETAINING WALL DETAILS, SEE I-64 EB OVER QUARRY ROAD (DES. NO. 1700207).

**COMPOSITE PRESTRESSED CONCRETE BULB-TEE BEAM BRIDGE**  
**1 SPAN: 89'-0"**  
**79'-8" CLEAR ROADWAY**  
**SKEW: NONE**  
**I-64 WB OVER QUARRY ROAD**  
**FLOYD COUNTY**

p:\preesh 12/5/2022; 8:46:07 AM model: PLN-01 [Sheet] file: p:\preesh\lakes\indianapolis\projects\78704 INDOT-S I-64 ATL\00 CAD-ORD\Sheets\Bridges\Bridges\No. 4 - I-64 WB over Quarry Road\1900162\_S\_PLN04.dgn

**DRAFT**  
 NOT FOR CONSTRUCTION

RECOMMENDED FOR APPROVAL _____	DESIGN ENGINEER _____	DATE _____
DESIGNED: _____ PTT _____	DRAWN: _____ PTT _____	
CHECKED: _____ TMB _____	CHECKED: _____ TMB _____	

INDIANA DEPARTMENT OF TRANSPORTATION

GENERAL PLAN

HORIZONTAL SCALE	BRIDGE FILE
3/32" = 1'-0"	164-120-10742
VERTICAL SCALE	DESIGNATION
3/32" = 1'-0"	2200015
SURVEY BOOK	SHEETS PLN-01
ELECTRONIC	11 of 21
CONTRACT	PROJECT
R-42570	1900162

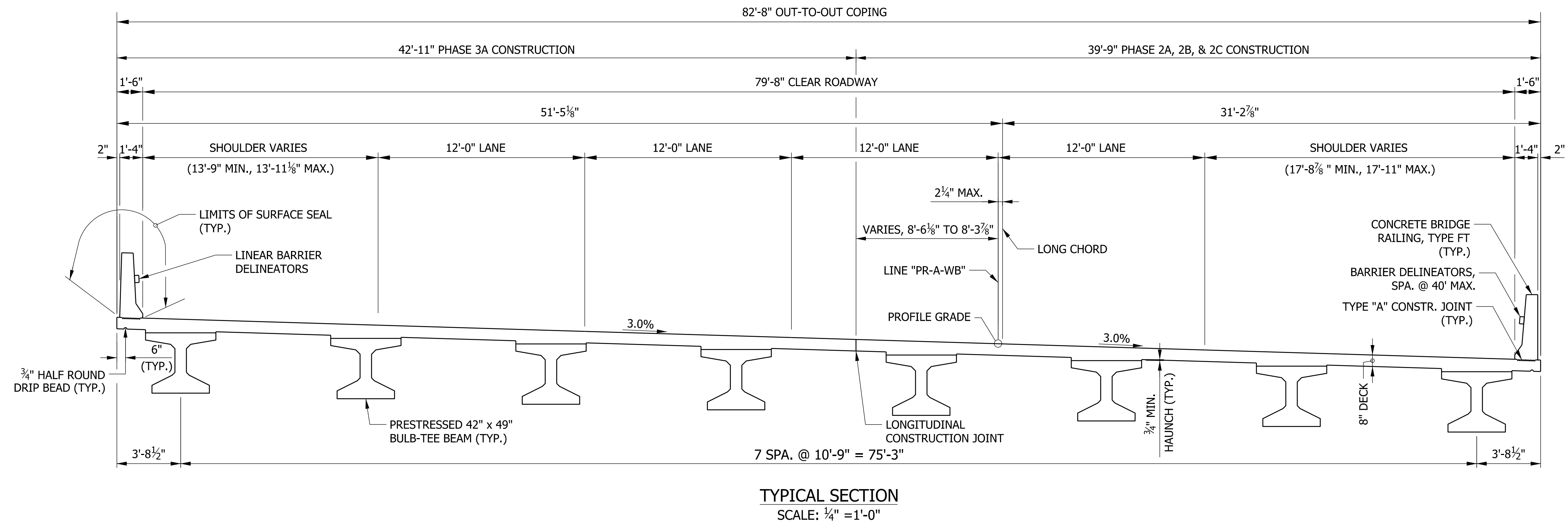

TYPICAL SECTION  
SCALE: 1/4" = 1'-0"

**GENERAL NOTES**

ALL DIMENSIONS AND ELEVATIONS ARE IN FEET (FT), UNLESS NOTED OTHERWISE.  
REINFORCING BAR COVER SHALL BE 2 1/2" IN TOP AND 1" IN THE BOTTOM OF THE FLOOR SLAB, AND 2" IN ALL OTHER PARTS, UNLESS OTHERWISE NOTED.  
ALL EXPOSED FACES OF THE CONCRETE BRIDGE RAILINGS, CONCRETE BRIDGE RAILING TRANSITIONS, WINGS, AND END BENTS SHALL BE SURFACE SEALED. (ESTIMATED QUANTITY = 2089 SF.)

**DESIGN DATA**

**LIVE LOAD**  
DESIGNED FOR HL-93 LOADING, IN ACCORDANCE WITH THE AASHTO LRFD BRIDGE DESIGN SPECIFICATIONS, NINTH EDITION, 2020, AND SUBSEQUENT INTERIMS.

**DEAD LOAD**  
ACTUAL WEIGHT PLUS 35 PSF (COMPOSITE) FOR FUTURE WEARING SURFACE AND 15 PSF (NON-COMPOSITE) FOR PERMANENT METAL DECK FORMS.

**FLOOR SLAB**  
DESIGNED FOR A 7 1/2" STRUCTURAL DEPTH AND A 1/2" SACRIFICIAL WEARING SURFACE.

**DESIGN STRENGTHS**  
CLASS "C" CONCRETE: f<sub>c</sub> = 4,000 PSI  
REINFORCING BARS: f<sub>y</sub> = 60,000 PSI  
  
PRESTRESSED CONCRETE, NORMAL WEIGHT:  
f<sub>c</sub> = 8,000 PSI @ 28 DAYS  
INITIAL f<sub>c</sub> = 6,000 PSI @ RELEASE OF STRANDS  
PRESTRESSING STRANDS:  
0.6" Ø 7 WIRE LOLAX STRANDS (A<sub>s</sub> = 0.217 SQ. IN.)  
MIN. TENSILE STRENGTH = 270,000 PSI  
INITIAL PULL = 43,940 LBS. PER STRAND

**CONSTRUCTION LOADING**  
THE EXTERIOR BEAMS HAVE BEEN CHECKED FOR STRENGTH, DEFLECTION, AND OVERTURNING USING CONSTRUCTION LOADS SHOWN BELOW. CANTILEVER OVERHANG BRACKETS WERE ASSUMED FOR SUPPORT OF THE DECK OVERHANG PAST THE EDGE OF EXTERIOR BEAM. THE FINISHING MACHINE WAS ASSUMED TO BE SUPPORTED 6 INCHES OUTSIDE THE VERTICAL COPING FORM. THE TOP OVERHANG BRACKETS WERE ASSUMED TO BE LOCATED 6 INCHES PAST THE EDGE OF THE VERTICAL COPING FORM. THE BOTTOM OVERHANG BRACKETS WERE ASSUMED TO BE BRACED AGAINST THE INTERSECTION OF THE BEAM BOTTOM FLANGE AND WEB.

**DECK FALSEWORK LOADS**  
DESIGNED FOR 15 PSF FOR PERMANENT METAL STAY-IN-PLACE DECK FORMS, REMOVABLE DECK FORMS, AND 2-FT. EXTERIOR WALKWAY.

**CONSTRUCTION LIVE LOAD**  
DESIGNED FOR 20 PSF EXTENDING 2 FT. PAST THE EDGE OF COPING AND 75 PLF VERTICAL FORCE APPLIED AT A DISTANCE OF 6 INCHES OUTSIDE THE FACE OF COPING OVER A 30-FT. LENGTH OF THE DECK CENTERED WITH THE FINISHING MACHINE.

**FINISHING-MACHINE LOAD**  
4,500 LBS DISTRIBUTED OVER 10 FT. ALONG COPING.

**WIND LOAD**  
DESIGNED FOR 70 MPH HORIZONTAL WIND LOADING IN ACCORDANCE WITH AASHTO LRFD 3.8.1.

**SEISMIC DATA**  
SEISMIC PERFORMANCE ZONE: X  
ACCELERATION COEFFICIENT: .X.XXX  
SEISMIC SOIL PROFILE TYPE: CLASS D

**NOTE TO REVIEWER**  
SEISMIC DATA WILL BE PROVIDED IN A FUTURE SUBMITTAL ONCE THE GEOTECHNICAL REPORT IS COMPLETE.

**NOTES:**  
1. FOR LINEAR DELINEATOR DETAILS, SEE SPECIAL PROVISIONS.

COMPOSITE PRESTRESSED CONCRETE  
BULB-TEE BEAM BRIDGE  
1 SPAN: 89'-0"  
79'-8" CLEAR ROADWAY  
SKEW: 0°  
I-64 WB OVER QUARRY ROAD  
FLOYD COUNTY

bheneman 12/15/2022; 8:48:22 AM model: PLN-02 [Sheet] file: pw:/pwr-inl.mdb.org/PlnGreat\_Lakes/Documents/Indianapolis Projects/78704 INDOT-5 I-64 ATL/00 CAD-ORD/Sheets/Bridge/Bridge No. 4 - I-64 WB over Quarry Road/1900162\_S\_T1P04.dgn

**DRAFT**  
NOT FOR CONSTRUCTION

RECOMMENDED FOR APPROVAL _____	DESIGN ENGINEER _____	DATE _____
DESIGNED: _____ PTT _____	DRAWN: _____ PTT _____	
CHECKED: _____ TMB _____	CHECKED: _____ TMB _____	

INDIANA  
DEPARTMENT OF TRANSPORTATION

GENERAL PLAN

HORIZONTAL SCALE		BRIDGE FILE	
AS NOTED		164-120-10742	
VERTICAL SCALE		DESIGNATION	
AS NOTED		2200015	
SURVEY BOOK	SHEETS	PLN-02	
ELECTRONIC	12	of	21
CONTRACT		PROJECT	
R-42570		1900162	

PROJECT	DESIGNATION
1900162	1702617
CONTRACT	BRIDGE FILE
R-42570	I64-121-10787

STRUCTURE INFORMATION				
STRUCTURE	TYPE	SPAN AND SKEW	OVER	STATION
I64-121-10787	CONTINUOUS COMPOSITE PRESTRESSED CONCRETE BULB-TEE BEAM BRIDGE	3 SPANS: 90'-0", 132'-0", 90'-0" SKEW: 45°00'00" RT.	I-64 EB RAMP TO I-265 EB	± STA. 2292+17.92 "PR-A-WB"

KIN PROJECT INFORMATION		
DESIGNATION	PROJECT DESCRIPTION	
ROAD		
1900162	Added Travel Lanes on I-64	LEAD DES.
1900366	US 150 and Old Vincennes Road (East)	
2100019	I-64 Lighting US 150 to I-64 / I-265	
BRIDGE		
1800706	Bridge Painting on US 150 EB over I-64	Str. 1
1800405	Bridge Painting on US 150 WB over I-64	Str. 2
1700207	Bridge Replacement on I-64 EB over Quarry Road	Str. 3
2200015	Bridge Replacement on I-64 WB over Quarry Road	Str. 4
1702617	Bridge Replacement on I-64 WB over I-64 Ramp to I-265 EB	Str. 5A
2200016	Bridge Replacement on I-64 EB over I-64 Ramp to I-265 EB	Str. 5B
1800721	Bridge Replacement on I-64 WB over I-265 Ramp to I-64 EB	Str. 6
2200019	Bridge Replacement on I-265 WB to I-64 EB over I-64 EB to I-265 EB	Str. 7
2200017	Superstructure Replacement on I-64 EB over Captain Frank Road	Str. 8
2200018	Superstructure Replacement on I-64 WB over Captain Frank Road	Str. 9
1702614	Bridge Deck Overlay on I-64 EB & WB over Cherry Street	Str. 10
2000326 / 2000323	Bridge Deck Replacement and Widening on I-265 EB over State Street	Str. 11
2000324	Bridge Deck Overlay on I-265 WB over State Street	Str. 12
1700205	I-64 WB over SR62 / SR 64	Str. 14
1700206	I-64 EB over SR62 / SR 64	Str. 13
2000144	Bridge Deck Overlay on I-64 EB over Yenowine Lane	Str. 15
2000145	Bridge Deck Overlay on I-64 WB over Yenowine Lane	Str. 16
2002072	US 150 EB over Little Indian Creek	Str. 18
2002073	US 150 WB over Little Indian Creek	Str. 19
2200719	I-64 EB & WB over SR 62 / Spring Street	Str. 20
2200178	I-64 WB Off-Ramp to Spring over I-64 WB On-Ramp from Spring	Str. 21
DRAINAGE		
TBD	US 150 Twin Arch Pipe Liner	Str. 17
TBD	Valley View Creek (6 Small Structure and 7 Small Pipe Replacements)	
TBD	Valley View Creek CMP Liner	
TBD	UNT to Little Indian Creek CMP Liner	
TBD	Hill Brook CMP Liner	
TBD	Small Pipes CMP Liners (2)	

# INDIANA DEPARTMENT OF TRANSPORTATION

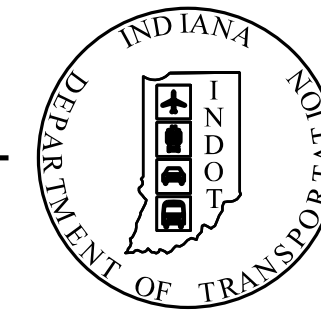

## BRIDGE PLANS

FOR SPANS OVER 20 FEET

ROUTE : I-64 WB AT: RP 121+32.40

PROJECT NO. 1702617 P.E.  
1900162 R/W  
1702617 CONST.

**NOTE TO REVIEWER**  
PLEASE SEE CORRESPONDENCE FILE FOR DOCUMENTATION OF DESIGN DECISIONS

BRIDGE REPLACEMENT ON I-64 WB OVER I-64 EB TO I-265 EB RAMP  
LOCATED 2.11 MILES EAST OF US 150 IN  
SECTION 33, T-2-S, R-6-E, NEW ALBANY TOWNSHIP, FLOYD COUNTY, INDIANA

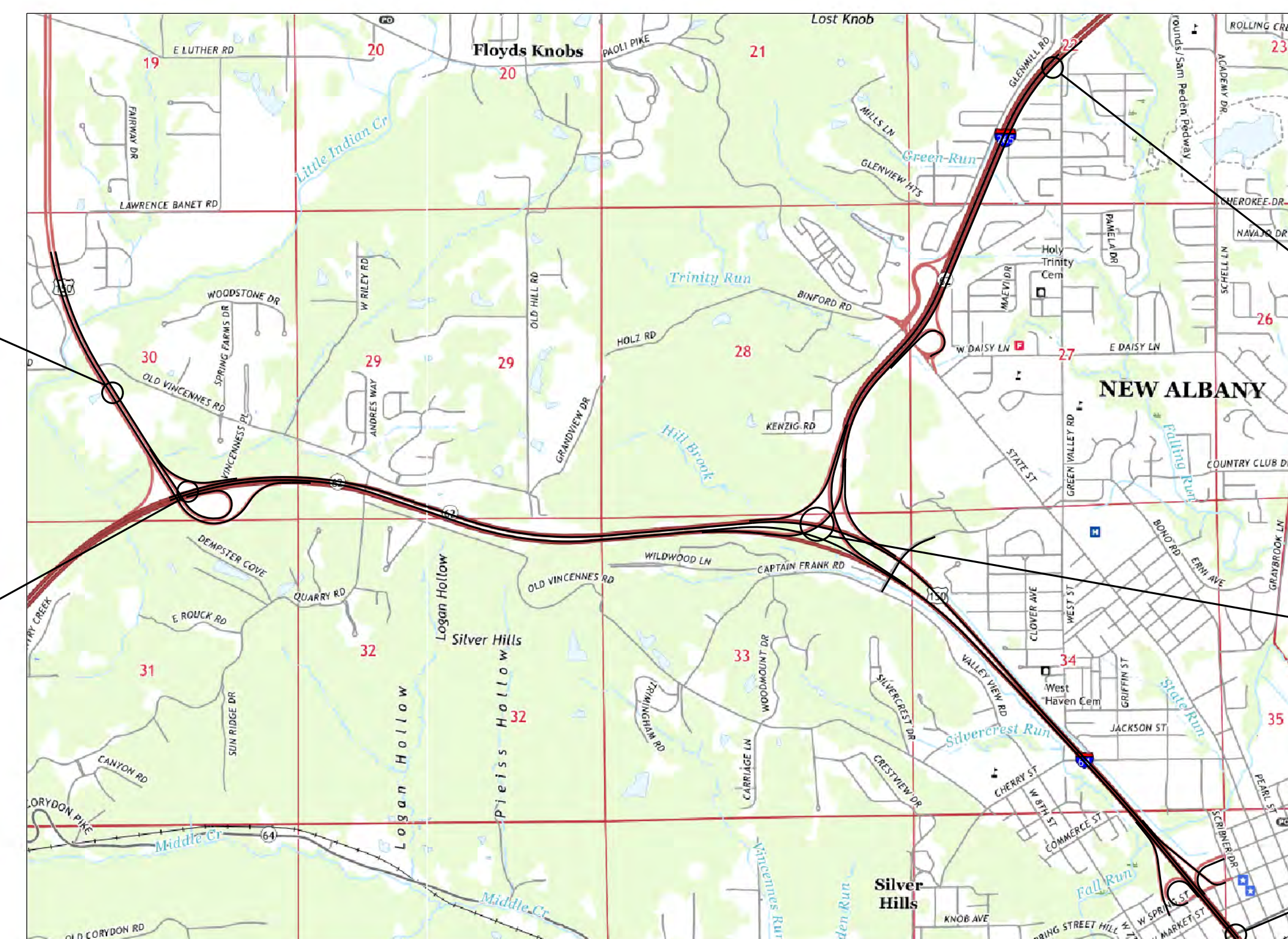

LOCATION MAP  
FLOYD COUNTY

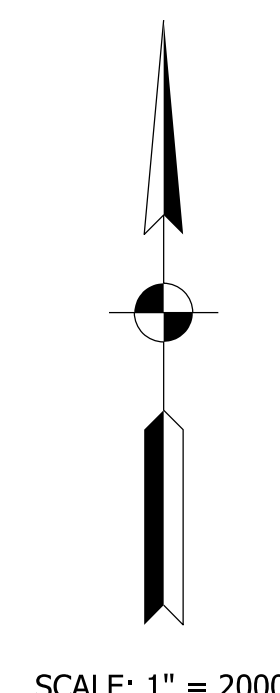

SCALE: 1" = 2000'

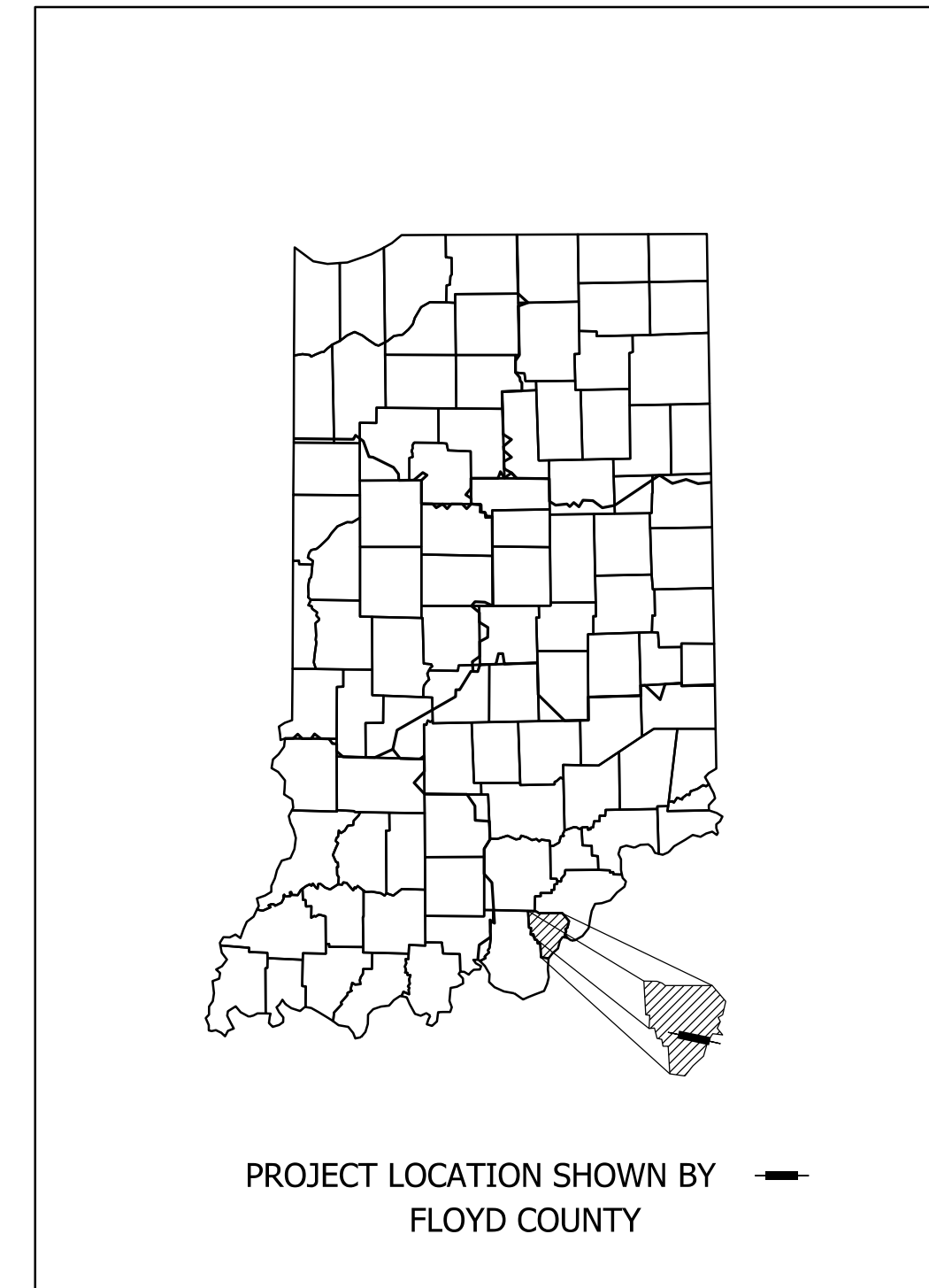

LATITUDE: 38°18'07" N LONGITUDE: 85°51'05" W

BRIDGE LENGTH: 0.060 MI.  
ROADWAY LENGTH: \* MI.  
TOTAL LENGTH: \* MI.  
MAX. GRADE: 3.05 %  
\* SEE DES NO. 1900162

12-DIGIT HYDROLOGIC UNIT CODE: 051401010904

BEGIN CONSTRUCTION  
PROJECT NO. 1900162  
STA. 1025+38.31  
LINE "PR-U-WB"

END CONSTRUCTION  
PROJECT NO. 1900162  
STA. 2077+97.42  
LINE "PR-L-EB"

BEGIN PROJECT  
PROJECT NO. 1900162  
STA. 1180+86.02  
LINE "PR-A-EB"

BRIDGE FILE NO. I64-121-10787  
I-64 WB OVER I-64 EB TO I-265 EB RAMP  
STA. 2292+17.92 "PR-A-WB"

END PROJECT  
PROJECT NO. 1900162  
STA. 1393+50.00  
LINE "PR-A-EB"

**NOTE TO REVIEWER**  
THE LIST OF KIND PROJECTS IS TENTATIVE AND SUBJECT TO CHANGE AT INDOT SEYMOUR DISTRICT'S DIRECTION. THIS LIST REPRESENTS THE CURRENT UNDERSTANDING OF THE CONTRACT PACKAGE.

**STAGE 2 PLANS**

**HNTB**  
HNTB CORPORATION  
THE HNTB COMPANIES  
INFRASTRUCTURE SOLUTIONS  
111 MONUMENT CIRCLE  
SUITE 1200  
INDIANAPOLIS, IN 46204

**DRAFT**  
NOT FOR CONSTRUCTION

PLANS PREPARED BY: HNTB INDIANA, INC (317) 636-4682 PHONE NUMBER  
CERTIFIED BY: \_\_\_\_\_ DATE  
APPROVED FOR LETTING: \_\_\_\_\_ DATE  
INDIANA DEPARTMENT OF TRANSPORTATION

INDIANA DEPARTMENT OF TRANSPORTATION  
STANDARD SPECIFICATIONS DATED 2022  
TO BE USED WITH THESE PLANS

BRIDGE FILE	
I64-121-10787	
DESIGNATION	
1702617	
SURVEY BOOK	SHEETS TTL-01
ELECTRONIC	1 of 34
CONTRACT	PROJECT
R-42570	1900162

gdbiley 5/22/2023; 9:31:20 AM model: TTL-01 [Sheet] file: p:\i\p\hntb\org\PMG\Great\_Lakes\Documents\Indianapolis Projects\78704 INDOT-S I-64 ATL 00 CAD-ORD\Sheets\Bridges\1900162\_S\_TTL05A.dgn

gdalley 5/22/2023; 9:32:05 AM  
 model: FTO-01 [Sheet]  
 file: p:\i\p\in\hmb\org\Indanapolis\Projects\78704 INDOT-S I-64 ATL 00 CAD-ORD\Sheets\Bridges\Bridg No. 5A - I-64 WB over EB to NB Ramp\1900162\_S\_FTO05A.dgn

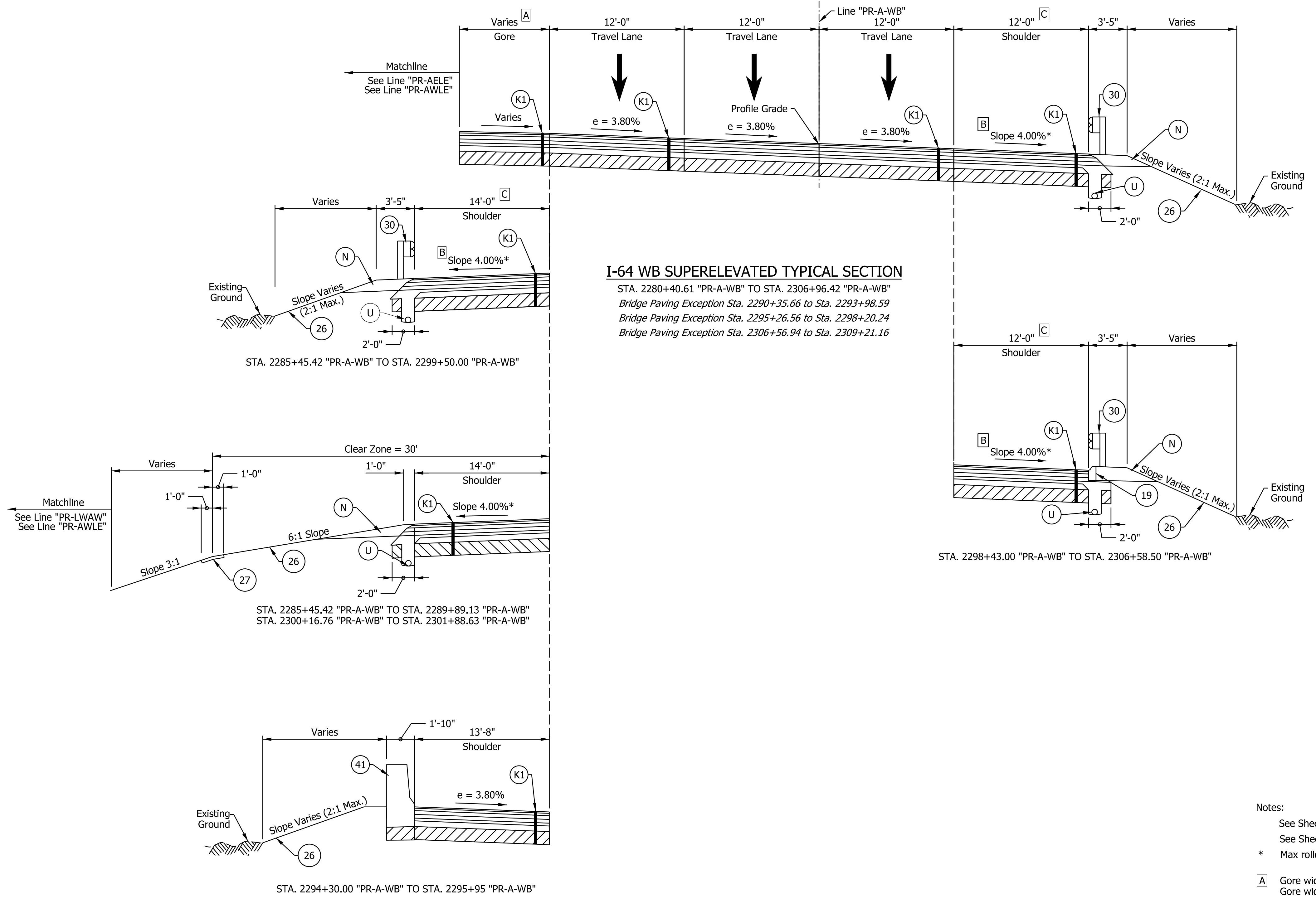

FOR INFORMATION ONLY

- Notes:
- See Sheet LGD-01 for construction legend
  - See Sheet TS-43 for Safety Edge Details
  - \* Max rollover between shoulder and travel lane not to exceed 8%.
  - A** Gore width varies from 0'-0" at Sta. 2280+40.61 to 25'-0" at Sta. 2285+45.42  
 Gore width varies from 30'-0" at Sta. 2301+88.63 to 0'-0" at Sta. 2306+96.82
  - B** Shoulder slope to rotate to match adjacent lane slope on the bridges over the interior system interchange ramps and Captain Frank Road.
  - C** Right shoulder width shall be 12'-4" from Sta. 2290+12.15 to Sta. 2298+43.00

**NOTE TO REVIEWER**  
 Coordination with Geotech is in progress.  
 Retaining Wall Details will be  
 Refined in future Submittals

**NOTE TO REVIEWER**  
 2-foot lane extensions at the shoulders will be  
 reviewed and implemented where applicable  
 in a future submittal.

**DRAFT**  
 NOT FOR CONSTRUCTION

RECOMMENDED FOR APPROVAL _____	DESIGN ENGINEER _____	DATE _____
DESIGNED: _____ SGM _____	DRAWN: _____ CGR _____	
CHECKED: _____ ADR _____	CHECKED: _____ ADR _____	

**INDIANA**  
**DEPARTMENT OF TRANSPORTATION**  
  
**I-64 WESTBOUND MAINLINE**  
**PROPOSED TYPICAL SECTIONS**

HORIZONTAL SCALE	BRIDGE FILE
3/16"=1'-0"	I64-121-10787
VERTICAL SCALE	DESIGNATION
N/A	1702617
SURVEY BOOK	SHEETS
ELECTRONIC	3 of 34
CONTRACT	PROJECT
R-42570	1900162

gdhaley 5/22/2023; 9:32:06 AM  
 model: FTO-02 [Sheet]  
 file: p:\i\p\in\hmb\org\INDOT\I-64\ATL\00 CAD-ORD\Sheets\Bridge\Bridg No. 5A - I-64 WB over EB to NB Ramp\1900162\_S\_FTO05A.dgn

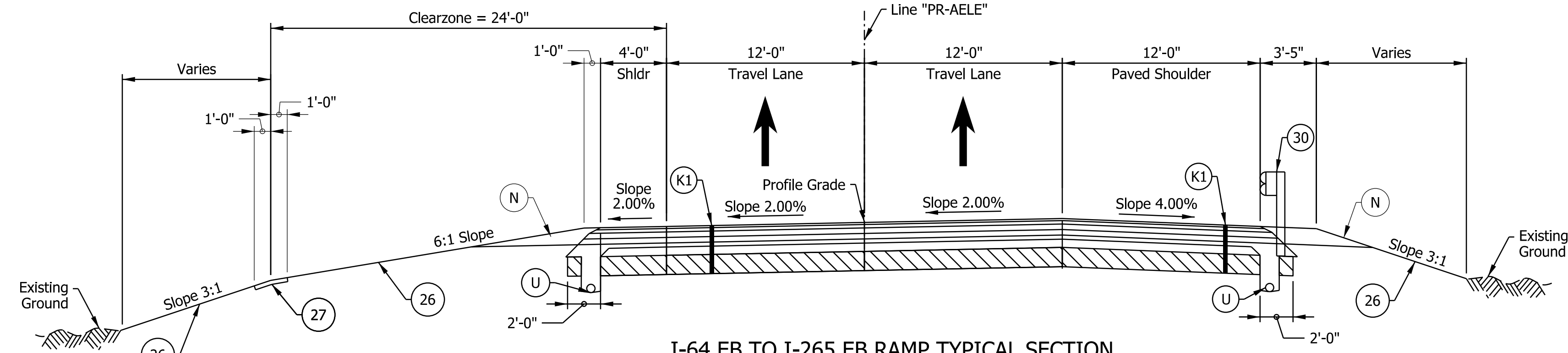

**I-64 EB TO I-265 EB RAMP TYPICAL SECTION**  
 STA. 210+45.00 "PR-AELE" TO STA. 213+51.00 "PR-AELE"

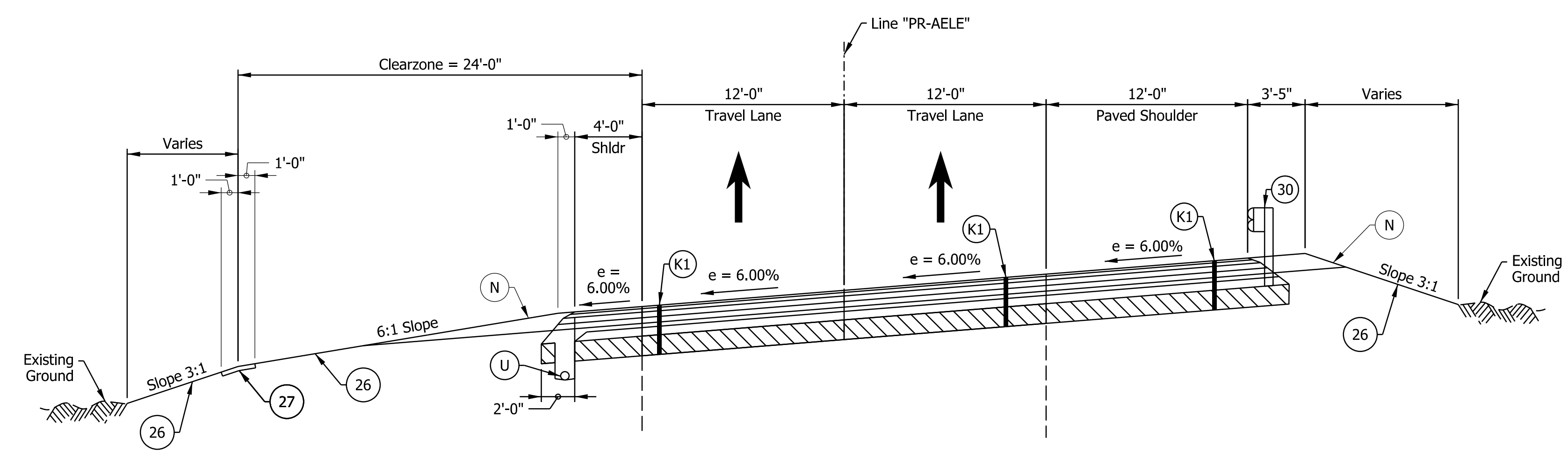

**I-64 EB TO I-265 EB RAMP SUPERELEVATION TYPICAL SECTION**  
 STA. 213+51.00 "PR-AELE" TO STA. 228+83.00 "PR-AELE"

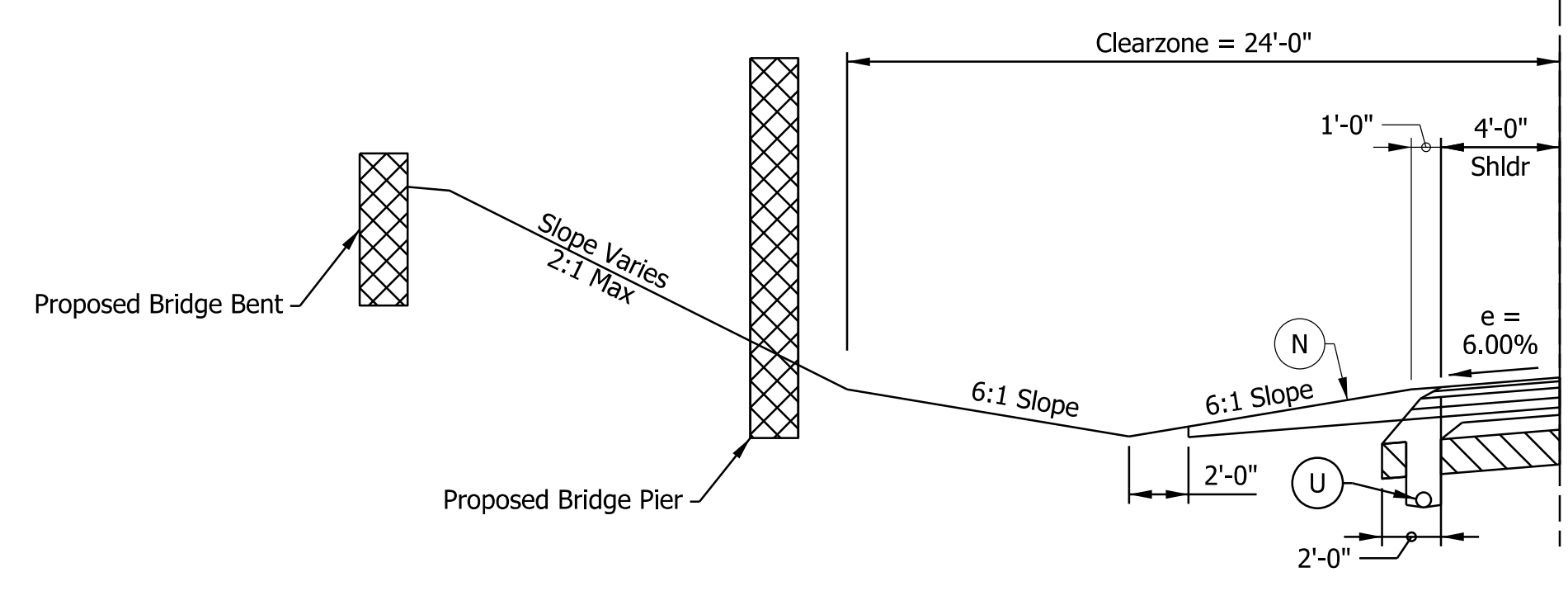

STA. 215+20.00 "PR-AELE" TO STA. 216+50.00 "PR-AELE"  
 STA. 218+80.00 "PR-AELE" TO STA. 219+75.00 "PR-AELE"  
 STA. 224+50.00 "PR-AELE" TO STA. 225+35.00 "PR-AELE"

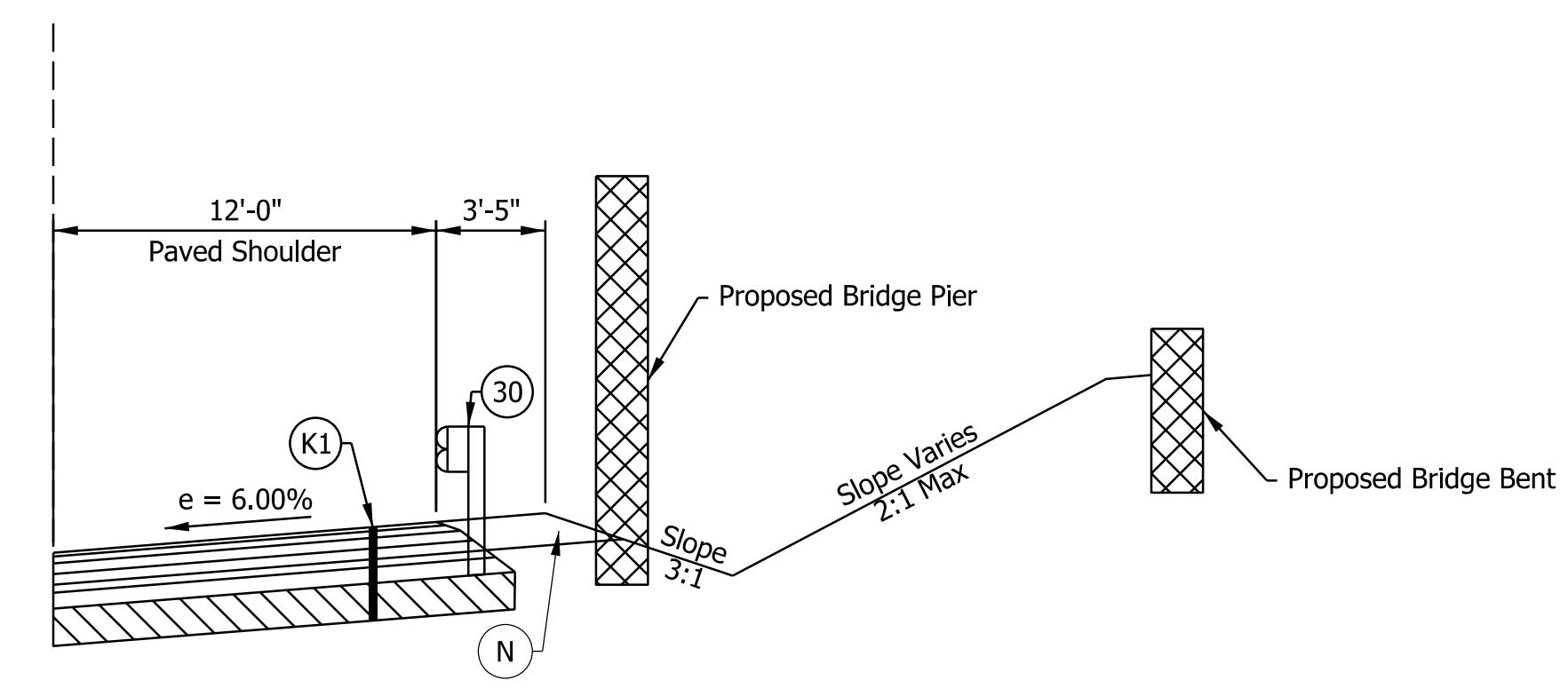

STA. 218+85.00 "PR-AELE" TO STA. 219+75.00 "PR-AELE"  
 STA. 221+10.00 "PR-AELE" TO STA. 222+10.00 "PR-AELE"  
 STA. 223+40.00 "PR-AELE" TO STA. 224+05.00 "PR-AELE"

Notes:  
 See Sheet LGD-01 for construction legend  
 See Sheet TS-43 for Safety Edge Details

**NOTE TO REVIEWER**  
 Locations and details for underdrain trenches and pipes will be reviewed further for the next submittal.

**NOTE TO REVIEWER**  
 Refer to bridge plans for additional information related to slope paving adjacent to piers/bents

FOR INFORMATION ONLY

**DRAFT**  
 NOT FOR CONSTRUCTION

RECOMMENDED FOR APPROVAL	DESIGN ENGINEER	DATE
DESIGNED: DFK	DRAWN: JKH	
CHECKED: ADR	CHECKED: ADR	

INDIANA DEPARTMENT OF TRANSPORTATION  
**I-64 / I-265 INTERCHANGE RAMPS PROPOSED TYPICAL SECTIONS**

HORIZONTAL SCALE	BRIDGE FILE
3/16"=1'-0"	I64-121-10787
VERTICAL SCALE	DESIGNATION
N/A	1702617
SURVEY BOOK	SHEETS
ELECTRONIC	4 of 34
CONTRACT	PROJECT
R-42570	1900162

SEC. 28-T2S-R6E  
NEW ALBANY TOWNSHIP  
FLOYD COUNTY

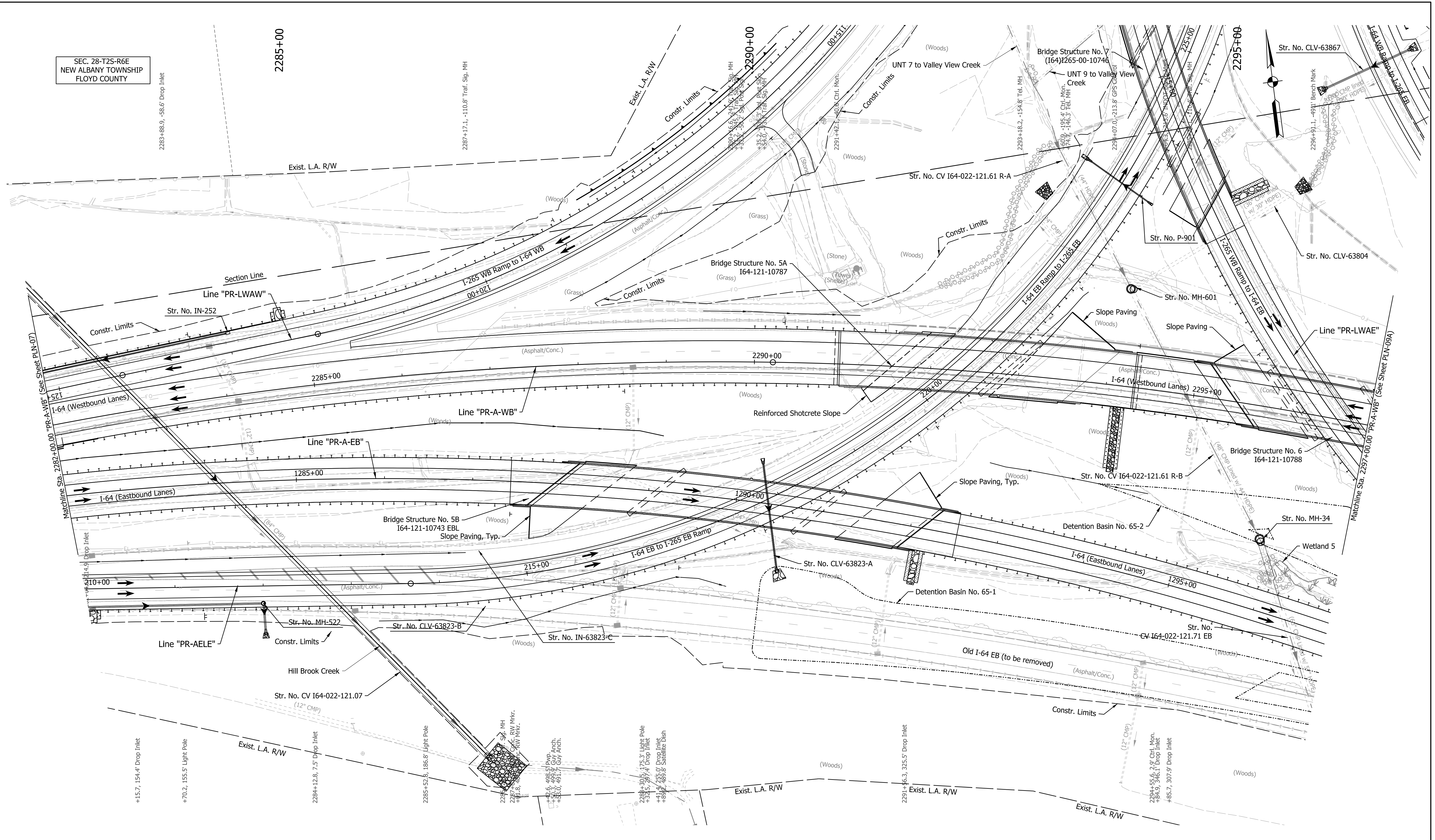

Note:  
For Geometric information see Geometric Layout Sheets  
GEO-01 to GEO-13.

FOR INFORMATION ONLY

**DRAFT**  
NOT FOR CONSTRUCTION

RECOMMENDED FOR APPROVAL _____	DESIGN ENGINEER _____	DATE _____
DESIGNED: _____ SGM	DRAWN: _____ RJS	
CHECKED: _____ KRC	CHECKED: _____ KRC	

INDIANA  
DEPARTMENT OF TRANSPORTATION

PLAN SHEET  
LINE "PR-A-WB"  
STA. 2282+00 TO STA. 2297+00

HORIZONTAL SCALE 1"=50'	BRIDGE FILE 164-121-10787
VERTICAL SCALE N/A	DESIGNATION 1702617
SURVEY BOOK ELECTRONIC	SHEETS PLN-08A 5 of 34
CONTRACT R-42570	PROJECT 1900162

g:\abilley 5/22/2023; 9:32:16 AM model: FTO-03 [Sheet] file: p:\i\p\in\hmb\org\PM\Great\_Lakes\Documents\Indianapolis Projects\78704 INDOT-5 I-64 ATL 00 CAD-ORD\Sheets\Bridges\Bridge No. 5A - I-64 WB over EB to NB Ramp\1900162\_S\_FTO05A.dgn



g:\billy 5/22/2023; 9:32:19 AM  
 model: FTO-05 [Sheet]  
 file: p:\i\p\in\hmb\org\PM\Great\_Lakes\Documents\Indianapolis Projects\78704 INDOT-S I-64 ATL 00 CAD-ORD\Sheets\Bridges\Bridge No. 5A - I-64 WB over EB to NB Ramp\1900162\_S\_FTO05A.dgn

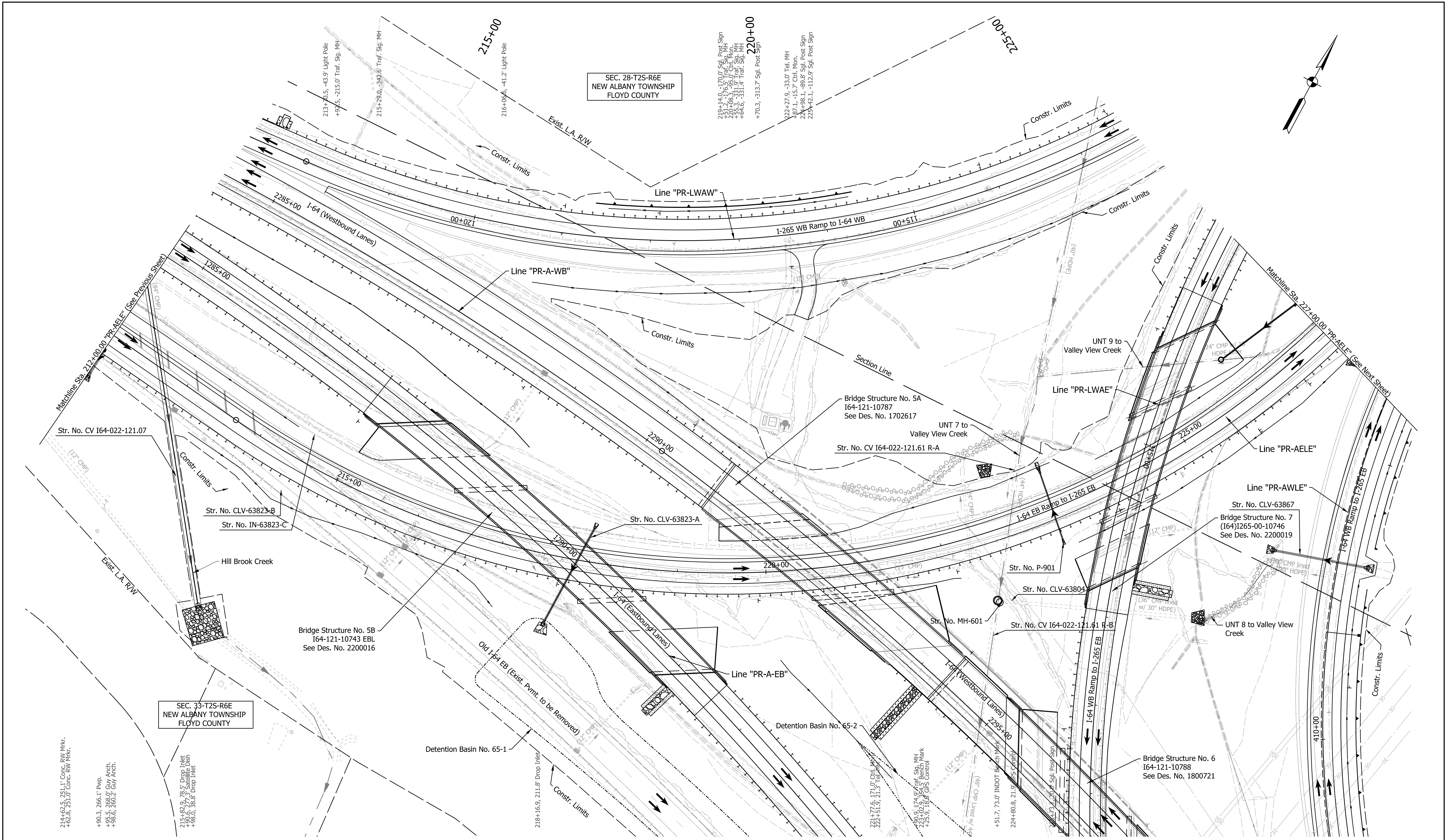

Note:  
 For Geometric information see Geometric Layout Sheets  
 GEO-01 to GEO-13.

FOR INFORMATION ONLY

**DRAFT**  
 NOT FOR CONSTRUCTION

RECOMMENDED FOR APPROVAL	DESIGN ENGINEER	DATE
DESIGNED: SGM	DRAWN: RJS	
CHECKED: KRC	CHECKED: KRC	

INDIANA  
 DEPARTMENT OF TRANSPORTATION

PLAN SHEET  
 LINE "PR-AELE"  
 STA. 212+00 TO STA. 227+00

HORIZONTAL SCALE	BRIDGE FILE	
1"=50'	I64-121-10787	
VERTICAL SCALE	DESIGNATION	
N/A	1702617	
SURVEY BOOK	SHEETS	PLN-40
ELECTRONIC	7	of 34
CONTRACT	PROJECT	
R-42570	1900162	

**NOTE TO REVIEWER**  
 UTILITY COORDINATION IS ONGOING AND ONCE FINALIZED THE EXISTING UTILITIES WILL BE IDENTIFIED AS "TO REMAIN & PROTECT-IN-PLACE", "RELOCATED", OR "ABANDONED" AS REQUIRED.

**EXISTING STRUCTURE**  
 EXISTING STRUCTURE (164-121-04985 RCB) IS A THREE-SPAN (57'-4", 69'-0", & 57'-4") CONTINUOUS STEEL BEAM BRIDGE WITH A 51'-10" CLEAR ROADWAY (TO BE REMOVED)  
 PLANS FOR THE EXISTING BRIDGE ARE ON FILE IN THE RECORDS UNIT OF THE INDIANA DEPARTMENT OF TRANSPORTATION AS BRIDGE FILE 164-121-4985.

**EARTHWORK TABULATION**  
 FOR EARTHWORK SUMMARY, SEE ROAD PLANS DES. NO. 1900162

**HORIZONTAL CURVE DATA FOR LINE "PR-A-WB"**

CURVE 17	CURVE 18
P.I. = 2285+58.51 "PR-A-WB"	P.I. = 2303+73.18 "PR-A-WB"
$\Delta = 13^\circ 22' 51.24" \text{ RT}$	$\Delta = 39^\circ 07' 32.28" \text{ RT}$
$D = 01^\circ 26' 24.82"$	$D = 01^\circ 30' 20.35"$
R = 3978.24'	R = 3805.38'
T = 466.66'	T = 1352.25'
L = 929.08'	L = 2598.58'
E = 27.28'	E = 233.12'
DS = 70MPH	DS = 70MPH
e = 3.80%	e = 3.80%

**HORIZONTAL CURVE DATA FOR LINE "PR-A-E"**

CURVE 49
P.I. = 224+00.52 "PR-A-E"
$\Delta = 93^\circ 29' 31.14" \text{ LT}$
$D = 05^\circ 53' 40.66"$
R = 972.00'
T = 1033.12'
L = 1586.05'
E = 446.49'
DS = 55MPH
e = 6.00%

- NOTES:**
- FOR REFERENCE TIES AND BENCHMARKS, SEE ROAD PLANS, DES. NO. 1900162.
  - FOR DITCH GRADES & GUARDRAIL LIMITS, SEE ROAD PLANS, DES. NO. 1900162.
  - FOR EXISTING AND PROPOSED UTILITIES, DRAINAGE, LIGHTING, SIGNING, AND ITS, SEE DES. NO. 1900162

**LEGEND**  
 \* ROADWAY ITEM - SEE DES 1900162

**CONTINUOUS COMPOSITE PRESTRESSED CONCRETE BULB-TEE BEAM BRIDGE**  
 2 SPANS: 138'-0" & 90'-0"  
 61'-8" CLEAR ROADWAY SKEW: 45° RT.  
 I-64 WB OVER I-64 EB TO I-265 EB RAMP  
 FLOYD COUNTY

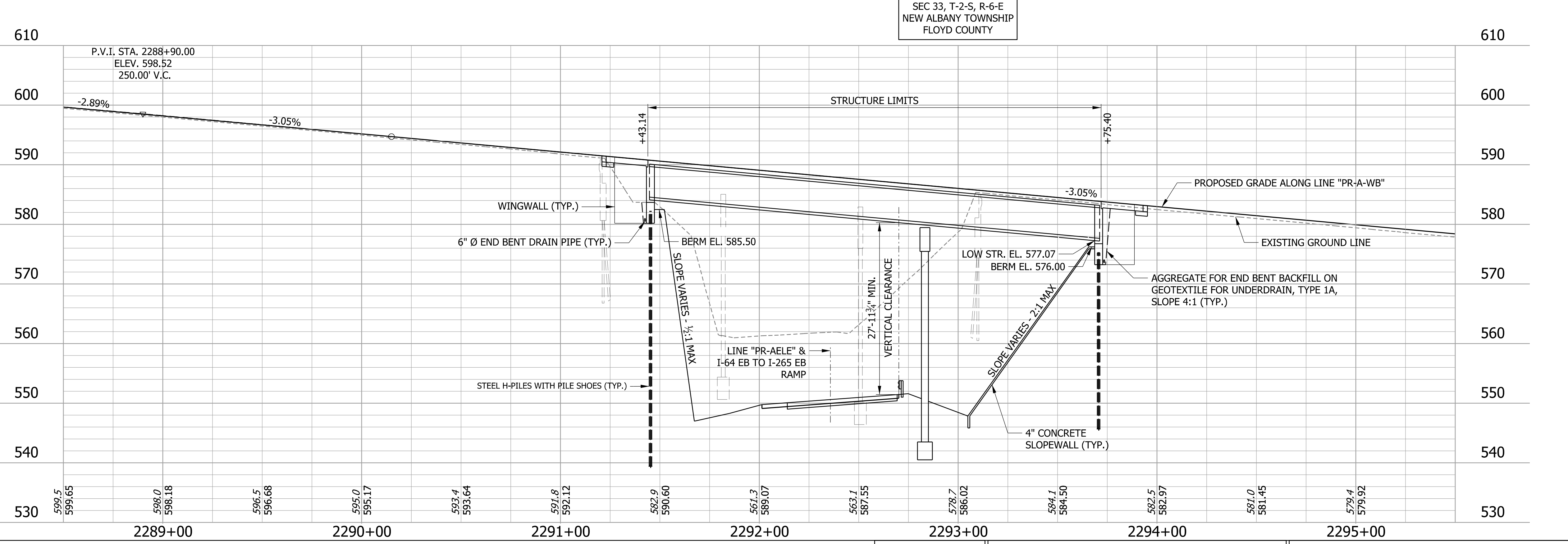
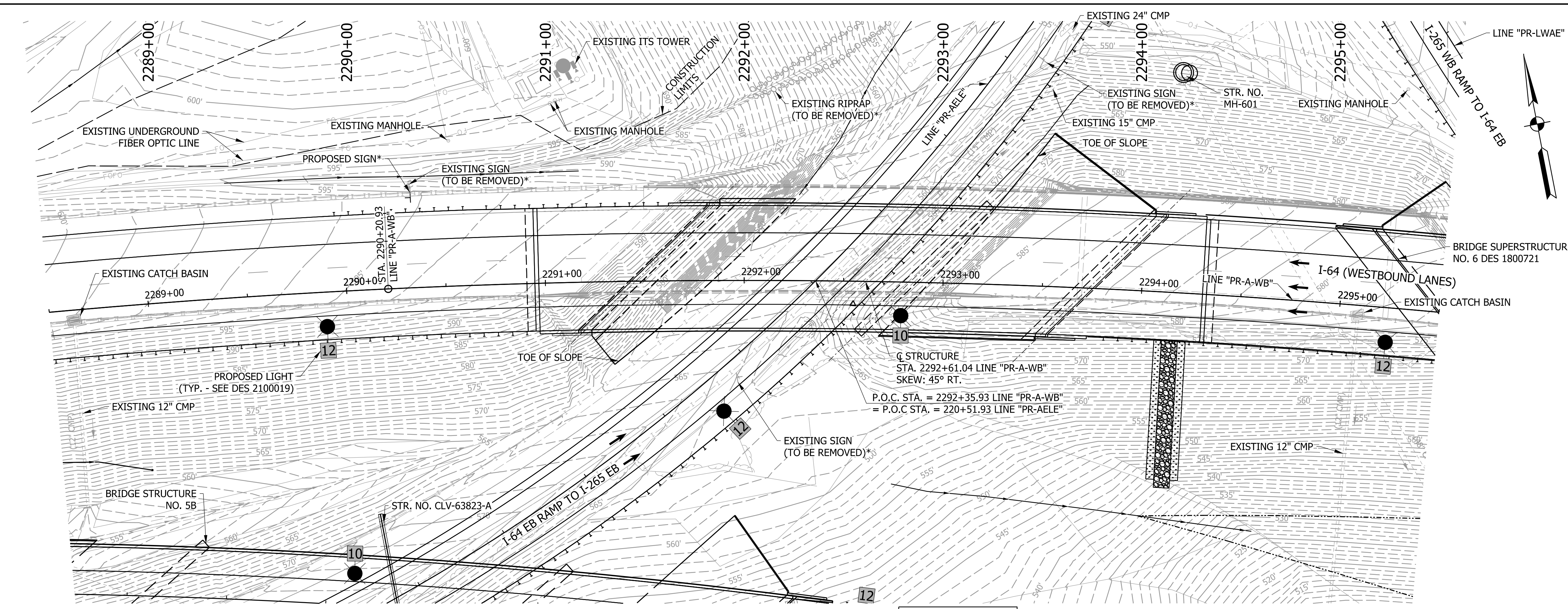

<b>DRAFT</b> NOT FOR CONSTRUCTION	RECOMMENDED FOR APPROVAL _____	DESIGN ENGINEER _____	DATE _____	INDIANA DEPARTMENT OF TRANSPORTATION																
	DESIGNED: PTT	DRAWN: PTT		LAYOUT - LINE "PR-A-WB"																
	CHECKED: JMR	CHECKED: JMR																		
				<table border="1"> <tr> <th>HORIZONTAL SCALE</th> <th>BRIDGE FILE</th> </tr> <tr> <td>1"=30'</td> <td>164-121-10787</td> </tr> <tr> <th>VERTICAL SCALE</th> <th>DESIGNATION</th> </tr> <tr> <td>1"=10'</td> <td>1702617</td> </tr> <tr> <th>SURVEY BOOK</th> <th>SHEETS</th> </tr> <tr> <td>ELECTRONIC</td> <td>12 of 34</td> </tr> <tr> <th>CONTRACT</th> <th>PROJECT</th> </tr> <tr> <td>R-42570</td> <td>1900162</td> </tr> </table>		HORIZONTAL SCALE	BRIDGE FILE	1"=30'	164-121-10787	VERTICAL SCALE	DESIGNATION	1"=10'	1702617	SURVEY BOOK	SHEETS	ELECTRONIC	12 of 34	CONTRACT	PROJECT	R-42570
HORIZONTAL SCALE	BRIDGE FILE																			
1"=30'	164-121-10787																			
VERTICAL SCALE	DESIGNATION																			
1"=10'	1702617																			
SURVEY BOOK	SHEETS																			
ELECTRONIC	12 of 34																			
CONTRACT	PROJECT																			
R-42570	1900162																			

c:\p\5\22\2023\9:33:09 AM 5/22/2023 9:33:09 AM model: P1N-01 [Sheet] file: p:\p\5\22\2023\9:33:09 AM\INDOT-S I-64 ATL 00 CAD-ORD\Sheets\Bridges\Bridges No. 5A - I-64 WB over EB to NB Ramp\1900162\_S\_LAY05A.dgn



**GENERAL NOTES**

REINFORCING BARS IN DECK, BARRIER, AND END BENT DIAPHRAGM AND CAP SHALL BE EPOXY COATED.

REINFORCING BAR COVER SHALL BE 2 1/2" IN TOP AND 1" MINIMUM IN THE BOTTOM OF THE FLOOR SLAB, 3" IN FOOTINGS EXCEPT BOTTOM BARS WHICH SHALL BE 4" MIN., AND 2" IN ALL OTHER PARTS, UNLESS OTHERWISE NOTED.

ALL EXPOSED FACES OF THE CONCRETE BRIDGE RAILINGS, CONCRETE RAILING TRANSITIONS, WINGWALLS, AND END BENTS SHALL BE SURFACE SEALED.

ALL DIMENSIONS AND ELEVATIONS ARE IN FEET (FT) UNLESS OTHERWISE NOTED.

**DESIGN DATA**

**LIVE LOAD**  
DESIGNED FOR HL-93 LOADING IN ACCORDANCE WITH AASHTO LRFD BRIDGE DESIGN SPECIFICATIONS NINTH EDITION, 2020, AND SUBSEQUENT INTERIMS.

**DEAD LOAD**  
DESIGNED FOR ACTUAL DEAD LOAD PLUS 35 PSF OF FUTURE WEARING SURFACE AND 15 PSF FOR SIP METAL DECK FORMS.

**FLOOR SLAB**  
SLAB DESIGNED WITH A 7 1/2" STRUCTURAL DEPTH AND A 1/2" INTEGRAL WEARING SURFACE.

**DESIGN STRENGTHS**

CLASS "C" CONCRETE	f <sub>c</sub> = 4,000 psi
CLASS "A" CONCRETE	f <sub>c</sub> = 3,500 psi
CLASS "B" CONCRETE	f <sub>c</sub> = 3,000 psi
REINFORCING BARS	f <sub>y</sub> = 60,000 psi
PRESTRESSED CONCRETE, NORMAL WEIGHT:	
f <sub>c</sub> = 8,000 PSI @ 28 DAYS	
INITIAL f <sub>c</sub> = 6,000 PSI @ RELEASE OF STRANDS	
PRESTRESSING STRANDS:	
0.6" Ø 7 WIRE LOLAX STRANDS (A <sub>s</sub> = 0.217 SQ. IN.)	
ULT. TENSILE STRENGTH = 270,000 PSI	
INITIAL PULL = 43,940 LBS. PER STRAND	

**CONSTRUCTION LOADING**  
THE EXTERIOR BEAMS HAVE BEEN CHECKED FOR STRENGTH, DEFLECTION, AND OVERTURNING USING CONSTRUCTION LOADS SHOWN BELOW. CANTILEVER OVERHANG BRACKETS WERE ASSUMED FOR SUPPORT OF THE DECK OVERHANG PAST THE EDGE OF EXTERIOR BEAM. THE FINISHING MACHINE WAS ASSUME TO BE SUPPORTED 6 INCHES OUTSIDE THE VERTICAL COPING FORM. THE TOP OVERHANG BRACKETS WERE ASSUMED TO BE LOCATED 6 INCHES PAST THE EDGE OF THE VERTICAL COPING FORM. THE BOTTOM OVERHANG BRACKETS WERE ASSUMED TO BE BRACED AGAINST THE INTERSECTION OF THE BEAM BOTTOM FLANGE AND WEB.

**DECK FALSEWORK LOADS:**  
DESIGNED FOR 15 LBS/SFT FOR PERMANENT METAL STAY-IN-PLACE DECK FORMS, REMOVABLE DECK FORMS, AND 2-FT. EXTERIOR WALKWAY.

**CONSTRUCTION LIVE LOAD:**  
DESIGNED FOR 20 LB/SFT EXTENDING 2 FT. PAST THE EDGE OF COPING AND 75 LB/FT VERTICAL FORCE APPLIED AT A DISTANCE OF 6 INCHES OUTSIDE THE FACE OF COPING OVER A 30-FT. LENGTH OF THE DECK CENTERED WITH THE FINISHING MACHINE.

**FINISHING-MACHINE LOAD:**  
4500 LB DISTRIBUTED OVER 10 FT. ALONG THE COPING.

**WIND LOAD**  
DESIGNED FOR 70 MPH HORIZONTAL WIND LOADING IN ACCORDING WITH ASSHTO LRFD 3.8.1.

**SEISMIC DATA**  
SEISMIC PERFORMANCE ZONE = X  
ACCELERATION COEFFICIENT = X  
SEISMIC SOIL PROFILE TYPE = SITE CLASS X

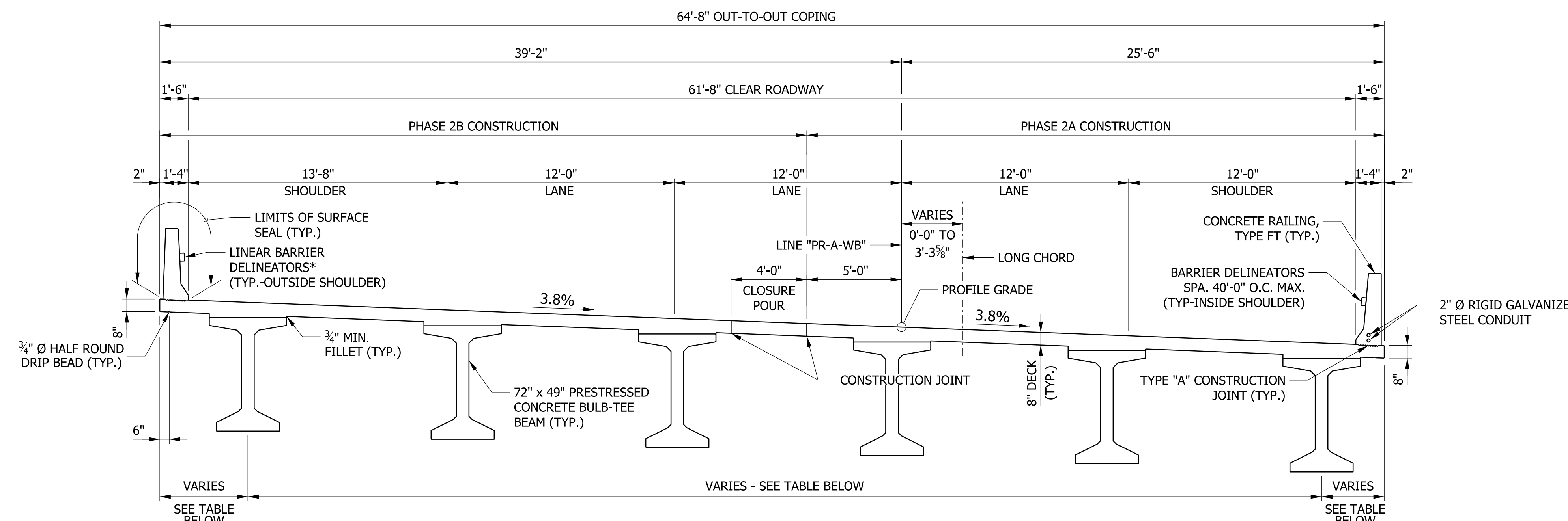

**TYPICAL SECTION**  
(LOOKING AHEAD STATION)  
SCALE: 1/4" = 1'-0"

TYPICAL SECTION BEAM SPACING AND OVERHANG DIMENSIONS			
SPAN	BEAM SPACING	OVERHANG DIMENSION	
		NORTH COPING	SOUTH COPING
A	11'-1"	VARIES 1'-7 1/4" MIN. TO 2'-10 5/8" MAX.	VARIES 2'-0" MIN. TO 3'-1 3/4" MAX.
B	11'-5"	VARIES 0'-8 7/8" MIN. TO 1'-7 1/8" MAX.	VARIES 1'-8 3/4" MIN. TO 2'-3 1/2" MAX.

**NOTE TO REVIEWER**  
ADDITIONAL DETAIL FOR THE MODIFIED CONCRETE CURB AND MODIFIED CONCRETE TURNOUT WILL BE PROVIDED IN STAGE 3.

**NOTE TO REVIEWER**  
SEISMIC DATA WILL BE PROVIDED IN A FUTURE SUBMITTAL ONCE THE GEOTECHNICAL REPORT IS COMPLETE.

**LEGEND**  
\* SEE SPECIAL PROVISIONS FOR LINEAR BARRIER DELINEATOR REQUIREMENTS.

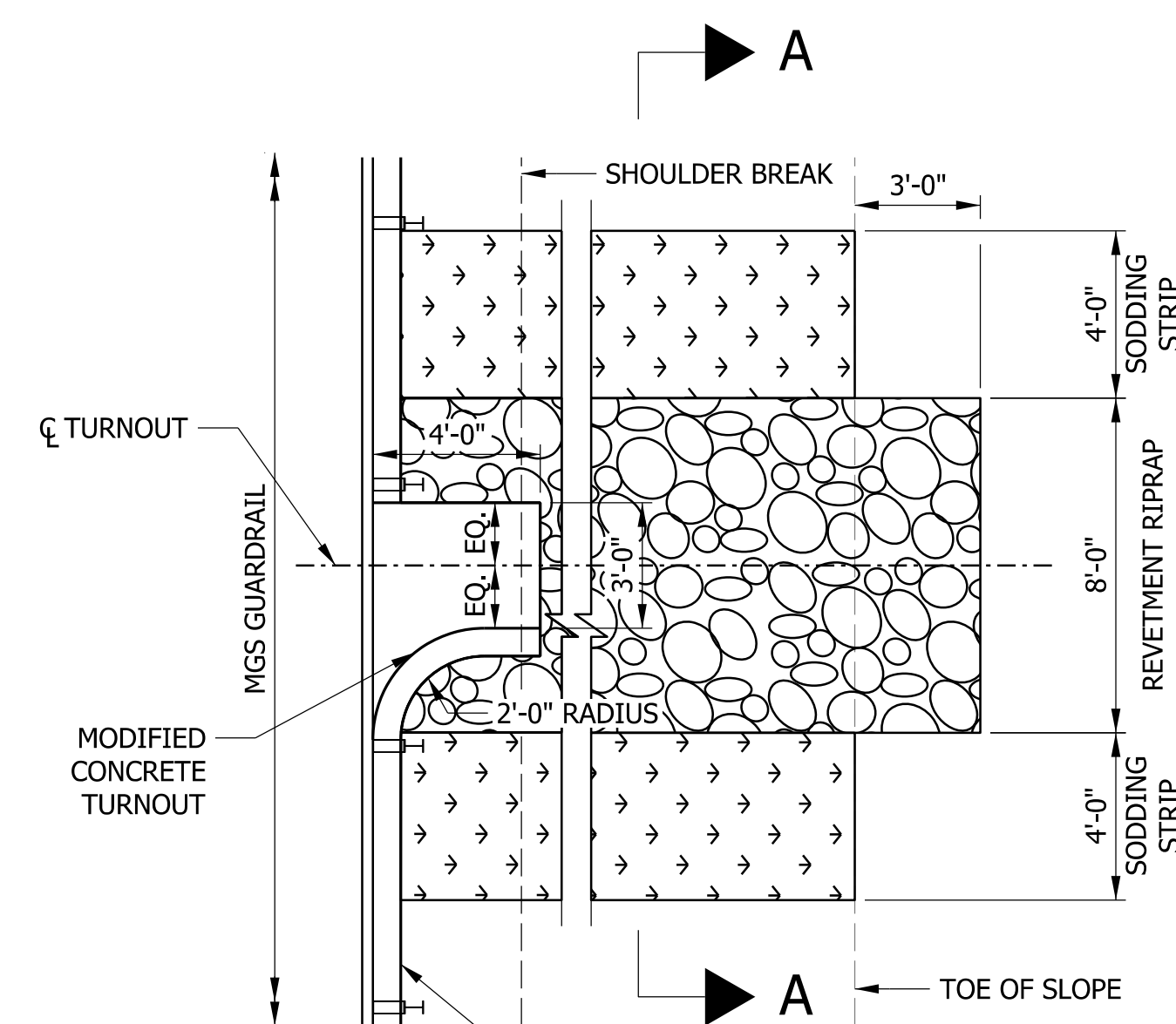

**PLAN**

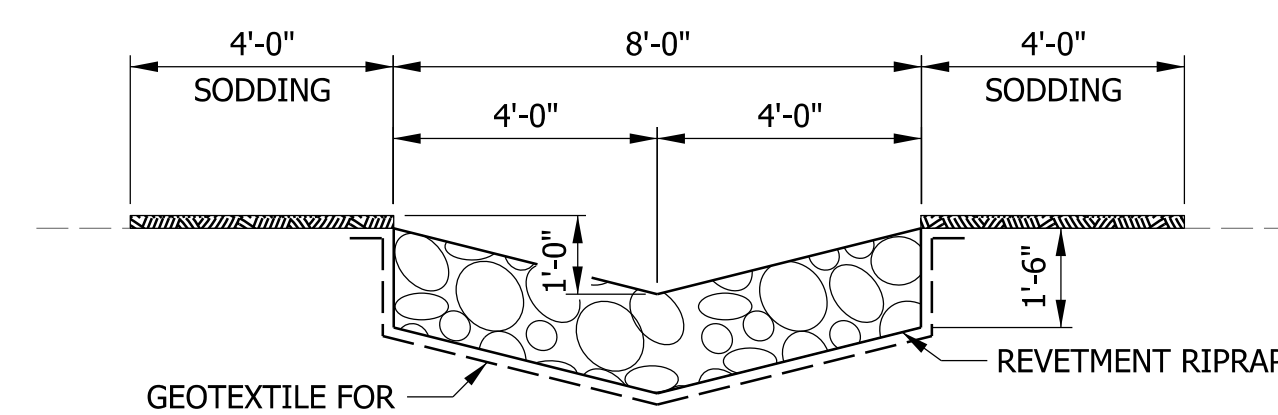

**SECTION A-A**

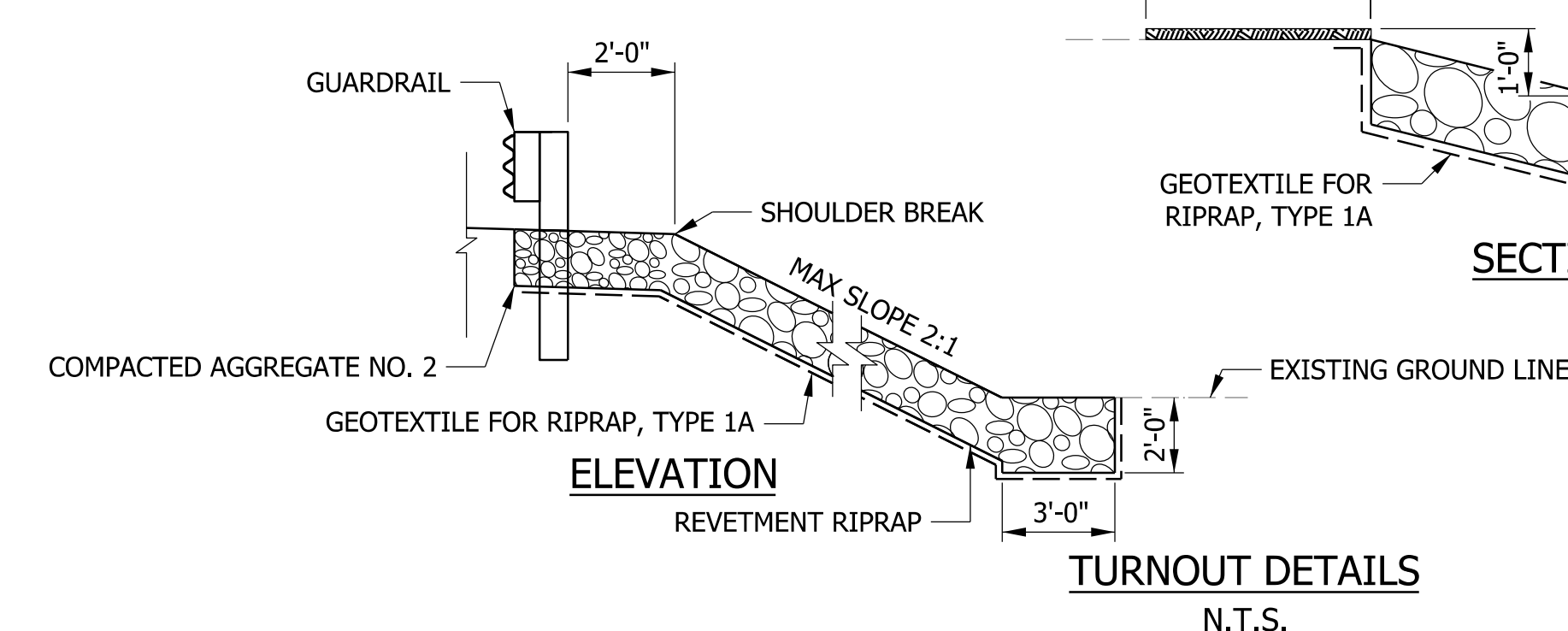

**ELEVATION**

**TURNOUT DETAILS**  
N.T.S.

**CONTINUOUS COMPOSITE PRESTRESSED CONCRETE BULB-TEE BEAM BRIDGE**  
2 SPAN: 138'-0" & 90'-0"  
61'-8" CLEAR ROADWAY      SKEW: 45°  
I-64 WB OVER I-64 EB TO I-265 EB RAMP  
FLOYD COUNTY

j:\modnick\5/22/2023\9:34:36 AM\modnick\_TYP-01 [Sheet].dwg  
file: p:\i\p\i\h\mb\org\PM\Great\_Lakes\Documents\Indianapolis\Projects\78704 INDOT-S I-64 ATL\00 CAD-ORD\Sheets\Bridges\Bridges\No. 54 - I-64 WB over EB to NB Ramp\1900162\_S\_1\_TYP05A.dgn

**DRAFT**  
NOT FOR CONSTRUCTION

RECOMMENDED FOR APPROVAL _____	DESIGN ENGINEER _____	DATE _____
DESIGNED: _____ PTT _____	DRAWN: _____ PTT _____	
CHECKED: _____ JMR _____	CHECKED: _____ JMR _____	

**INDIANA DEPARTMENT OF TRANSPORTATION**

**GENERAL PLAN**

HORIZONTAL SCALE	BRIDGE FILE
AS SHOWN	164-121-10787
VERTICAL SCALE	DESIGNATION
AS SHOWN	1702617
SURVEY BOOK	SHEETS
ELECTRONIC	14 of 34
CONTRACT	PROJECT
R-42570	1900162

PROJECT	DESIGNATION
1900162	2200016
CONTRACT	BRIDGE FILE
R-42570	I64-121-10743 EBL

STRUCTURE INFORMATION				
STRUCTURE	TYPE	SPAN AND SKEW	OVER	STATION
I64-121-10743 EBL	CONTINUOUS COMPOSITE CURVED STEEL PLATE GIRDER	3 SPANS: 115'-0", 185'-0", 115'-0" SKEW = 45° RT.	I-64 EB RAMP TO I-265 EB	Ç STRUCTURE STA. 1290+02.69 "PR-A-EB"

# INDIANA DEPARTMENT OF TRANSPORTATION

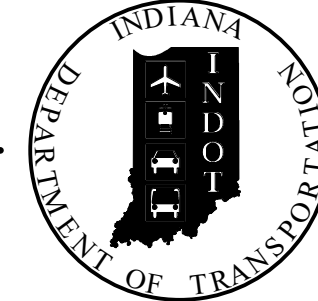

## BRIDGE PLANS

FOR SPANS OVER 20 FEET  
ROUTE: I-64 EB AT: RP 121+71

PROJECT NO. 2200016 P.E.  
1900162 R/W  
2200016 CONST.

New Construction on I-64 EB over I-64 EB Ramp to I-265 EB  
Located 2.11 Miles East of US 150 in  
Section 33, T-2-S, R-6-E, New Albany Township, Floyd County, Indiana

DESIGNATION	PROJECT DESCRIPTION		LEAD DES.
ROAD			
1900162	I-64 ATL		
1900366	US 150 and Old Vincennes Road (East)		
2100019	I-64 Lighting US 150 to I-64 / I-265		
BRIDGE			
1800706	Bridge Painting on US 150 EB over I-64, Str.No. 150-22-04983 AEBL	STR. 1	
1800405	Bridge Painting on US 150 EB over I-64, Str.No. 150-22-04983 AWBL	STR. 2	
1700207	Bridge Replacement on I-64 EB over Quarry Road, Str.No. 164-120-10786	STR. 3	
2200015	Bridge Replacement on I-64 WB over Quarry Road, Str.No. 164-120-10742	STR. 4	
1702617	Bridge Replacement on I-64 WB over I-64 EB to I-265 EB Ramp, Str.No. 164-121-10787	STR. 5A	
2200016	New Bridge on I-64 EB over I-64 EB Ramp to I-265 EB, Str.No.164-121-10743 EBL	STR. 5B	
1800721	Bridge Replacement on I-64 WB over I-265 WB Ramp to I-64 EB, Str.No.164-121-10788	STR. 6	
2200019	Bridge Replacement on I-265 WB to I-64 EB Ramp over I-64 EB to I-265 EB Ramp, Str.No.(164)I265-00-10746	STR. 7	
2200017	Bridge Replacement on I-64 EB over Captain Frank Road, Str.No.164-121-10744	STR. 8	
2200018	Superstructure Replacement on I-64 WB over Captain Frank Road, Str. No. 164-121-04986 DWBL	STR. 9	
1702614	Bridge Deck Overlay on I-64 over Cherry Street, Str.No. 164-122-04988 D	STR. 10	
2000326 / 2000323	Bridge Deck Replacement & Widening on I-265 EB & Ramp Over State Street, Str.No. 1265-00-05513 JCEB & DRCB	STR. 11	
2000324	Bridge Deck Overlay on I-265 WB Over State Street, Str.No. 1265-00-05513 DWBL	STR. 12	
1700206	Bridge Deck Replacement I-64 EB over SR 62/ SR 64	STR. 13	
1700205	Bridge Deck Replacement on I-64 WB over SR 62/ SR 64	STR. 14	
2000144	Bridge Deck Overlay on I-64 EB over Yenowine Lane	STR. 15	
2000145	Bridge Deck Overlay on I-64 WB over Yenowine Lane	STR. 16	
2002072	US 150 EB over Little Indian Creek, Str.No.150-22-05230 CEB	STR. 18	
2002073	US 150 WB over Little Indian Creek, Str.No.150-22-05230 CWB	STR. 19	
2200719	I-64 EB & WB over SR 62 / Spring Street, Str.No.164-123-04689 C	STR. 20	
2200718	I-64 WB Off-Ramp to Spring Street over I-64 WB On-Ramp from Spring Street, Str.No.164-123-04688 D	STR. 21	
DRAINAGE			
TBD	US 150 Twin Arch Pipe Liner	STR. 17	
TBD	Valley View Creek (6 Small Structures and 7 Small Pipe Replacements)		
TBD	Valley View Creek CMP Liner		
TBD	UNT to Little Indian Creek CMP Liner		
TBD	Hill Brook CMP Liner		
TBD	Small Pipes CMP Liners (2)		

TRAFFIC DATA		I-64 EB MAINLINE	I-64 EB TO I-265 EB
A.A.D.T.	(2019)	18,020 V.P.D.	16,500 V.P.D.
A.A.D.T.	(2046)	24,240 V.P.D.	22,650 V.P.D.
D.H.V.	(2046)	3,050 V.P.H.	1,290 V.P.H.
DIRECTIONAL DISTRIBUTION		100 %	100 %
TRUCKS		12 % A.A.D.T.	8 % A.A.D.T.
		4 % D.H.V.	9 % D.H.V.

DESIGN DATA		70 M.P.H.	55 M.P.H.
DESIGN SPEED			
PROJECT DESIGN CRITERIA	NEW CONSTRUCTION (FREEWAY)		RECONSTRUCTION
FUNCTIONAL CLASSIFICATION	INTERSTATE		RAMP
RURAL/URBAN		URBAN	URBAN
TERRAIN		ROLLING	ROLLING
ACCESS CONTROL		FULL	FULL

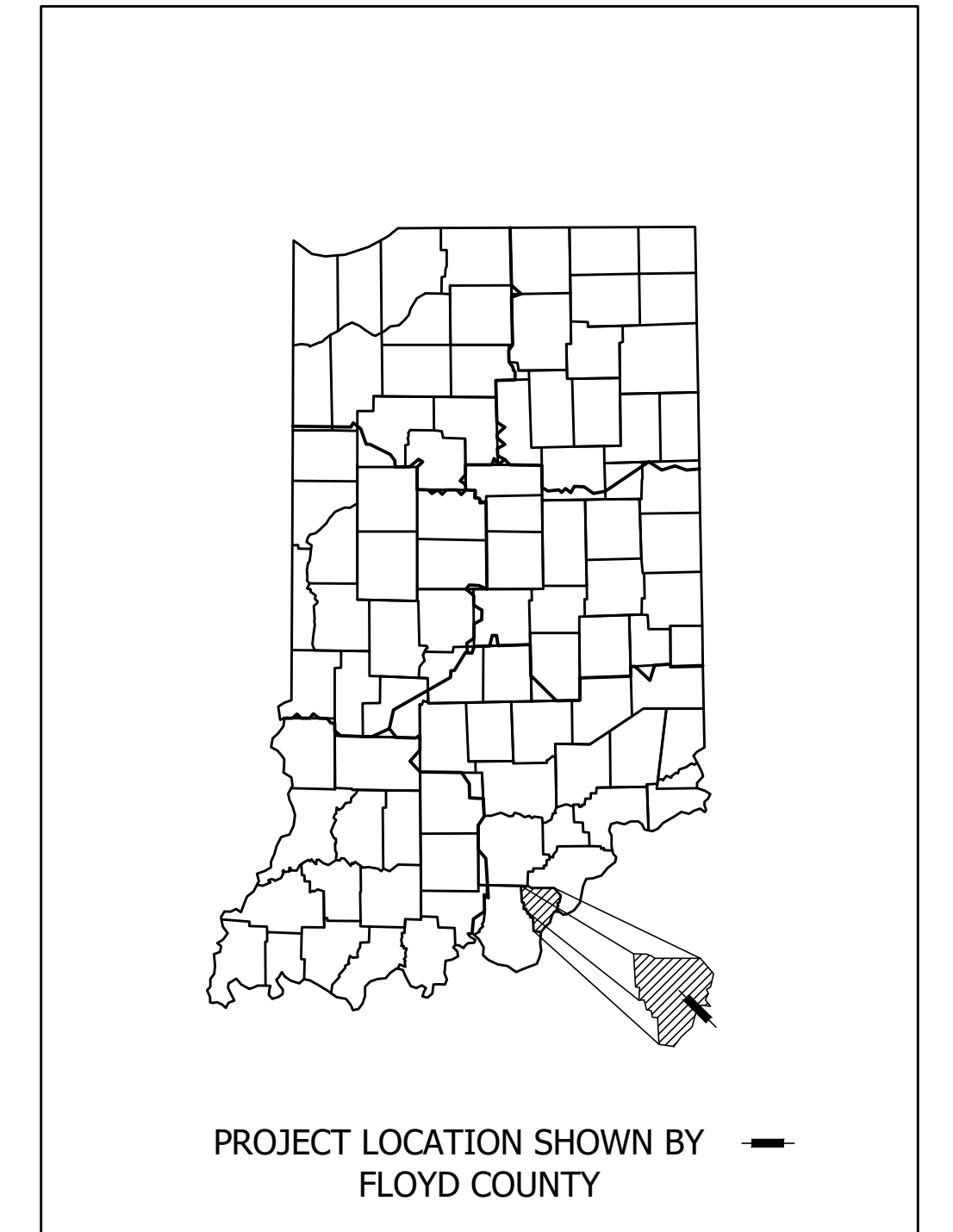

LATITUDE: 38°18'5.89" N LONGITUDE: 85°51'7.89" W

BRIDGE LENGTH: 0.079 MI.  
ROADWAY LENGTH: \* MI.  
TOTAL LENGTH: \* MI.  
MAX. GRADE: -4.50 %

\* SEE DES. NO. 1900162

HUC 12: 051401010904  
HUC 14: 05140101150020

BEGIN CONSTRUCTION  
Sta.1025+38.31 Line "PR-U-WB"

BEGIN PROJECT  
Sta.1180+86.02 Line "PR-A-EB"

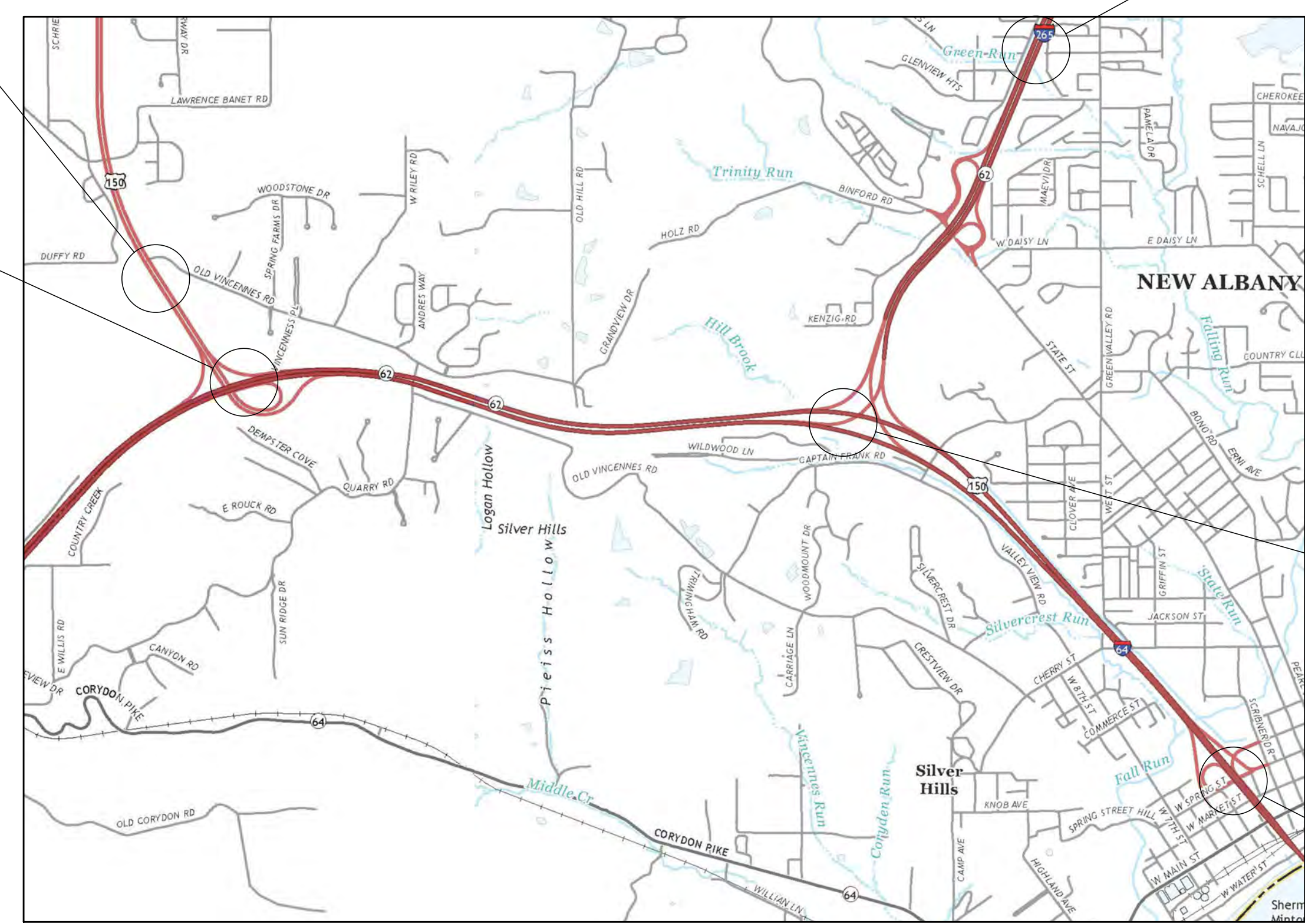

END CONSTRUCTION  
Sta.2077+97.42 Line "PR-L-EB"

STRUCTURE LOCATION  
Ç Str.-Sta.1290+02.69 "PR-A-EB"

END PROJECT  
Sta.1393+50.00 Line "PR-A-EB"

LOCATION MAP  
SCALE: 1" = 2000'

Note to Reviewer:  
The list of Kinned Projects is tentative and subject to change at INDOT Seymour District's direction. This list represents the current understanding of the Contract Package

### STAGE 2 PLANS

PLANS PREPARED BY:

8320 CRAIG STREET | INDIANAPOLIS, IN 46250  
317.849.5832 | F. 317.841.4280 | WWW.B-L-N.COM

**DRAFT**  
NOT FOR CONSTRUCTION

PLANS PREPARED BY:	BEAM, LONGEST & NEFF, LLC	(317)849-5832 PHONE NUMBER
CERTIFIED BY:		DATE
APPROVED FOR LETTING:	INDIANA DEPARTMENT OF TRANSPORTATION	DATE

INDIANA DEPARTMENT OF TRANSPORTATION STANDARD SPECIFICATIONS DATED 2022 TO BE USED WITH THESE PLANS.	
BRIDGE FILE	164-121-10743 EBL
DESIGNATION	2200016
DRAWING NO.	1 of 27
CONTRACT	R-42570
PROJECT	1900162

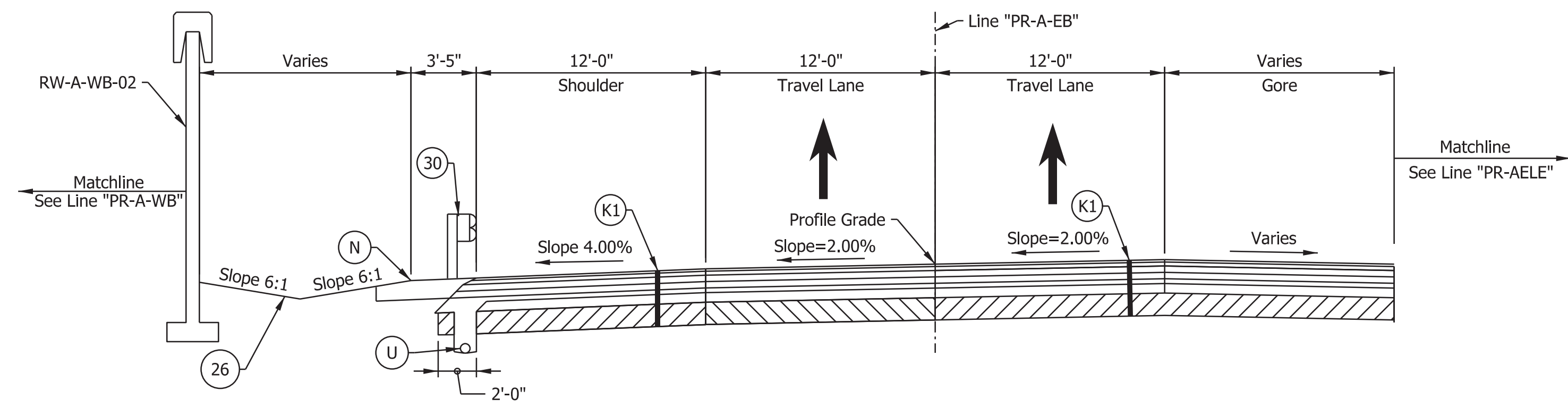

**I-64 EB TYPICAL SECTION**  
 STA. 1272+44.97 "PR-A-EB" TO STA. 1277+60.00 "PR-A-EB"

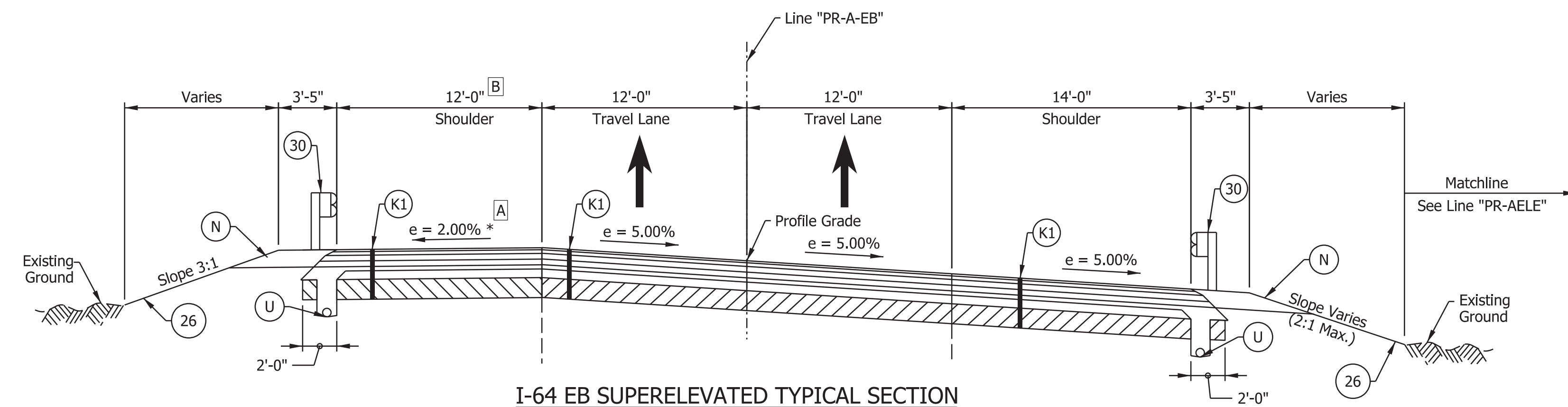

**I-64 EB SUPERELEVATED TYPICAL SECTION**  
 STA. 1277+60.00 "PR-A-EB" TO STA. 1299+86.00 "PR-A-EB"  
 Bridge Paving Exception from Sta. 1287+44.34 to 1292+52.04

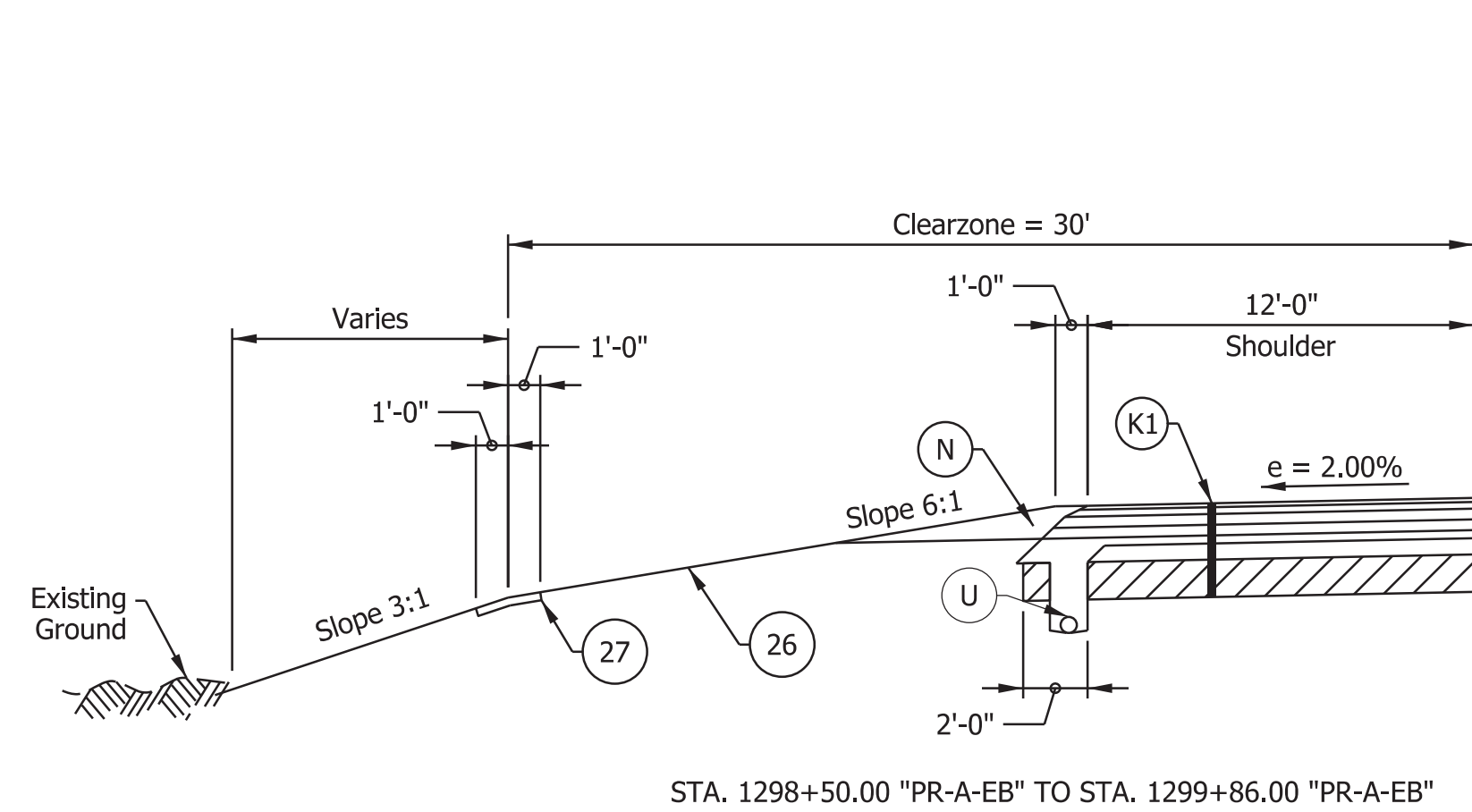

STA. 1298+50.00 "PR-A-EB" TO STA. 1299+86.00 "PR-A-EB"

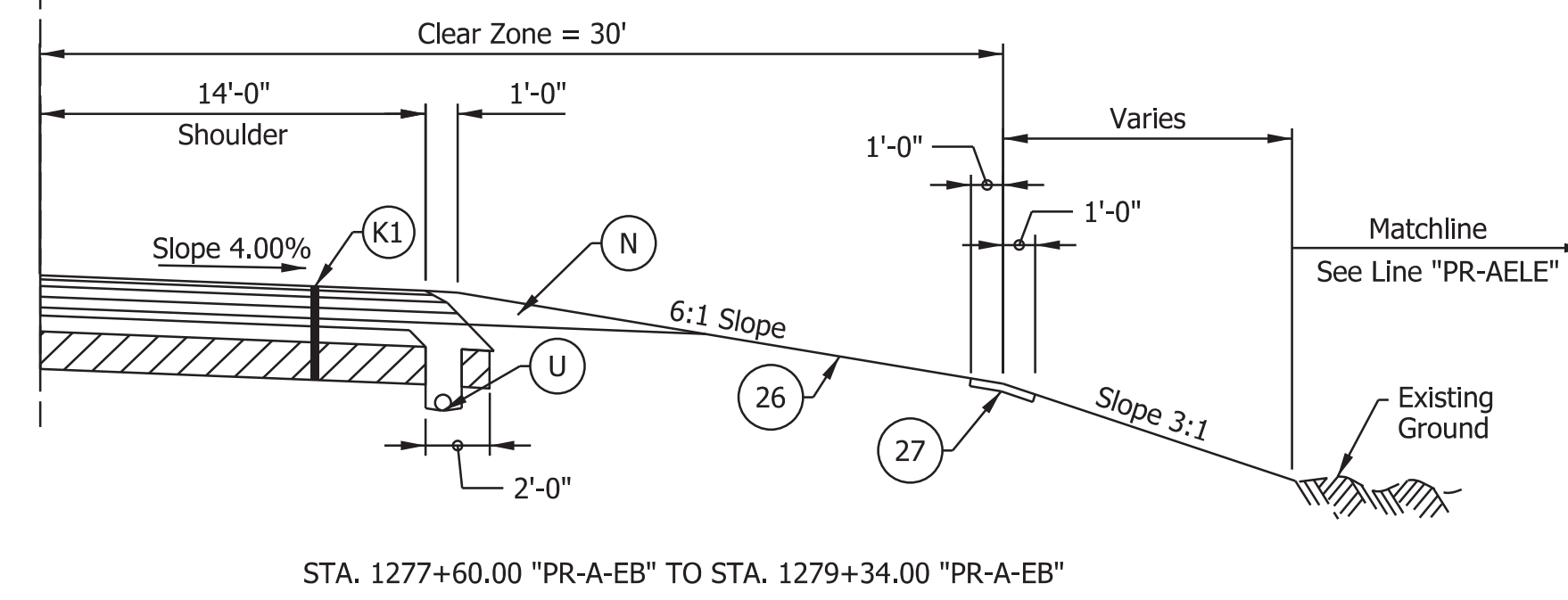

STA. 1277+60.00 "PR-A-EB" TO STA. 1279+34.00 "PR-A-EB"

- Notes:
- See Sheet LGD-01 for construction legend
  - See Sheet TS-43 for Safety Edge Details
  - \* Max rollover between shoulder and travel lane not to exceed 8%.
  - [A] Shoulder slope to rotate to full superelevation across the bridge over Line "PR-AELE"  
See Superelevation Diagrams
  - [B] Left shoulder width increased to 12'-4" approaching and exiting the bridge over Line "PR-AELE"

**NOTE TO REVIEWER**

2-foot lane extensions at the shoulders will be reviewed and implemented where applicable in a future submittal.

**FOR INFORMATION ONLY**

**DRAFT**  
 NOT FOR CONSTRUCTION

RECOMMENDED FOR APPROVAL _____	DESIGN ENGINEER _____	DATE _____
DESIGNED: _____ SGM _____	DRAWN: _____ CGR _____	
CHECKED: _____ ADR _____	CHECKED: _____ ADR _____	

INDIANA  
 DEPARTMENT OF TRANSPORTATION

I-64 EASTBOUND MAINLINE  
 PROPOSED TYPICAL SECTIONS

HORIZONTAL SCALE	BRIDGE FILE
3/16"=1'-0"	N/A
VERTICAL SCALE	DESIGNATION
N/A	1900162
SURVEY BOOK	SHEETS TS-04
ELECTRONIC	3 of 27
CONTRACT	PROJECT
R-42570	1900162

arcosmeyer 12/1/2022 10:42:47 AM model: TYP-04 [Sheet] file: p:\i-64\lakes\Documents\Indianapolis Projects\78704 INDOT-S I-64 ATL 00 CAD-ORD\Sheets\Roadway\1900162\_L\_S\_TYP02.dgn

12/11/2022; 12:18:55 PM  
 model: PLN-08 [Sheet]  
 file: p:\i\p\m\h\mb\org\PM\Great\_Lakes\Documents\Indianapolis Projects\78704 INDOT-S I-64 ATL\00 CAD-ORD\Sheets\Roadway\1900162\_S\_PLN01.dgn

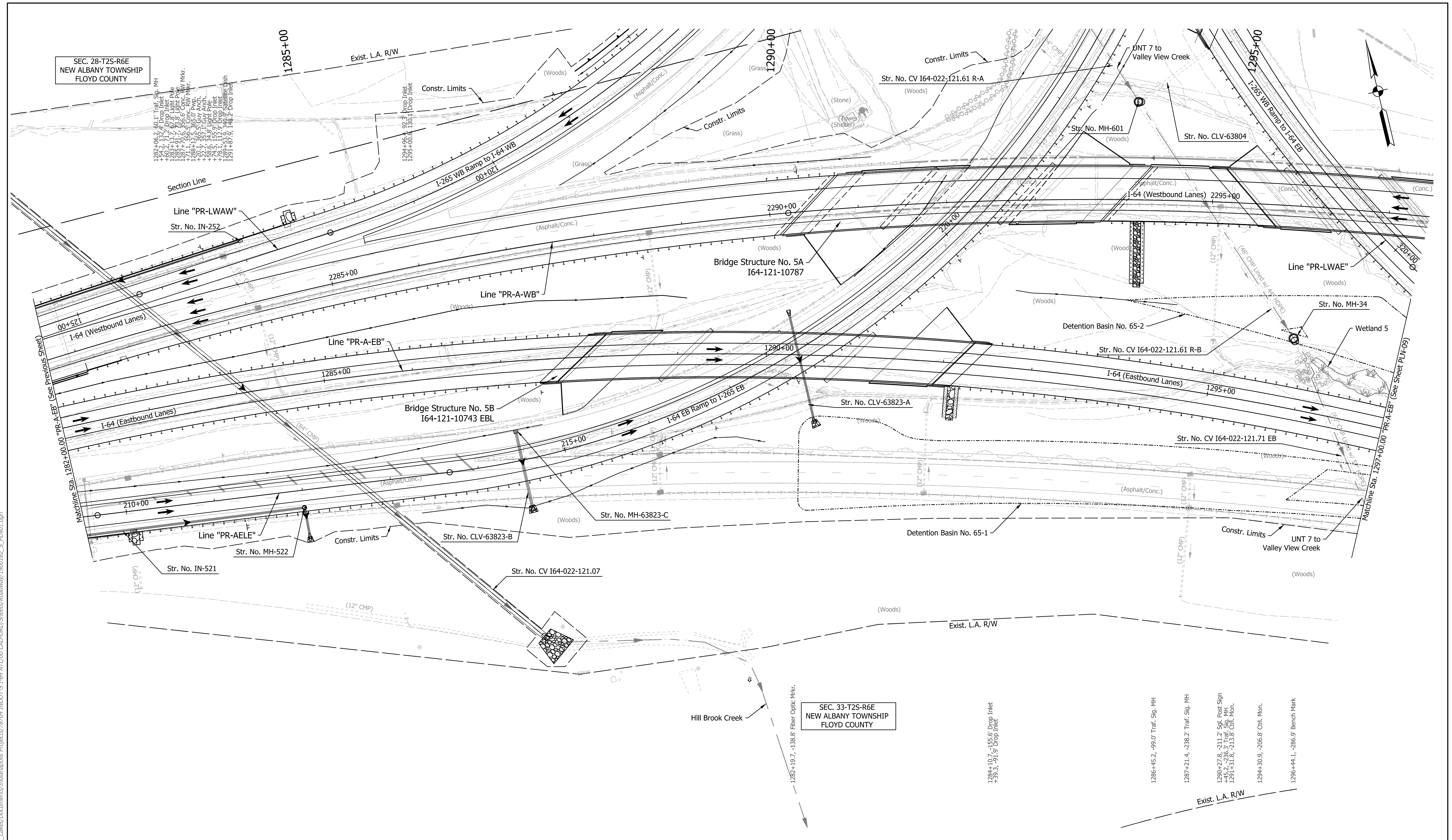

SEC. 28-T2S-R6E  
NEW ALBANY TOWNSHIP  
FLOYD COUNTY

SEC. 33-T2S-R6E  
NEW ALBANY TOWNSHIP  
FLOYD COUNTY

Note:  
For Geometric information see Geometric Layout Sheets  
GEO-01 to GEO-13.

FOR INFORMATION ONLY

**DRAFT**  
 NOT FOR CONSTRUCTION

RECOMMENDED FOR APPROVAL	DESIGN ENGINEER	DATE
DESIGNED: SGM	DRAWN: RJS	
CHECKED: KRC	CHECKED: KRC	

INDIANA  
 DEPARTMENT OF TRANSPORTATION  
  
 PLAN SHEET  
 LINE "PR-A-EB"  
 STA. 1282+00 TO STA. 1297+00

HORIZONTAL SCALE	BRIDGE FILE
1"=50'	N/A
VERTICAL SCALE	DESIGNATION
N/A	1900162
SURVEY BOOK	SHEETS
ELECTRONIC	4 of 27
CONTRACT	PROJECT
R-42570	1900162

12/11/2022; 12:34:09 PM  
 model: PLN-02 [Sheet]  
 file: p:\i\p\m\h\mb\org\PM\Great\_Lakes\Documents\Indianapolis Projects\78704 INDOT-S I-64 ATL 00 CAD-ORD\Sheets\Roadway\1900162\_S\_PLN1.Dgn

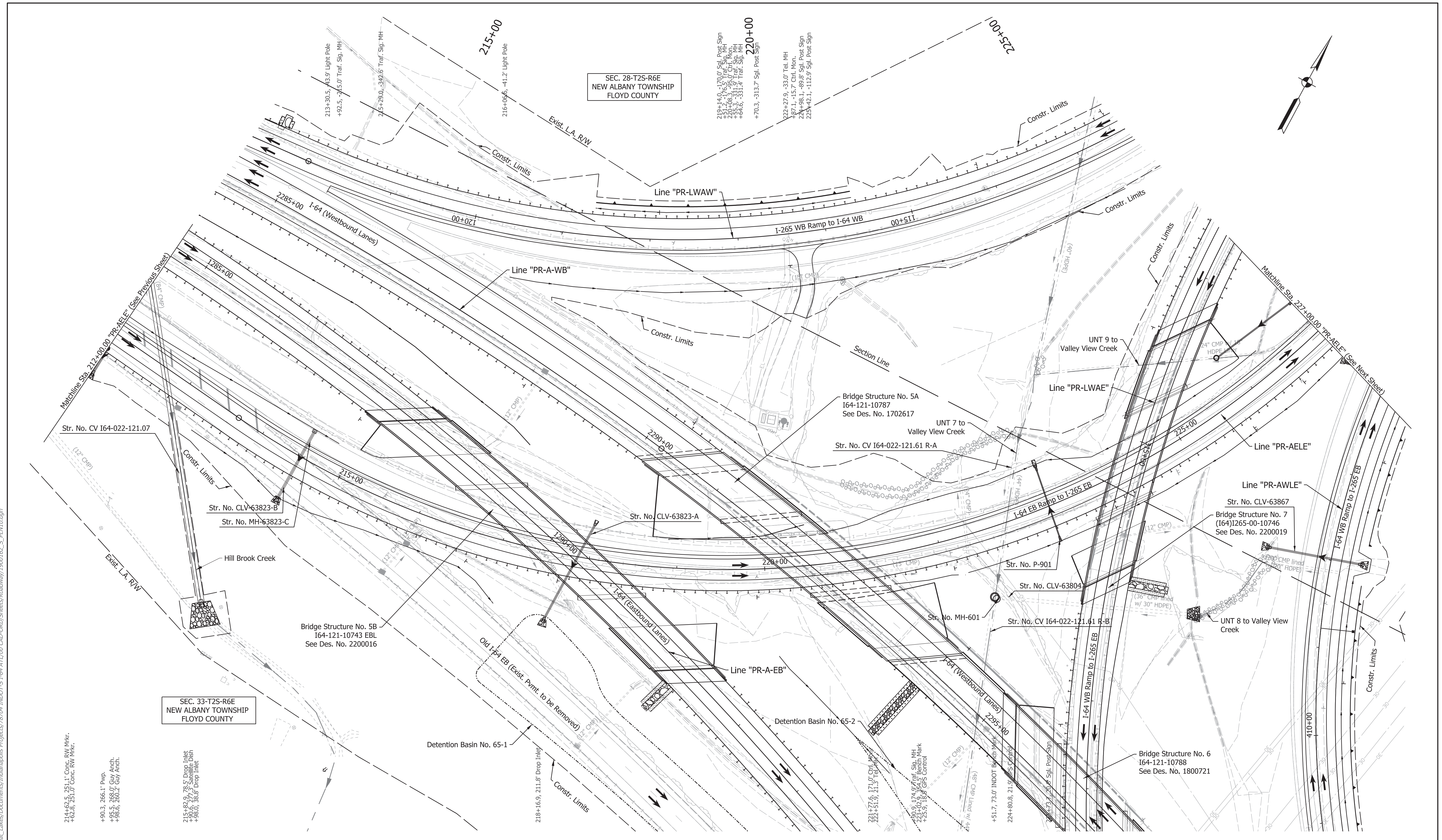

Note:  
 For Geometric information see Geometric Layout Sheets  
 GEO-01 to GEO-13.

FOR INFORMATION ONLY

DRAFT  
 NOT FOR CONSTRUCTION

RECOMMENDED FOR APPROVAL	DESIGN ENGINEER	DATE
DESIGNED: MDS	DRAWN: RJS	
CHECKED: KRC	CHECKED: KRC	

INDIANA  
 DEPARTMENT OF TRANSPORTATION  
  
 PLAN SHEET  
 LINE "PR-AELE"  
 STA. 212+00 TO STA. 227+00

HORIZONTAL SCALE	BRIDGE FILE	
1"=50'	N/A	
VERTICAL SCALE	DESIGNATION	
N/A	1900162	
SURVEY BOOK	SHEETS	PLN-55
ELECTRONIC	6 of	27
CONTRACT	PROJECT	
R-42570	1900162	



ssmith  
 12/5/2022 9:43:25 AM  
 model: PIN-01 [Sheet]  
 file: p:\p\pin-01\mb\org\PMGreat\_Lakes\Documents\Indianapolis Projects\78704 INDOT-S I-64 ATL 00 CAD-ORD\Sheets\Bridges\Bridge No. 5B - I-64 EB over EB to NB Ramp\1900162\_S\_LAYOUT.dgn

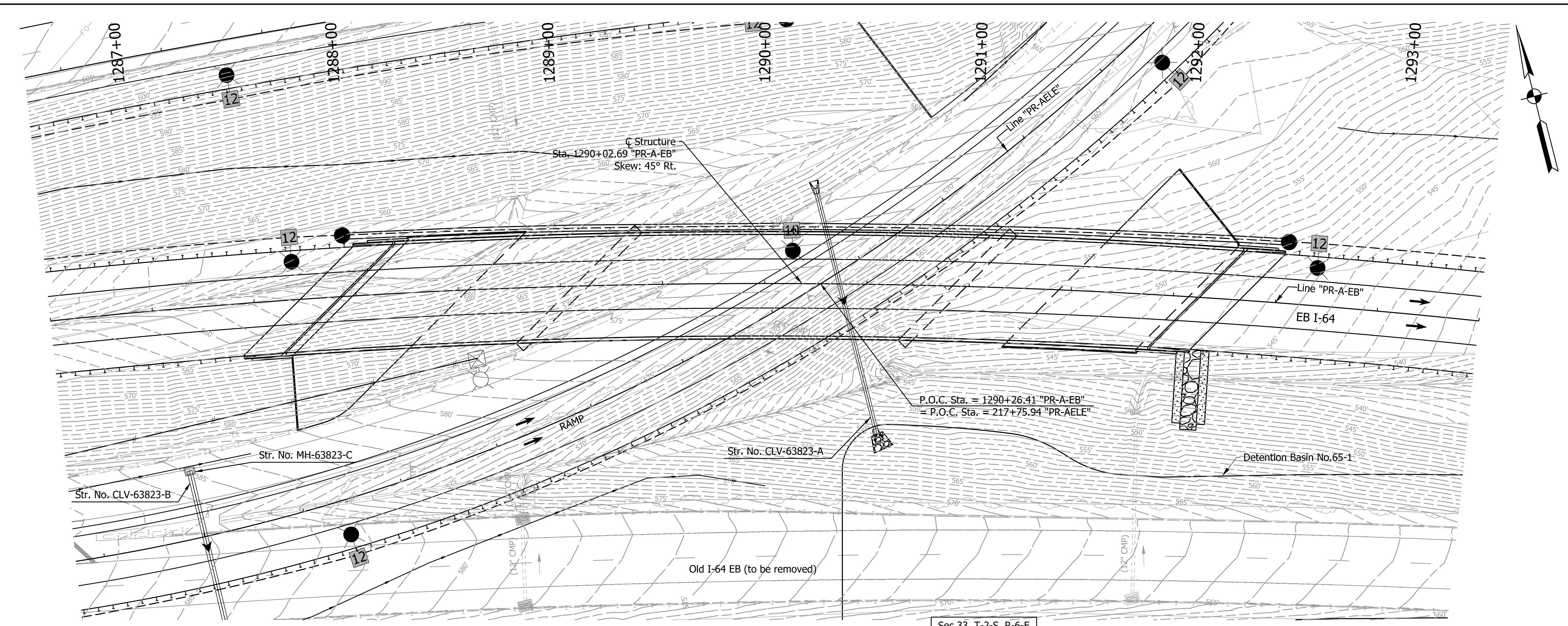

**EXISTING STRUCTURE**  
No Existing Structure

**EARTHWORK TABULATION**  
For Earthwork Summary, See Road Plans Des. No. 1900162

**HORIZONTAL CURVE DATA FOR LINE "PR-AE-L"**

CURVE 49  
 P.I. 224+00.52 "PR-AE-L"  
 $\Delta = 93^\circ 29' 31.14''$  LT.  
 $D = 05^\circ 53' 40.66''$   
 $R = 972'$   
 $T = 1033.12'$   
 $L = 1586.05'$   
 $E = 446.49'$   
 $e = 6.00\%$

**HORIZONTAL CURVE DATA FOR LINE "PR-A-EB"**

CURVE 6  
 P.I. 1289+64.30 "PR-A-EB"  
 $\Delta = 35^\circ 59' 02.09''$  RT.  
 $D = 01^\circ 43' 03.00''$   
 $R = 3336'$   
 $T = 1083.41'$   
 $L = 2095.13'$   
 $E = 171.52'$   
 $e = 5.00\%$

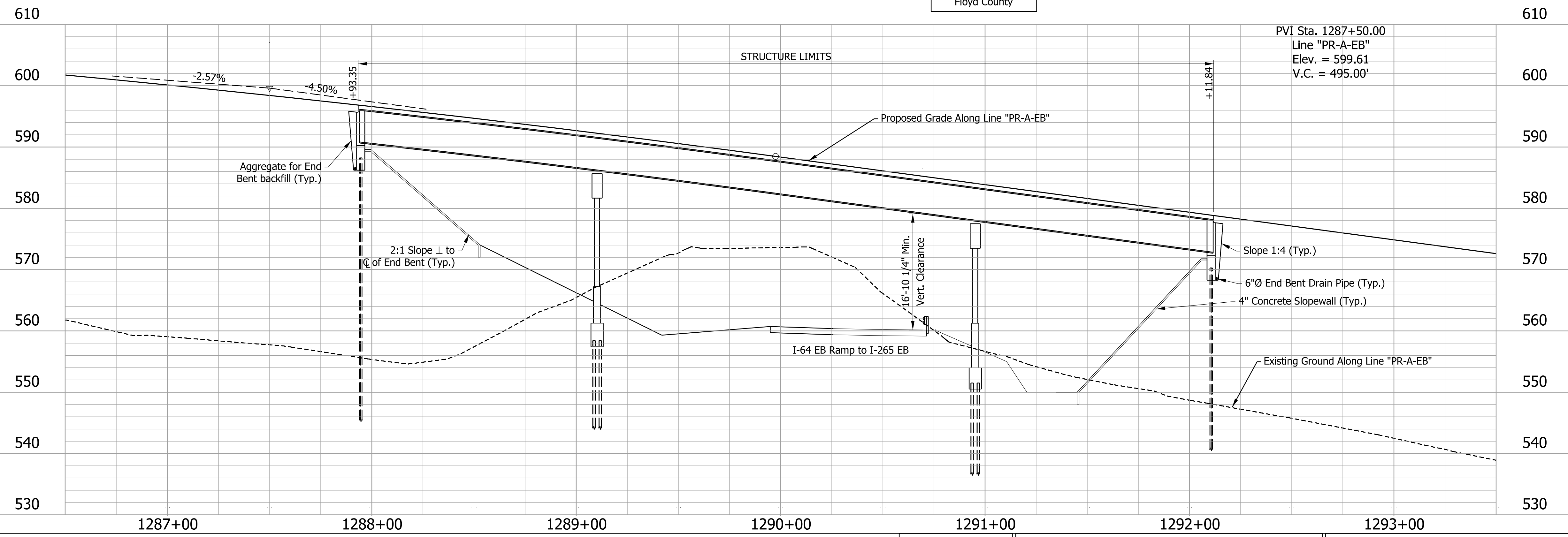

PVI Sta. 1287+50.00  
 Line "PR-A-EB"  
 Elev. = 599.61  
 V.C. = 495.00'

**NOTES:**  
 For Reference Ties and Benchmarks, See Road Plans Des. No. 1900162.  
 For Ditch Grades & Guardrail Limits, See Plan & Profile Sheet of Road Plans, Des. No. 1900162.  
 For existing and proposed utilities, drainage, lighting, signing, and ITS, see Des. No. 1900162.

**CONTINUOUS COMPOSITE STEEL PLATE GIRDER BRIDGE**  
 3 SPANS: 115'-0", 185'-0" & 115'-0"  
 49'-8" CLEAR ROADWAY SKEW: 45° RT.  
 I-64 EB OVER I-64 EB RAMP TO I-265 EB  
 FLOYD COUNTY

**DRAFT**  
NOT FOR CONSTRUCTION

RECOMMENDED FOR APPROVAL	DESIGN ENGINEER	DATE
DESIGNED: RTW	DRAWN: JP	
CHECKED: TSW	CHECKED: TSW	

INDIANA  
DEPARTMENT OF TRANSPORTATION

LAYOUT - LINE "PR-A-EB"

HORIZONTAL SCALE	BRIDGE FILE
1"=30'	164-121-10743 EBL
VERTICAL SCALE	DESIGNATION
1"=10'	2200016
DRAWING NUMBER	SHEETS
S1 of S4	11 of 27
CONTRACT	PROJECT
R-42570	1900162

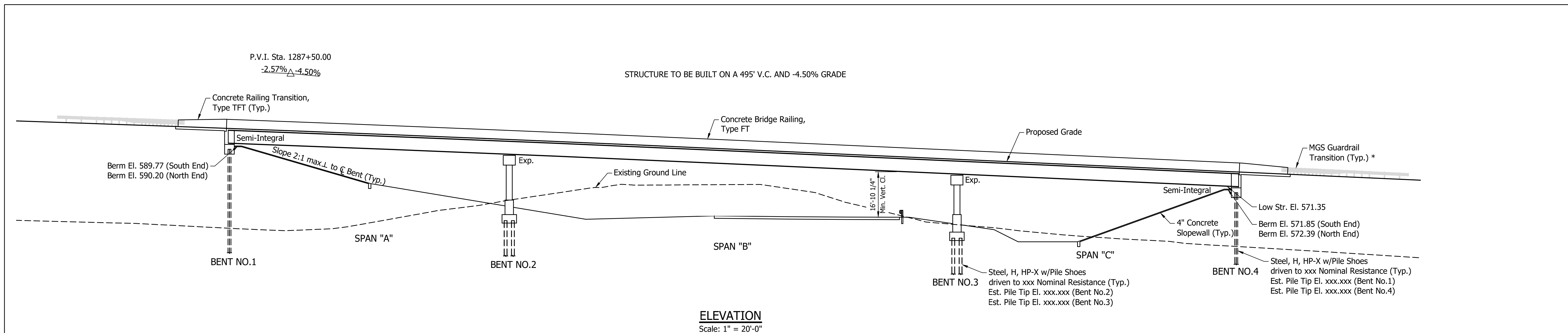

**Note to Reviewer:**

- Impact Attenuators are being evaluated for the proposed pier on the inside of the curve of the ramp alignment.
- The Geotechnical Investigation is currently underway. Soil borings, Pile Size and Type will be added at a future submittal.
- Discussions are ongoing regarding the use of squared or skewed RCBA's and Terminal Joint Type based on Optional Bid Pavement Sections. Details will be finalized for the Stage 3 submission.

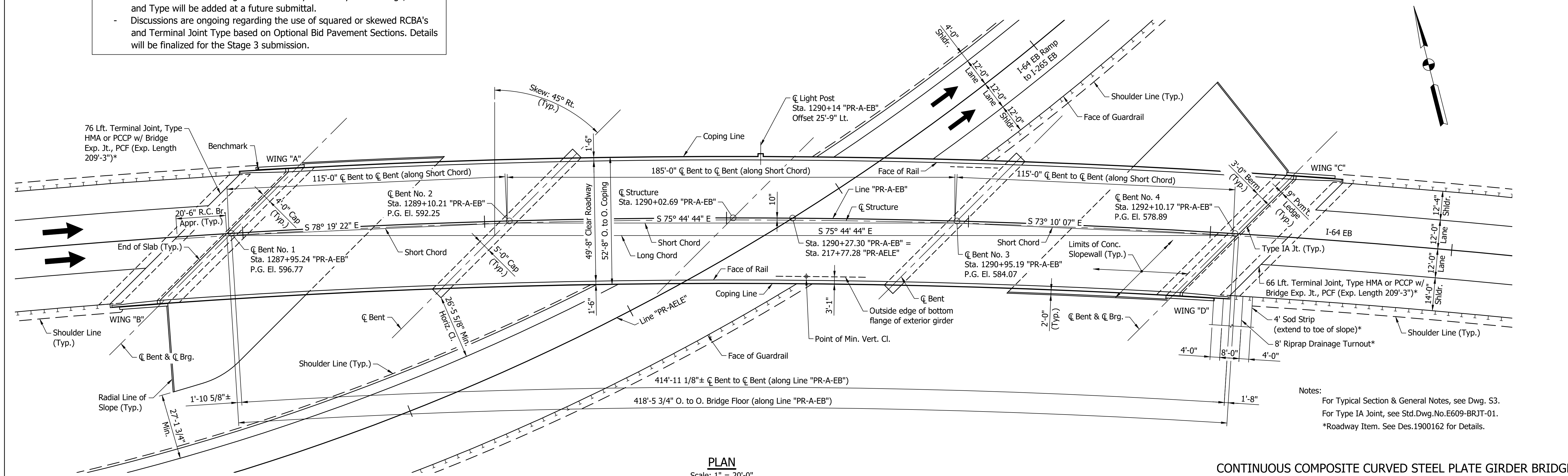

**CONTINUOUS COMPOSITE CURVED STEEL PLATE GIRDER BRIDGE**  
 3 SPANS: 115'-0", 185'-0" & 115'-0"  
 49'-8" CLEAR ROADWAY SKEW: 45° RT.  
 I-64 EB OVER I-64 EB RAMP TO I-265 EB  
 FLOYD COUNTY

Notes:  
 For Typical Section & General Notes, see Dwg. S3.  
 For Type IA Joint, see Std.Dwg.No.E609-BRJT-01.  
 \*Roadway Item. See Des.1900162 for Details.

DRAFT NOT FOR CONSTRUCTION	RECOMMENDED FOR APPROVAL _____	DESIGN ENGINEER _____ DATE _____	INDIANA DEPARTMENT OF TRANSPORTATION	HORIZONTAL SCALE AS NOTED	BRIDGE FILE I64-121-10743 EBL
	DESIGNED: RTW	DRAWN: JF		VERTICAL SCALE AS NOTED	DESIGNATION 2200016
	CHECKED: TSW	CHECKED: RTW		DRAWING NO. S2 of S4	SHEETS 12 of 27
	GENERAL PLAN			CONTRACT R-42570	PROJECT 1900162

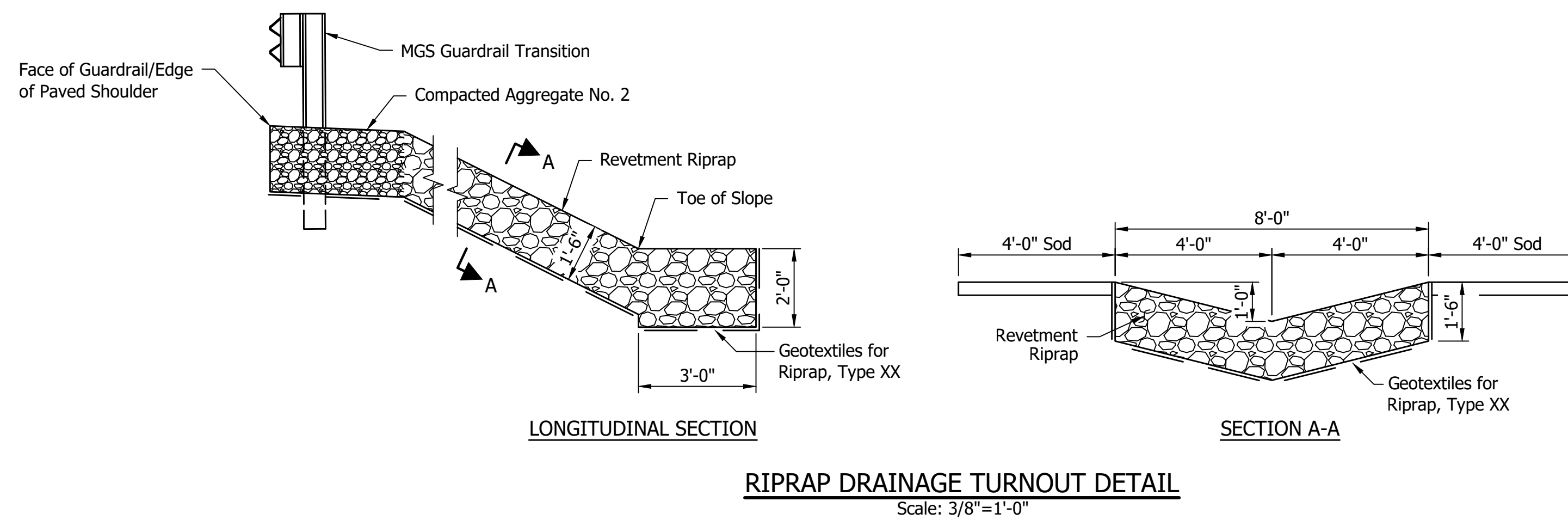
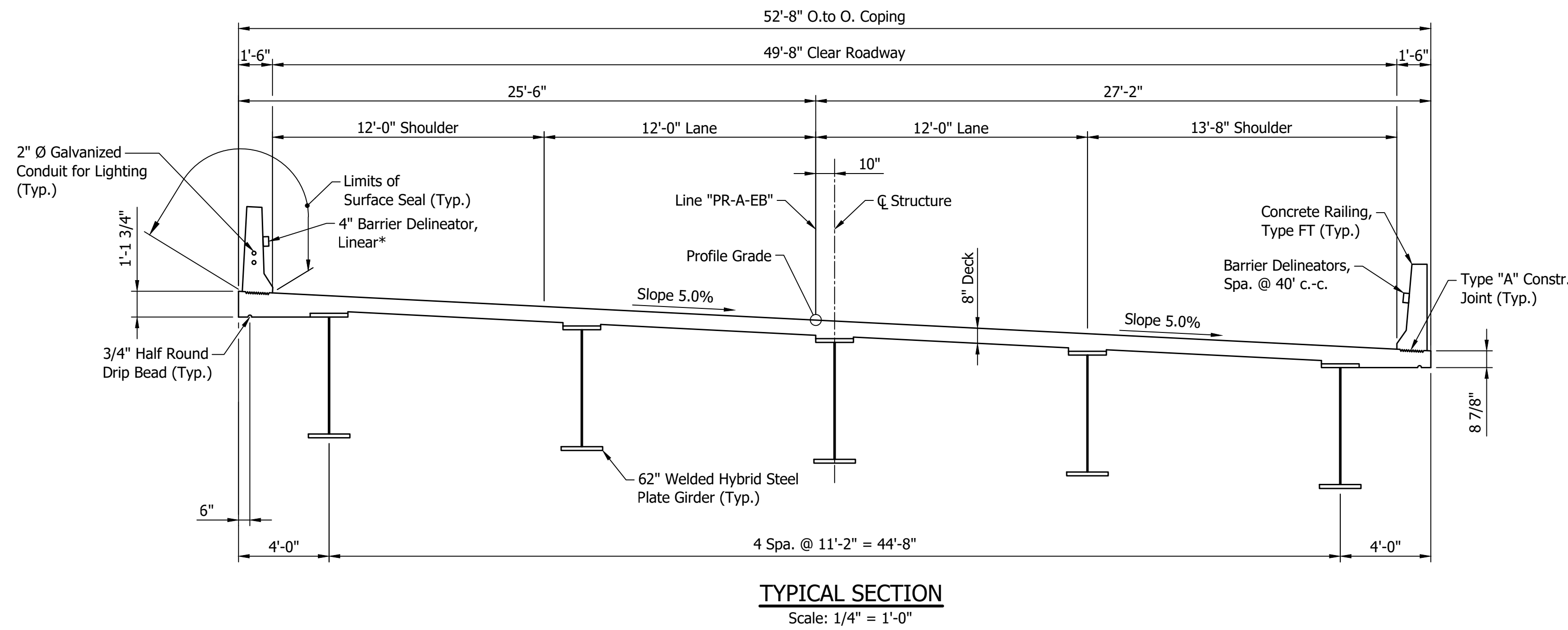

**Note to Reviewer:**

- Seismic Data will be provided at a later submittal when the Geotechnical Investigation is available.
- Geotextile Type to be provided when Geotechnical Report is complete
- Surface Seal Quantity to be provided at Stage 3

**Notes:**

- For Plan & Elevation, see Dwg. S2.
- For Type "A" Construction Joint, see Std.Dwg.No.E702-CJTA-01.
- Superstructure will be constructed entirely during Phase 3B and no phased construction or longitudinal construction joints will be permitted.
- \* See Special Provisions for Linear Barrier Delineator Requirements

**SEISMIC DATA**  
AASHTO Guide Design Specifications for LRFD Seismic Bridge Design  
Seismic Zone Category X  
S1 = X  
Site Class X  
Fv = X

**CONTINUOUS COMPOSITE CURVED STEEL PLATE GIRDER BRIDGE**  
3 SPANS: 115'-0", 185'-0" & 115'-0"  
49'-8" CLEAR ROADWAY SKEW: 45° RT.  
I-64 EB OVER I-64 EB RAMP TO I-265 EB  
FLOYD COUNTY

**GENERAL NOTES**

Reinforcing bar covering shall be 2 1/2" in top and 1" minimum in the bottom of the floor slab, 3" in footings except for bottom bars which shall be 4" and 2" in all other parts, unless otherwise noted.

Reinforcing bars in deck, barrier, end bent diaphragms and end bent caps shall be epoxy coated, unless otherwise noted.

All exposed faces of the concrete bridge railings, concrete railing transitions, wings and end bents to be sealed in accordance with Article 702.21 of the Specifications.  
(Estimated Quantity = XXXX Sft.)

**DESIGN DATA**

**LIVE LOAD**  
Designed for HL-93 loading, in accordance with the AASHTO LRFD Bridge Design Specifications, Ninth Edition, 2020.

**DEAD LOAD**  
Actual weight plus 35 psf (composite) for future wearing surface and 15 psf (non-composite) for permanent metal deck forms.

**FLOOR SLAB**  
Designed with 7 1/2" structural depth plus 1/2" sacrificial wearing surface.

**DESIGN STRENGTHS**  
To be in accordance with AASHTO LRFD Bridge Design Specifications, Ninth Edition, 2020.

**CONCRETE:**  
Class "A": f<sub>c</sub>=3,500 psi  
Class "B": f<sub>c</sub>=3,000 psi  
Class "C": f<sub>c</sub>=4,000 psi

**REINFORCING BARS:**  
Grade 60: F<sub>y</sub>=60,000 psi

**STRUCTURAL STEEL:**  
ASTM A709 Grade 50W: F<sub>y</sub>=50 ksi  
ASTM A709 Grade HPS 70W: F<sub>y</sub>=70 ksi

**CONSTRUCTION LOADING**

The exterior girders have been checked for strength, deflection, and overturning using the construction loads shown below. Cantilever overhang brackets were assumed for support of the deck overhang past the edge of exterior girder. The finishing machine was assumed to be supported 6 inches outside the vertical coping form. The top overhang brackets were assumed to be located 6 inches past the edge of the vertical coping form. The bottom overhang brackets were assumed to be braced against the intersection of the girder bottom flange and web. The Contractor shall use blocking or other methods to ensure beam rotation does not occur prior to or during concrete placement on exterior girders where diaphragm spacing exceeds 20 ft.

**DECK FALSEWORK LOADS:**  
Designed for 15 psf for permanent metal stay-in-place deck forms, removable deck forms, and 2-ft. exterior walkway.

**CONSTRUCTION LIVE LOAD:**  
Designed for 20 psf extending 2 ft. past the edge of coping and 75 plf vertical force applied at a distance of 6 inches outside the face of coping over a 30-ft. length of the deck centered with the finishing machine.

**FINISHING-MACHINE LOAD:**  
4,500 lbs distributed over 10 ft. along the coping.

**WIND LOAD:**  
Designed for 70 mph horizontal wind loading in according with AASHTO LRFD 3.8.1.

**DRAFT**  
NOT FOR CONSTRUCTION

RECOMMENDED FOR APPROVAL	DESIGN ENGINEER	DATE
DESIGNED: RTW	DRAWN: JF	
CHECKED: TSW	CHECKED: RTW	

INDIANA  
DEPARTMENT OF TRANSPORTATION

GENERAL PLAN  
TYPICAL SECTION

HORIZONTAL SCALE	BRIDGE FILE
AS NOTED	I64-121-10743 EBL
VERTICAL SCALE	DESIGNATION
AS NOTED	2200016
DRAWING NO.	SHEETS
S3 of S4	13 of 27
CONTRACT	PROJECT
R-42570	1900162

PROJECT	DESIGNATION
1900162	1800721
CONTRACT	BRIDGE FILE
R-42570	164-121-10788

# INDIANA DEPARTMENT OF TRANSPORTATION

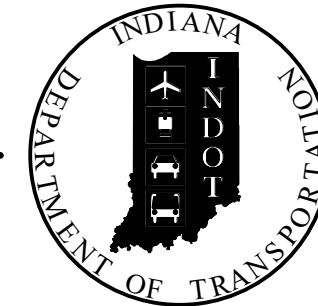

## BRIDGE PLANS

FOR SPANS OVER 20 FEET  
ROUTE: I-64 WB AT: RP 121+41

PROJECT NO. 1800721 P.E.  
1900162 R/W  
1800721 CONST.

Bridge Replacement on I-64 WB over I-265 WB to I-64 EB Ramp  
Located 2.20 Miles East of US 150 in  
Section 33, T-2-S, R-6-E, New Albany Township, Floyd County, Indiana

END CONSTRUCTION  
Sta.2077+97.42 Line "PR-L-EB"

BEGIN CONSTRUCTION  
Sta.1025+38.31 Line "PR-U-WB"

BEGIN PROJECT  
Sta.1180+86.02 Line "PR-A-EB"

STRUCTURE LOCATION  
Ç Str.-Sta.2296+73.13 "PR-A-WB"

END PROJECT  
Sta.1393+50.00 Line "PR-A-EB"

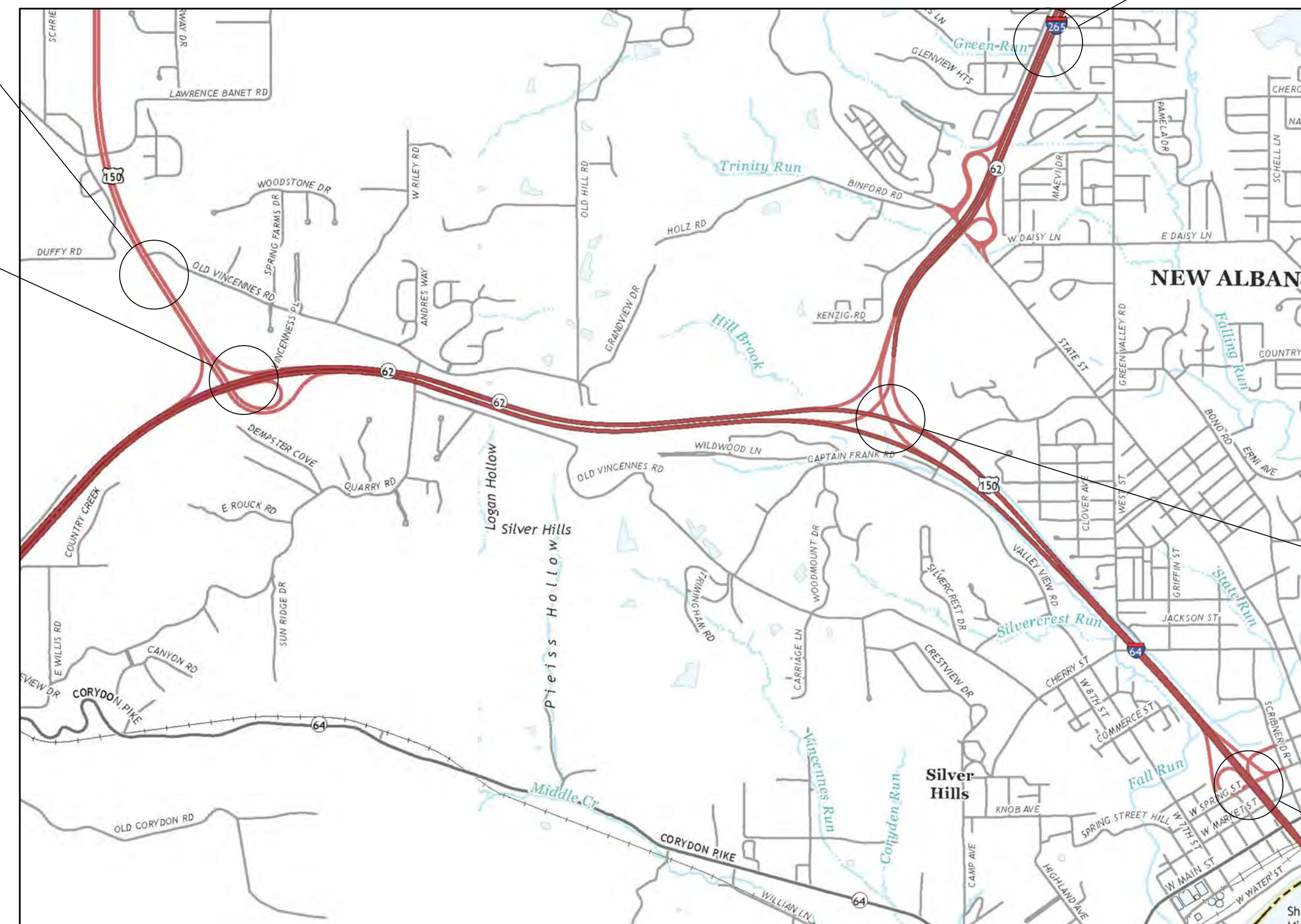

LOCATION MAP  
SCALE: 1" = 2000'

STRUCTURE INFORMATION				
STRUCTURE	TYPE	SPAN AND SKEW	OVER	STATION
164-121-10788	CONTINUOUS COMPOSITE CURVED STEEL PLATE GIRDER BRIDGE	3 SPANS: 67'-0", 108'-0", 67'-0" SKEW: 45° LT.	I-265 WB RAMP TO I-64 EB	Ç STRUCTURE STA.2296+73.13 "PR-A-WB"

DESIGNATION	PROJECT DESCRIPTION	
ROAD		
1900162	I-64 ATL (LEAD)	LEAD DES.
1900366	US 150 and Old Vincennes Road (East)	
2100019	I-64 Lighting US 150 to I-64 / I-265	
BRIDGE		
1800706	Bridge Painting on US 150 EB over I-64, Str.No. 150-22-04983 AEBL	STR. 1
1800405	Bridge Painting on US 150 EB over I-64, Str.No. 150-22-04983 AWBL	STR. 2
1700207	Bridge Replacement on I-64 EB over Quarry Road, Str.No. 164-120-10786	STR. 3
2200015	Bridge Replacement on I-64 WB over Quarry Road, Str.No. 164-120-10742	STR. 4
1702617	Bridge Replacement on I-64 WB over I-64 EB to I-265 EB Ramp, Str.No. 164-121-10787	STR. 5A
2200016	New Bridge on I-64 EB over I-64 EB Ramp to I-265 EB, Str.No.164-121-10743 EBL	STR. 5B
1800721	Bridge Replacement on I-64 WB over I-265 WB Ramp to I-64 EB, Str.No.164-121-10788	STR. 6
2200019	Bridge Replacement on I-265 WB to I-64 EB Ramp over I-64 EB to I-265 EB Ramp, Str.No.(164)265-00-10746	STR. 7
2200017	Bridge Replacement on I-64 EB over Captain Frank Road, Str.No.164-121-10744	STR. 8
2200018	Superstructure Replacement on I-64 WB over Captain Frank Road, Str. No. 164-121-04986 DWBL	STR. 9
1702614	Bridge Deck Overlay on I-64 over Cherry Street, Str.No. 164-122-04988 D	STR. 10
2000326 / 2000323	Bridge Deck Replacement & Widening on I-265 EB & Ramp Over State Street, Str.No. I265-00-05513 JCEB & DRCB	STR. 11
2000324	Bridge Deck Overlay on I-265 WB Over State Street, Str.No. I265-00-05513 DWBL	STR. 12
1700206	Bridge Deck Replacement I-64 EB over SR 62/ SR 64	STR. 13
1700205	Bridge Deck Replacement on I-64 WB over SR 62/ SR 64	STR. 14
2000144	Bridge Deck Overlay on I-64 EB over Yenowine Lane	STR. 15
2000145	Bridge Deck Overlay on I-64 WB over Yenowine Lane	STR. 16
2002072	US 150 EB over Little Indian Creek, Str.No.150-22-05230 CEB	STR. 18
2002073	US 150 WB over Little Indian Creek, Str.No.150-22-05230 CWB	STR. 19
2200719	I-64 EB & WB over SR 62 / Spring Street, Str.No.164-123-04689 C	STR. 20
2200718	I-64 WB Off-Ramp to Spring Street over I-64 WB On-Ramp from Spring Street, Str.No.164-123-04688 D	STR. 21
DRAINAGE		
TBD	US 150 Twin Arch Pipe Liner	STR. 17
TBD	Valley View Creek (6 Small Structures and 7 Small Pipe Replacements)	
TBD	Valley View Creek CMP Liner	
TBD	UNT to Little Indian Creek CMP Liner	
TBD	Hill Brook CMP Liner	
TBD	Small Pipes CMP Liners (2)	

Note to Reviewer:  
The list of Kinned Projects is tentative and subject to change at INDOT Seymour District's direction. This list represents the current understanding of the Contract Package

### STAGE 2 PLANS

PLANS PREPARED BY:

8320 CRAIG STREET | INDIANAPOLIS, IN 46250  
317.849.5832 | F. 317.841.4280 | WWW.B-L-N.COM

**DRAFT**  
NOT FOR CONSTRUCTION

PLANS PREPARED BY:	BEAM, LONGEST & NEFF, LLC	(317)849-5832 PHONE NUMBER
CERTIFIED BY:		DATE
APPROVED FOR LETTING:	INDIANA DEPARTMENT OF TRANSPORTATION	DATE

TRAFFIC DATA	I-64 WB MAINLINE	I-265 WB TO I-64 EB
A.A.D.T. (2019)	18,050 V.P.D.	15,110 V.P.D.
A.A.D.T. (2046)	24,500 V.P.D.	18,340 V.P.D.
D.H.V. (2046)	3,450 V.P.H.	1,900 V.P.H.
DIRECTIONAL DISTRIBUTION	100 %	100 %
TRUCKS	13 % A.A.D.T.	7 % A.A.D.T.
	5 % D.H.V.	3 % D.H.V.

DESIGN DATA		
DESIGN SPEED	70 M.P.H.	55 M.P.H.
PROJECT DESIGN CRITERIA	4R (FREEWAY)	4R (FREEWAY)
FUNCTIONAL CLASSIFICATION	PRINCIPAL ARTERIAL	RAMP
RURAL/URBAN	URBAN	URBAN
TERRAIN	ROLLING	ROLLING
ACCESS CONTROL	FULL	FULL

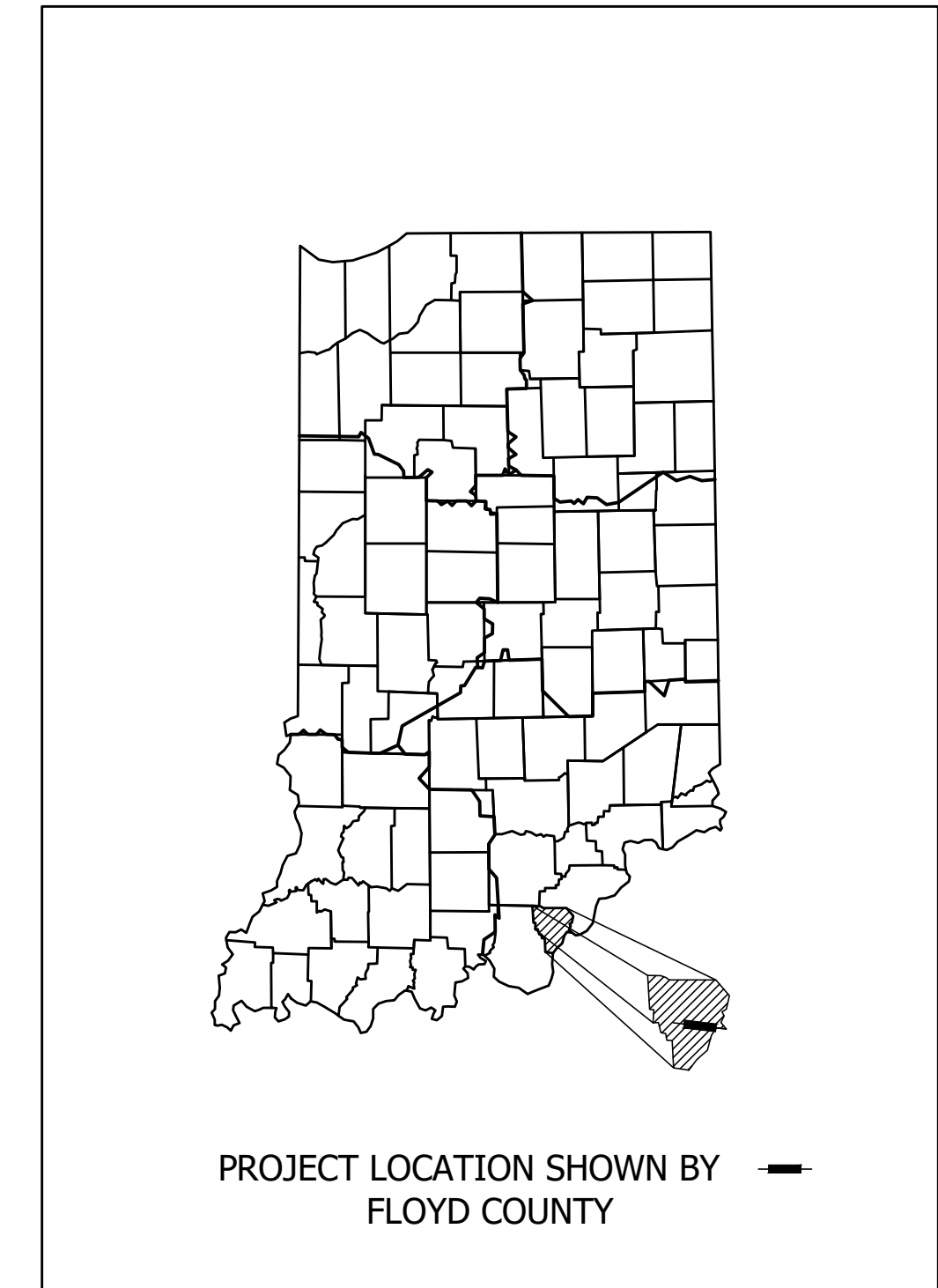

LATITUDE: 38°18'06.37" N LONGITUDE: 85°51'00.31" W

BRIDGE LENGTH: 0.047 MI.  
ROADWAY LENGTH: \* MI.  
TOTAL LENGTH: \* MI.  
MAX. GRADE: 3.05 %

\* SEE DES. NO. 1900162

HUC 12: 0514010110904  
HUC 14: 05140101150020

INDIANA DEPARTMENT OF TRANSPORTATION  
STANDARD SPECIFICATIONS DATED 2022  
TO BE USED WITH THESE PLANS.

BRIDGE FILE	
164-121-10788	
DESIGNATION	
1800721	
DRAWING NO.	SHEETS
	1 of 31
CONTRACT	PROJECT
R-42570	1900162

rstriegel  
 12/5/2022; 7:00:31 PM  
 model: TYP-13 [Sheet]  
 file: p:\i-64\mb\org\INDOT\Projects\8704 INDOT-S I-64 ATL\00 CAD-ORD\Sheets\Roadway\1900162\_S\_TYP02.dgn

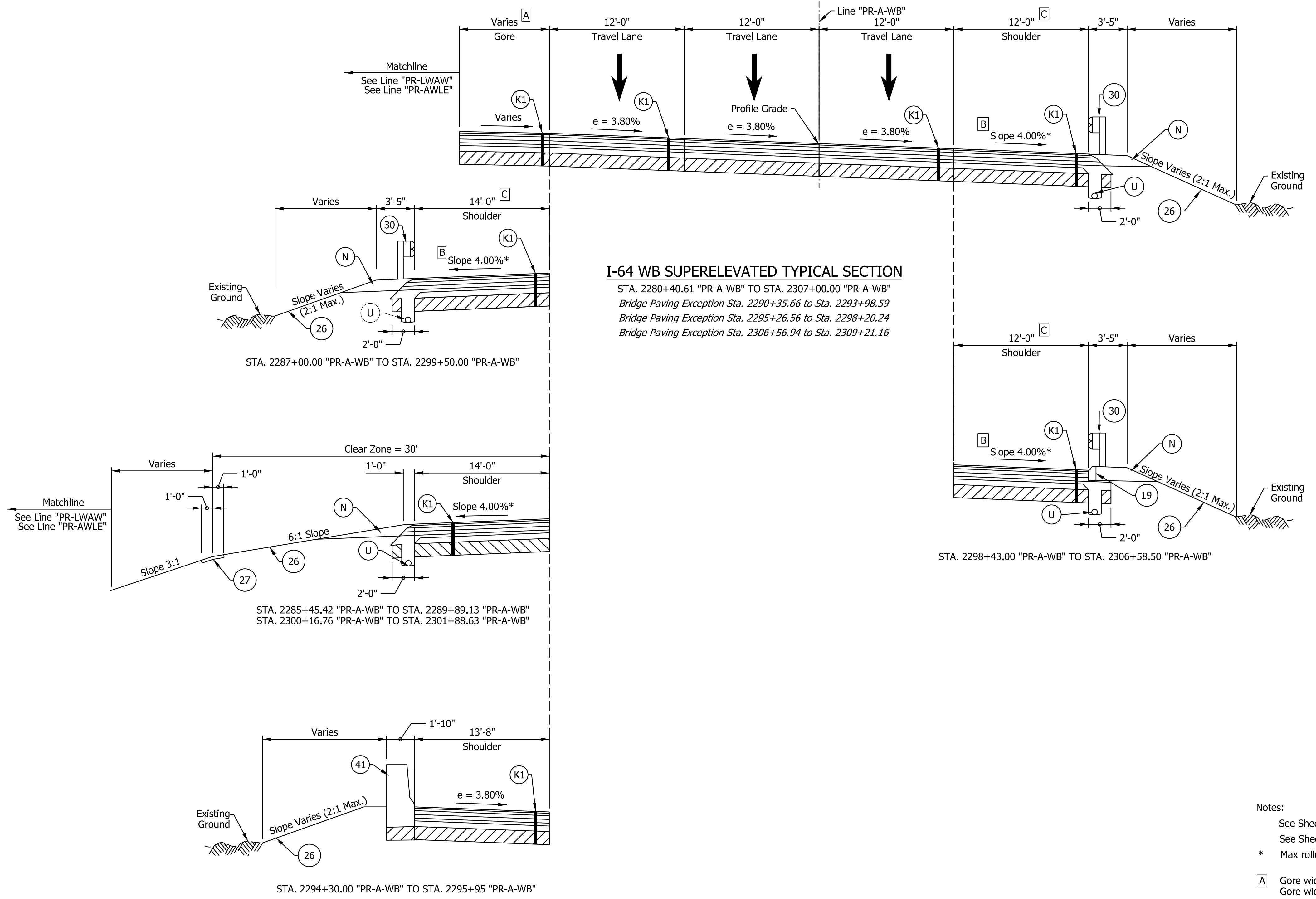

**I-64 WB SUPERELEVATED TYPICAL SECTION**  
 STA. 2280+40.61 "PR-A-WB" TO STA. 2307+00.00 "PR-A-WB"  
 Bridge Paving Exception Sta. 2290+35.66 to Sta. 2293+98.59  
 Bridge Paving Exception Sta. 2295+26.56 to Sta. 2298+20.24  
 Bridge Paving Exception Sta. 2306+56.94 to Sta. 2309+21.16

- Notes:
- See Sheet LGD-01 for construction legend
  - See Sheet TS-43 for Safety Edge Details
  - \* Max rollover between shoulder and travel lane not to exceed 8%.
  - A** Gore width varies from 0'-0" at Sta. 2280+40.61 to 25'-0" at Sta. 2285+45.42  
 Gore width varies from 30'-0" at Sta. 2301+88.63 to 0'-0" at Sta. 2306+96.82
  - B** Shoulder slope to rotate to match adjacent lane slope on the bridges over the interior system interchange ramps and Captain Frank Road.
  - C** Right shoulder width shall be 12'-4" from Sta. 2290+12.15 to Sta. 2298+43.00

**NOTE TO REVIEWER**  
 Coordination with Geotech is in progress.  
 Retaining Wall Details will be  
 Refined in future Submittals

**NOTE TO REVIEWER**  
 2-foot lane extensions at the shoulders will be  
 reviewed and implemented where applicable  
 in a future submittal.

**FOR INFORMATION  
 ONLY**

**DRAFT**  
 NOT FOR CONSTRUCTION

RECOMMENDED FOR APPROVAL _____	DESIGN ENGINEER _____	DATE _____
DESIGNED: _____ SGM _____	DRAWN: _____ CGR _____	
CHECKED: _____ ADR _____	CHECKED: _____ ADR _____	

INDIANA  
 DEPARTMENT OF TRANSPORTATION

**I-64 WESTBOUND MAINLINE  
 PROPOSED TYPICAL SECTIONS**

HORIZONTAL SCALE	BRIDGE FILE
3/16"=1'-0"	N/A
VERTICAL SCALE	DESIGNATION
N/A	1900162
SURVEY BOOK	SHEETS
ELECTRONIC	3 of 31
CONTRACT	PROJECT
R-42570	1900162

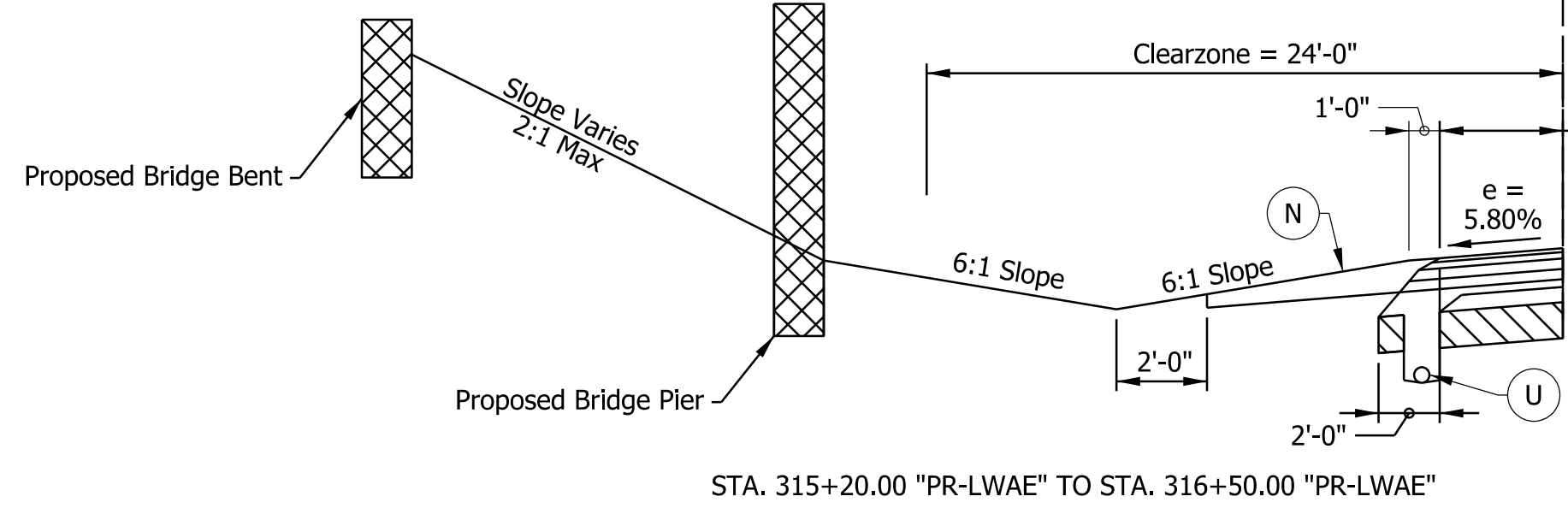
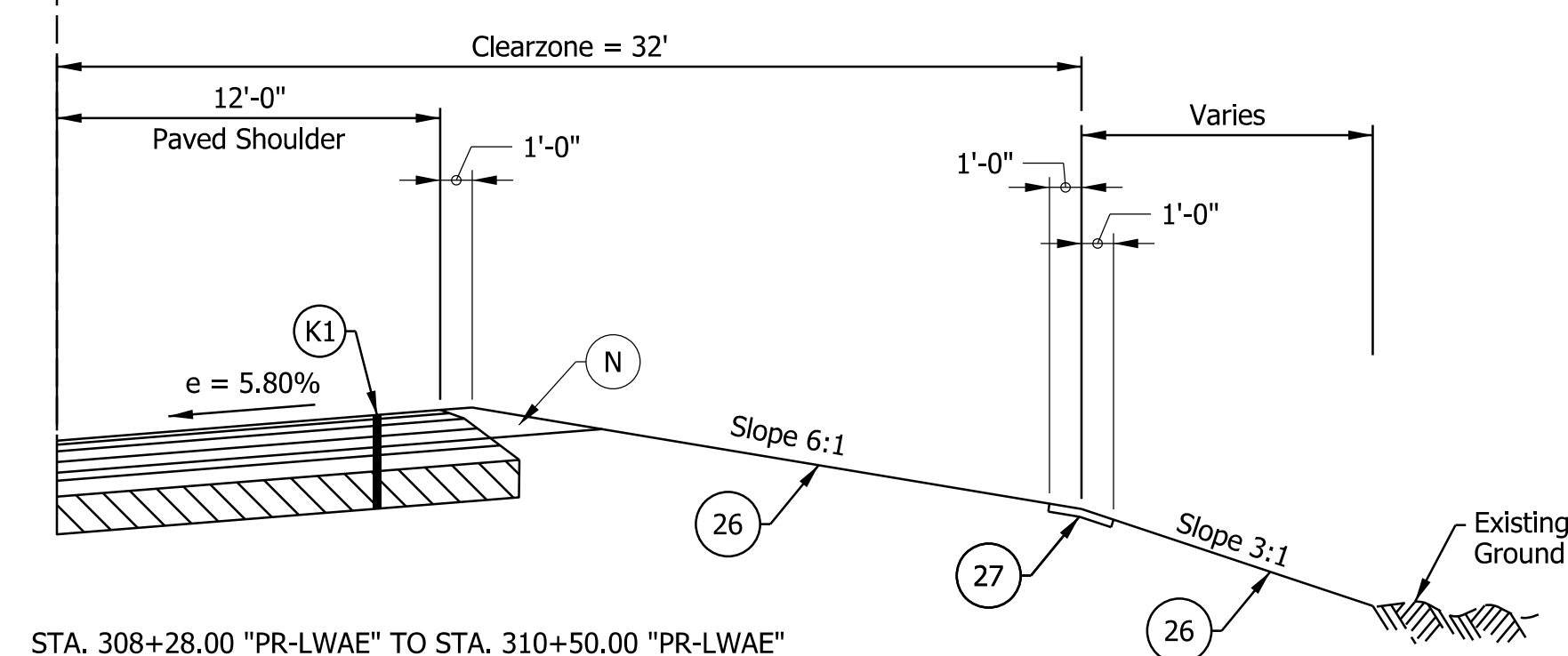
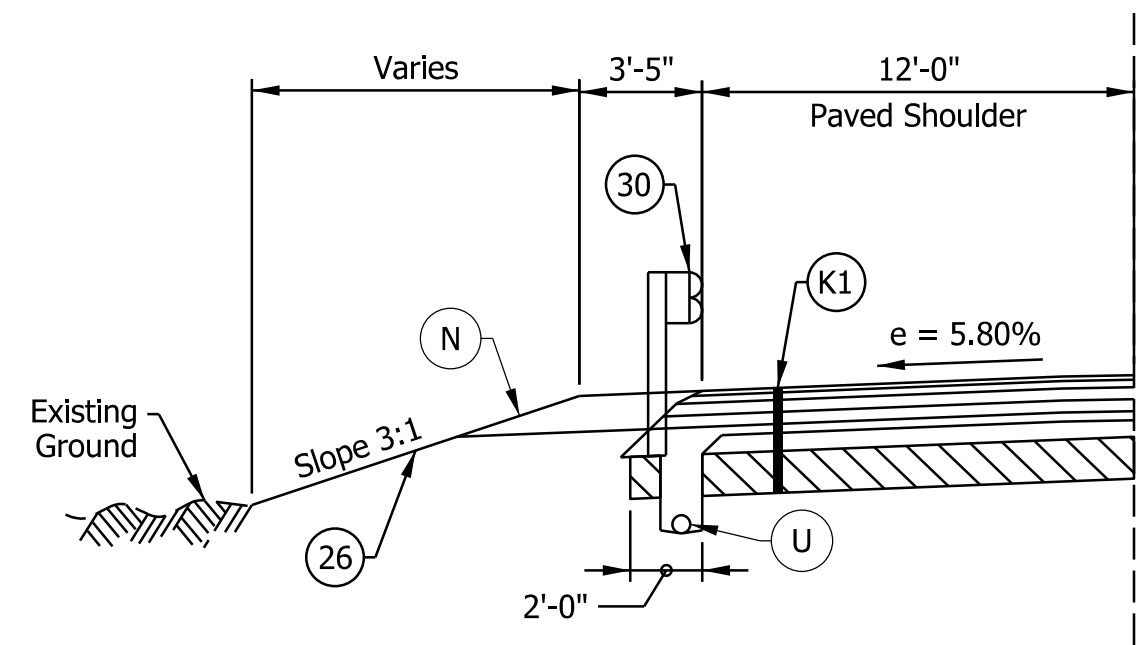
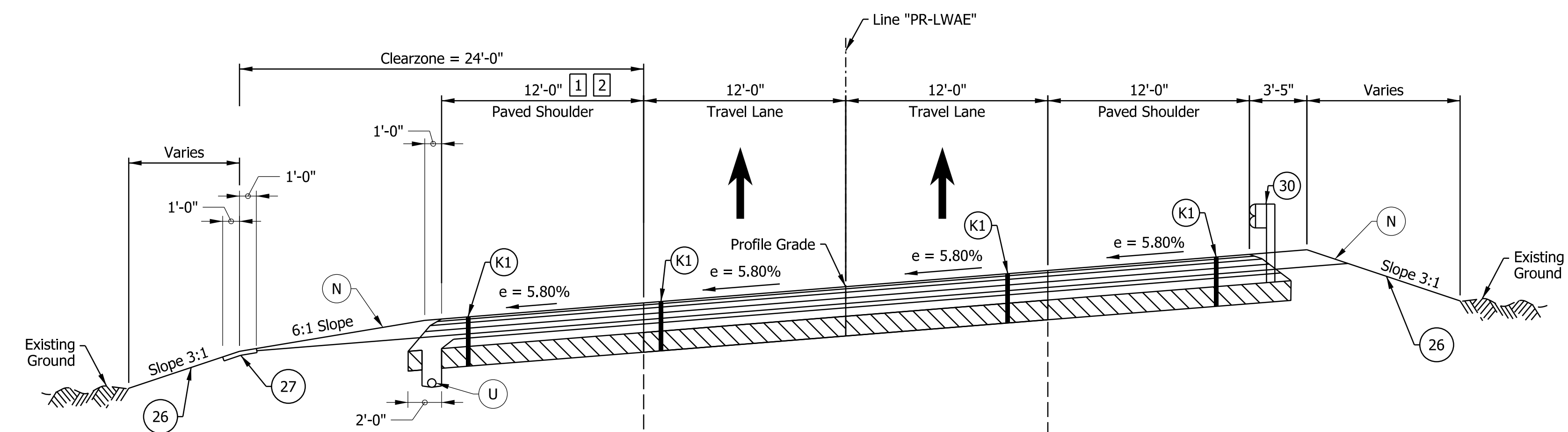
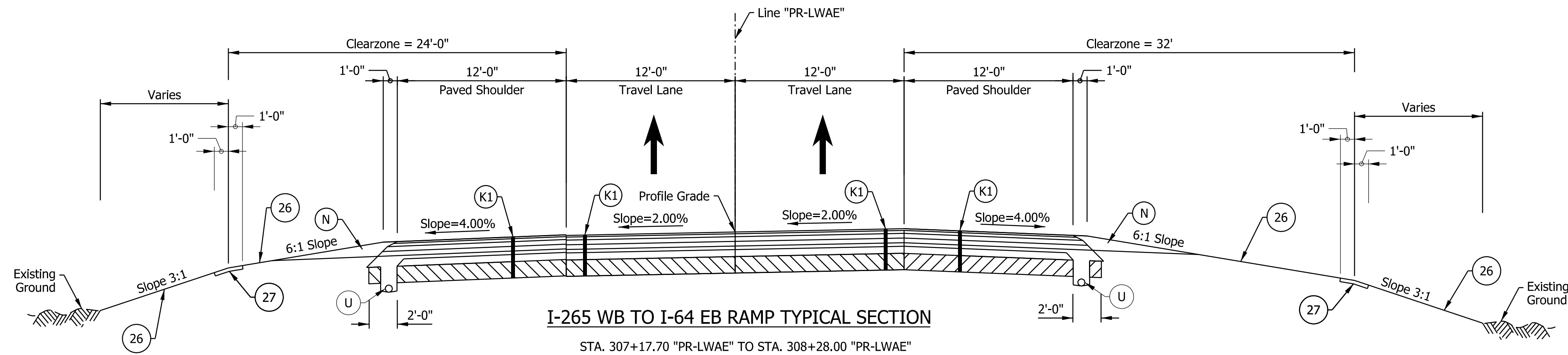

- Notes:
- See Sheet LGD-01 for construction legend
  - See Sheet TS-43 for Safety Edge Details
  - 1 Paved Shoulder width varies from 12'-0" at Sta. 313+00.00 to 12'-4" at 313+15.00  
Paved shoulder width varies from 12'-4" at 316+70.00 to 12'-0" at 316+85.00
  - 2 Paved Shoulder width varies from 12'-0" at Sta. 317+00.00 to 6'-0" at Sta. 319+00.00  
Paved Shoulder width is 6'-0" from Sta. 319+00.00 to 329+86.38

**NOTE TO REVIEWER**  
Locations and details for underdrain trenches and pipes will be reviewed further for the next submittal.

**NOTE TO REVIEWER**  
Refer to bridge plans for additional information related to slope paving adjacent to piers/bents

**FOR INFORMATION ONLY**

**DRAFT**  
NOT FOR CONSTRUCTION

RECOMMENDED FOR APPROVAL _____	DESIGN ENGINEER _____	DATE _____
DESIGNED: _____ DFK _____	DRAWN: _____ JKH _____	
CHECKED: _____ ADR _____	CHECKED: _____ ADR _____	

INDIANA DEPARTMENT OF TRANSPORTATION  
I-64 / I-265 INTERCHANGE RAMPS PROPOSED TYPICAL SECTIONS

HORIZONTAL SCALE	BRIDGE FILE
3/16"=1'-0"	N/A
VERTICAL SCALE	DESIGNATION
N/A	1900162
SURVEY BOOK	SHEETS TS-36
ELECTRONIC	4 of 31
CONTRACT	PROJECT
R-42570	1900162

rstriegel  
 12/5/2022; 7:01:42 PM  
 model: TYP-10 [Sheet]  
 file: p:\i-64\I-64\I-265\I-64\INDOT-S I-64 ATL\00 CAD-ORD\Sheets\Roadway\1900162\_L\_S\_TYP06.dgn



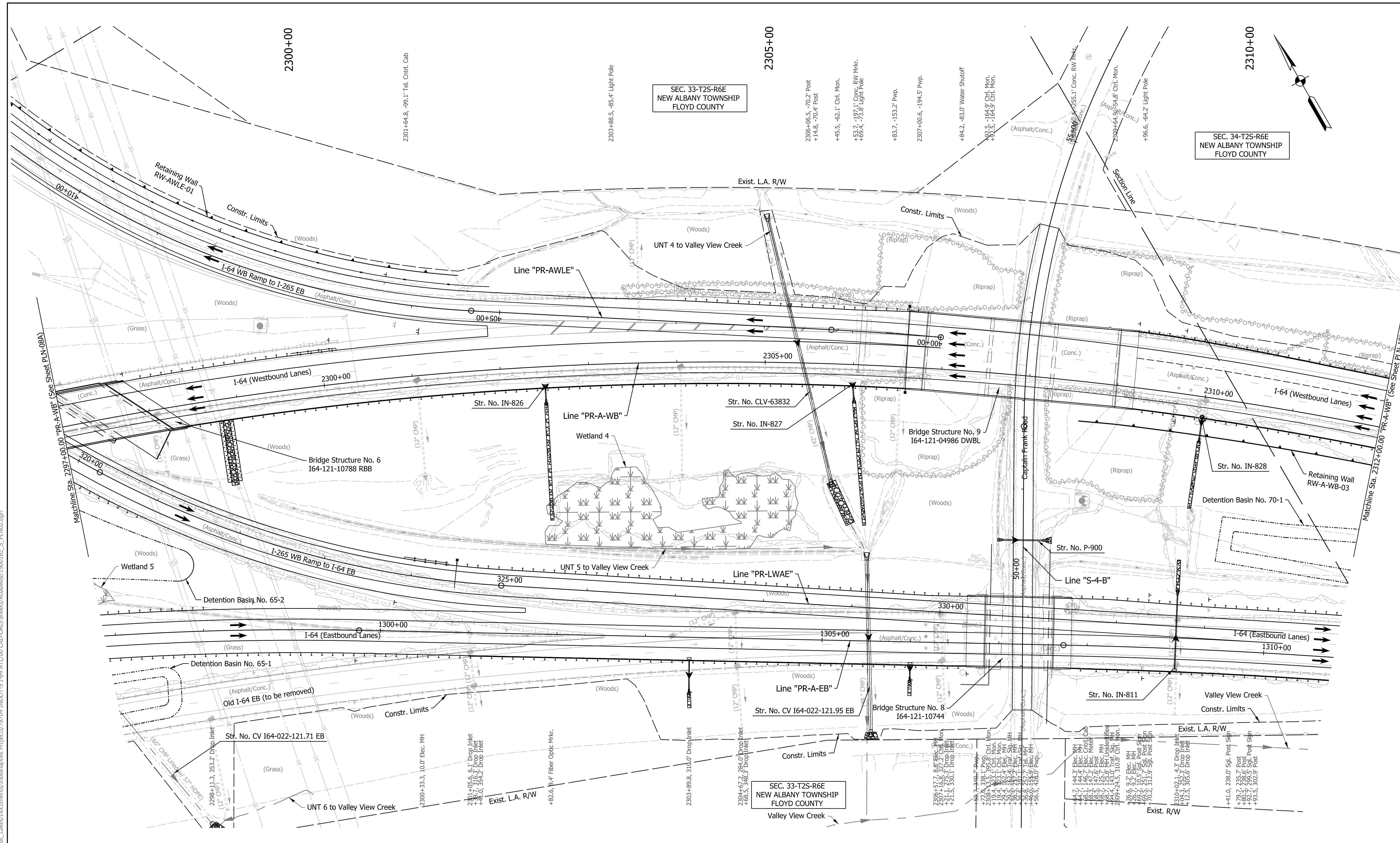

SEC. 33-T2S-R6E  
NEW ALBANY TOWNSHIP  
FLOYD COUNTY

SEC. 34-T2S-R6E  
NEW ALBANY TOWNSHIP  
FLOYD COUNTY

SEC. 33-T2S-R6E  
NEW ALBANY TOWNSHIP  
FLOYD COUNTY

SEC. 33-T2S-R6E  
NEW ALBANY TOWNSHIP  
FLOYD COUNTY

Note:  
For Geometric information see Geometric Layout Sheets  
GEO-01 to GEO-13.

**FOR INFORMATION ONLY**

**DRAFT**  
NOT FOR CONSTRUCTION

RECOMMENDED FOR APPROVAL	DESIGN ENGINEER	DATE
DESIGNED: SGM	DRAWN: RJS	
CHECKED: KRC	CHECKED: KRC	

INDIANA  
DEPARTMENT OF TRANSPORTATION

PLAN SHEET  
LINE "PR-A-WB"  
STA. 2297+00 TO STA. 2312+00

HORIZONTAL SCALE	BRIDGE FILE
1"=50'	N/A
VERTICAL SCALE	DESIGNATION
N/A	1900162
SURVEY BOOK	SHEETS
ELECTRONIC	7 of 31
CONTRACT	PROJECT
R-42570	1900162

I:\work\2022\7-21-19 PM 12-05-2022\7-21-19 PM model-PLAN-09 [Sheet].dwg  
 I:\work\2022\7-21-19 PM 12-05-2022\7-21-19 PM model-PLAN-09 [Sheet].dwg  
 I:\work\2022\7-21-19 PM 12-05-2022\7-21-19 PM model-PLAN-09 [Sheet].dwg





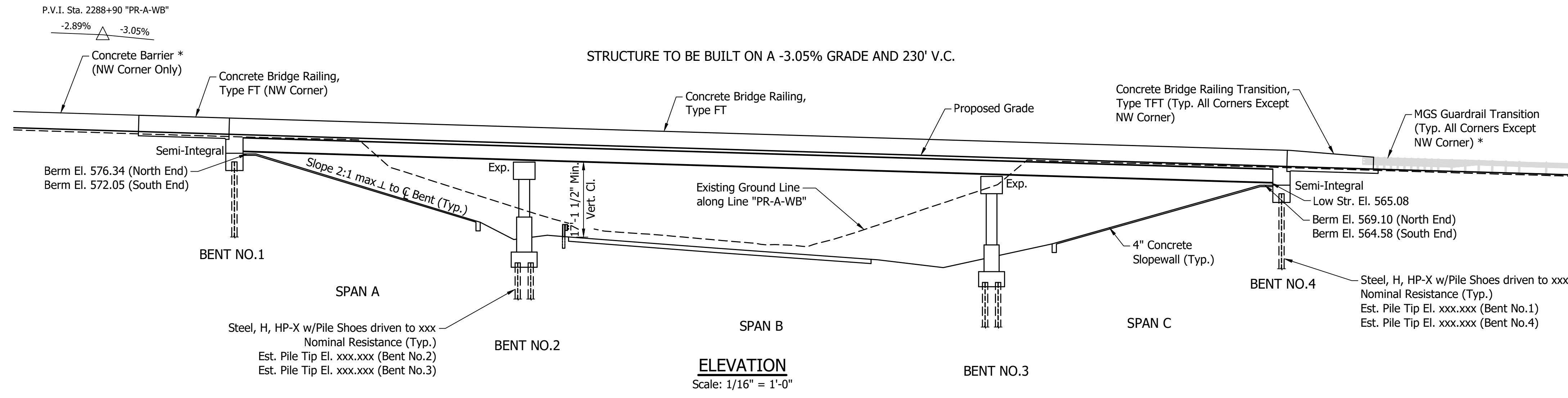

**Note to Reviewer:**

- Impact Attenuators are being evaluated for the proposed pier on the inside of the curve of the ramp alignment.
- The Geotechnical Investigation is currently underway. Soil borings, Pile Size and Type will be added at a future submittal.
- Discussions are ongoing regarding the use of squared or skewed RCBA's and Terminal Joint Type based on Optional Bid Pavement Sections. Details will be finalized for the Stage 3 submission.

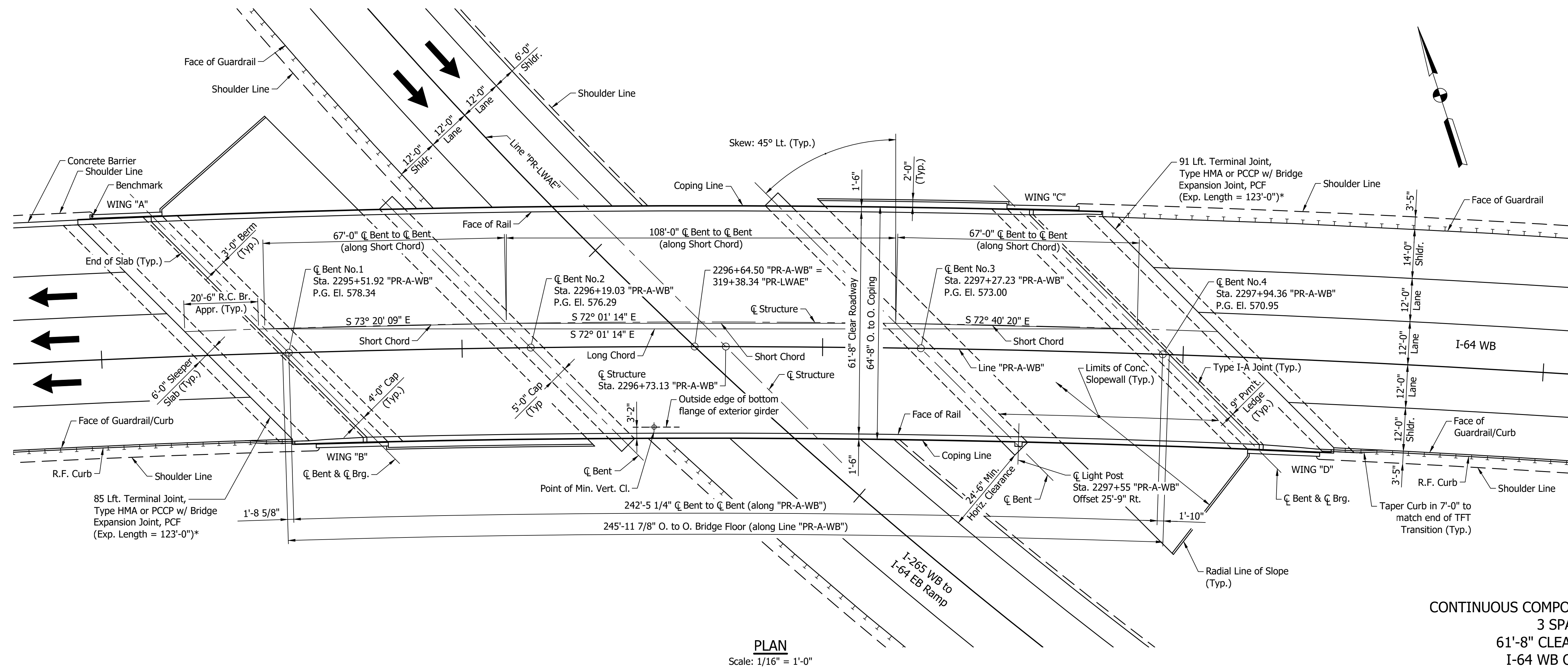

**Notes:**

- For Typical Section & General Notes, see Dwg. S4.
- For Type IA Joint, see Std. Dwg. No. E609-BRJT-01.
- \* Roadway Item. See Des. No. 1900162 for Details.

**CONTINUOUS COMPOSITE CURVED STEEL PLATE GIRDER BRIDGE**  
3 SPANS: 67'-0", 108'-0" & 67'-0"  
61'-8" CLEAR ROADWAY SKEW: 45° LT.  
I-64 WB OVER I-265 WB TO I-64 EB RAMP  
FLOYD COUNTY

**DRAFT**  
NOT FOR CONSTRUCTION

RECOMMENDED FOR APPROVAL	DESIGN ENGINEER	DATE
DESIGNED: TSW	DRAWN: JF	
CHECKED: AJC	CHECKED: AJC	

**INDIANA DEPARTMENT OF TRANSPORTATION**

**GENERAL PLAN**

HORIZONTAL SCALE	BRIDGE FILE
AS NOTED	164-121-10788
VERTICAL SCALE	DESIGNATION
AS NOTED	1800721
DRAWING NO.	SHEETS
S2 of S5	15 of 31
CONTRACT	PROJECT
R-42570	1900162

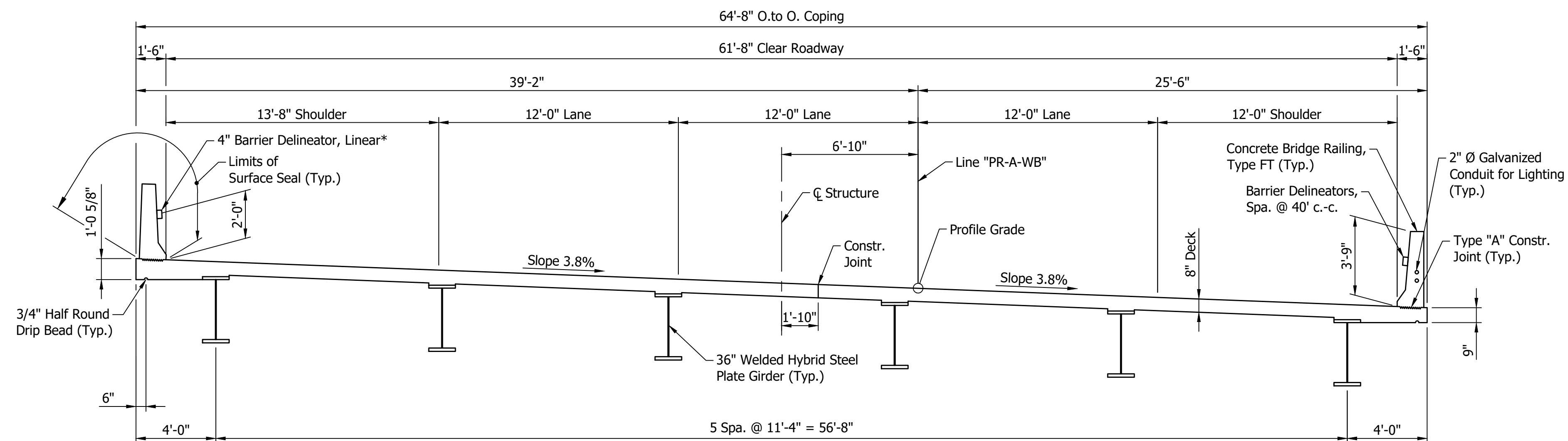

**TYPICAL SECTION**  
Scale: 1/4" = 1'-0"

**Note to Reviewer:**

- Seismic Data will be provided at a later submittal when the Geotechnical Investigation is available.
- Surface Seal Quantity to be provided at Stage 3

**GENERAL NOTES**

Reinforcing bar covering shall be 2 1/2" in top and 1" minimum in the bottom of the floor slab, 3" in footings except for bottom bars which shall be 4" and 2" in all other parts, unless otherwise noted.

Reinforcing bars in deck, barrier, end bent diaphragms and end bent caps shall be epoxy coated, unless otherwise noted.

All exposed faces of the concrete bridge railings, concrete railing transitions, wings and end bents to be sealed in accordance with Article 702.21 of the Specifications. (Estimated Quantity = XXXX Sft.)

Concrete in deck and Semi-integral end bents to be Class "C".

**DESIGN DATA**

**LIVE LOAD**  
Designed for HL-93 loading, in accordance with the AASHTO LRFD Bridge Design Specifications, Ninth Edition, 2020.

**DEAD LOAD**  
Actual weight plus 35 psf (composite) for future wearing surface and 15 psf (non-composite) for permanent metal deck forms.

**FLOOR SLAB**  
Designed with 7 1/2" structural depth plus 1/2" sacrificial wearing surface.

**DESIGN STRENGTHS**  
To be in accordance with AASHTO LRFD Bridge Design Specifications, Ninth Edition, 2020.

- CONCRETE:**
- Class "A":  $f_c=3,500$  psi
  - Class "B":  $f_c=3,000$  psi
  - Class "C":  $f_c=4,000$  psi
- REINFORCING BARS:**
- Grade 60:  $F_y=60,000$  psi
- STRUCTURAL STEEL:**
- ASTM A709 Grade 50W:  $F_y=50$  ksi
  - ASTM A709 Grade HPS 70W:  $F_y=70$  ksi

**CONSTRUCTION LOADING**

The exterior girders have been checked for strength, deflection, and overturning using the construction loads shown below. Cantilever overhang brackets were assumed for support of the deck overhang past the edge of exterior girder. The finishing machine was assumed to be supported 6 inches outside the vertical coping form. The top overhang brackets were assumed to be located 6 inches past the edge of the vertical coping form. The bottom overhang brackets were assumed to be braced against the intersection of the girder bottom flange and web. The Contractor shall use blocking or other methods to ensure girder rotation does not occur prior to or during concrete placement on exterior girders where diaphragm spacing exceeds 20 ft.

**DECK FALSEWORK LOADS:**  
Designed for 15 psf for permanent metal stay-in-place deck forms, removable deck forms, and 2-ft. exterior walkway.

**CONSTRUCTION LIVE LOAD:**  
Designed for 20 psf extending 2 ft. past the edge of coping and 75 plf vertical force applied at a distance of 6 inches outside the face of coping over a 30-ft. length of the deck centered with the finishing machine.

**FINISHING-MACHINE LOAD:**  
4,500 lbs distributed over 10 ft. along the coping.

**WIND LOAD:**  
Designed for 70 mph horizontal wind loading in according with AASHTO LRFD 3.8.1.

**SEISMIC DATA**

AASHTO Guide Design Specifications for LRFD Seismic Bridge Design

Seismic Zone Category X

S1 = X

Site Class X

Fv = X

**CONTINUOUS COMPOSITE CURVED STEEL PLATE GIRDER BRIDGE**  
3 SPANS: 67'-0", 108'-0" & 67'-0"  
61'-8" CLEAR ROADWAY SKEW: 45° LT.  
I-64 WB OVER I-265 WB TO I-64 EB RAMP  
FLOYD COUNTY

Notes:  
For Plan & Elevation, see Dwg. S2.  
For Type "A" Construction Joint, see Std.Dwg.No.E702-CJTA-01.  
\* See Special Provisions for Linear Barrier Delineator Requirements

**DRAFT**  
NOT FOR CONSTRUCTION

RECOMMENDED FOR APPROVAL	DESIGN ENGINEER	DATE
DESIGNED: TSW	DRAWN: JF	
CHECKED: AJC	CHECKED: AJC	

INDIANA  
DEPARTMENT OF TRANSPORTATION

GENERAL PLAN  
TYPICAL SECTION

HORIZONTAL SCALE	BRIDGE FILE
AS NOTED	164-121-10788
VERTICAL SCALE	DESIGNATION
AS NOTED	1800721
DRAWING NO.	SHEETS
S3 of S5	16 of 31
CONTRACT	PROJECT
R-42570	1900162

PROJECT	DESIGNATION
1900162	2200019
CONTRACT	BRIDGE FILE
R-42570	(164)1265-00-10746

STRUCTURE INFORMATION				
STRUCTURE	TYPE	SPAN AND SKEW	OVER	STATION
(164)1265-00-10746	CONTINUOUS COMPOSITE CURVED STEEL PLATE GIRDER	3 SPANS: 79'-0", 126'-0" & 79'-0" SKEW: 42° LT.	I-64 EB TO I-265 EB RAMP	Ç STRUCTURE STA. 315+12.84 "PR-LWAE"

# INDIANA DEPARTMENT OF TRANSPORTATION

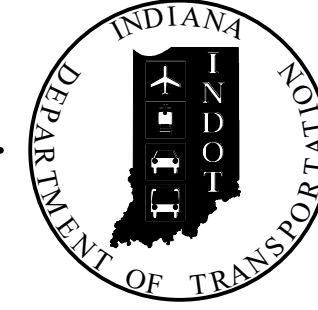

## BRIDGE PLANS

FOR SPANS OVER 20 FEET

ROUTE: I-265 WB TO I-64 EB RAMP AT: RP 0+27

PROJECT NO. 2200019 P.E.  
1900162 R/W  
2200019 CONST.

Bridge Replacement on I-265 WB to I-64 EB Ramp over I-64 EB to I-265 EB Ramp  
Located 0.25 Miles East of I-64 in  
Sections 28 & 33, T-2-S, R-6-E, New Albany Township, Floyd County, Indiana

DESIGNATION	PROJECT DESCRIPTION	
ROAD		
1900162	I-64 ATL	LEAD DES.
1900366	US 150 and Old Vincennes Road (East)	
2100019	I-64 Lighting US 150 to I-64 / I-265	
BRIDGE		
1800706	Bridge Painting on US 150 EB over I-64, Str.No. 150-22-04983 AEBL	STR. 1
1800405	Bridge Painting on US 150 EB over I-64, Str.No. 150-22-04983 AWBL	STR. 2
1700207	Bridge Replacement on I-64 EB over Quarry Road, Str.No. 164-120-10786	STR. 3
2200015	Bridge Replacement on I-64 WB over Quarry Road, Str.No. 164-120-10742	STR. 4
1702617	Bridge Replacement on I-64 WB over I-64 EB to I-265 EB Ramp, Str.No. 164-121-10787	STR. 5A
2200016	New Bridge on I-64 EB over I-64 EB Ramp to I-265 EB, Str.No.164-121-10743 EBL	STR. 5B
1800721	Bridge Replacement on I-64 WB over I-265 WB Ramp to I-64 EB, Str.No.164-121-10788	STR. 6
2200019	Bridge Replacement on I-265 WB to I-64 EB Ramp over I-64 EB to I-265 EB Ramp, Str.No.(164)1265-00-10746	STR. 7
2200017	Bridge Replacement on I-64 EB over Captain Frank Road, Str.No.164-121-10744	STR. 8
2200018	Superstructure Replacement on I-64 WB over Captain Frank Road, Str. No. 164-121-04986 DWBL	STR. 9
1702614	Bridge Deck Overlay on I-64 over Cherry Street, Str.No. 164-122-04988 D	STR. 10
2000326 / 2000323	Bridge Deck Replacement & Widening on I-265 EB & Ramp Over State Street, Str.No. 1265-00-05513 JCEB & DRCB	STR. 11
2000324	Bridge Deck Overlay on I-265 WB Over State Street, Str.No. 1265-00-05513 DWBL	STR. 12
1700206	Bridge Deck Replacement I-64 EB over SR 62/ SR 64	STR. 13
1700205	Bridge Deck Replacement on I-64 WB over SR 62/ SR 64	STR. 14
2000144	Bridge Deck Overlay on I-64 EB over Yenowine Lane	STR. 15
2000145	Bridge Deck Overlay on I-64 WB over Yenowine Lane	STR. 16
2002072	US 150 EB over Little Indian Creek, Str.No.150-22-05230 CEB	STR. 18
2002073	US 150 WB over Little Indian Creek, Str.No.150-22-05230 CWB	STR. 19
2200719	I-64 EB & WB over SR 62 / Spring Street, Str.No.164-123-04689 C	STR. 20
2200718	I-64 WB Off-Ramp to Spring Street over I-64 WB On-Ramp from Spring Street, Str.No.164-123-04688 D	STR. 21
DRAINAGE		
TBD	US 150 Twin Arch Pipe Liner	STR. 17
TBD	Valley View Creek (6 Small Structures and 7 Small Pipe Replacements)	
TBD	Valley View Creek CMP Liner	
TBD	UNT to Little Indian Creek CMP Liner	
TBD	Hill Brook CMP Liner	
TBD	Small Pipes CMP Liners (2)	

**Note to Reviewer:**  
The list of Kinned Projects is tentative and subject to change at INDOT Seymour District's direction. This list represents the current understanding of the Contract Package

### STAGE 2 PLANS

PLANS PREPARED BY:

8320 CRAIG STREET | INDIANAPOLIS, IN 46250  
317.849.5832 | F. 317.841.4280 | WWW.B-L-N.COM

**DRAFT**  
NOT FOR CONSTRUCTION

PLANS PREPARED BY:	BEAM, LONGEST & NEFF, LLC	(317)849-5832 PHONE NUMBER
CERTIFIED BY:	_____	DATE
APPROVED FOR LETTING:	_____	DATE
INDIANA DEPARTMENT OF TRANSPORTATION		

TRAFFIC DATA	I-265 WB TO I-64 EB RAMP	I-64 EB TO I-265 EB RAMP
	A.A.D.T. (2019)	15,110 V.P.D.
A.A.D.T. (2046)	18,340 V.P.D.	22,650 V.P.D.
D.H.V. (2046)	1,900 V.P.H.	1,290 V.P.H.
DIRECTIONAL DISTRIBUTION	100 %	100 %
TRUCKS	7 % A.A.D.T. 3 % D.H.V.	8 % A.A.D.T. 9 % D.H.V.

DESIGN DATA	55 M.P.H.	55 M.P.H.
	DESIGN SPEED	RECONSTRUCTION (FREEWAY)
PROJECT DESIGN CRITERIA	RAMP	RAMP
FUNCTIONAL CLASSIFICATION	URBAN	URBAN
TERRAIN	ROLLING	ROLLING
ACCESS CONTROL	FULL	FULL

PROJECT LOCATION SHOWN BY  
FLOYD COUNTY

LATITUDE: 38°18'9.50" N LONGITUDE: 85°51'1.87" W

BRIDGE LENGTH: 0.054 MI.  
ROADWAY LENGTH: \* MI.  
TOTAL LENGTH: \* MI.  
MAX. GRADE: 5.00 %  
\* SEE DES. NO. 1900162

HUC 12: 051401010904  
HUC 14: 05140101150020

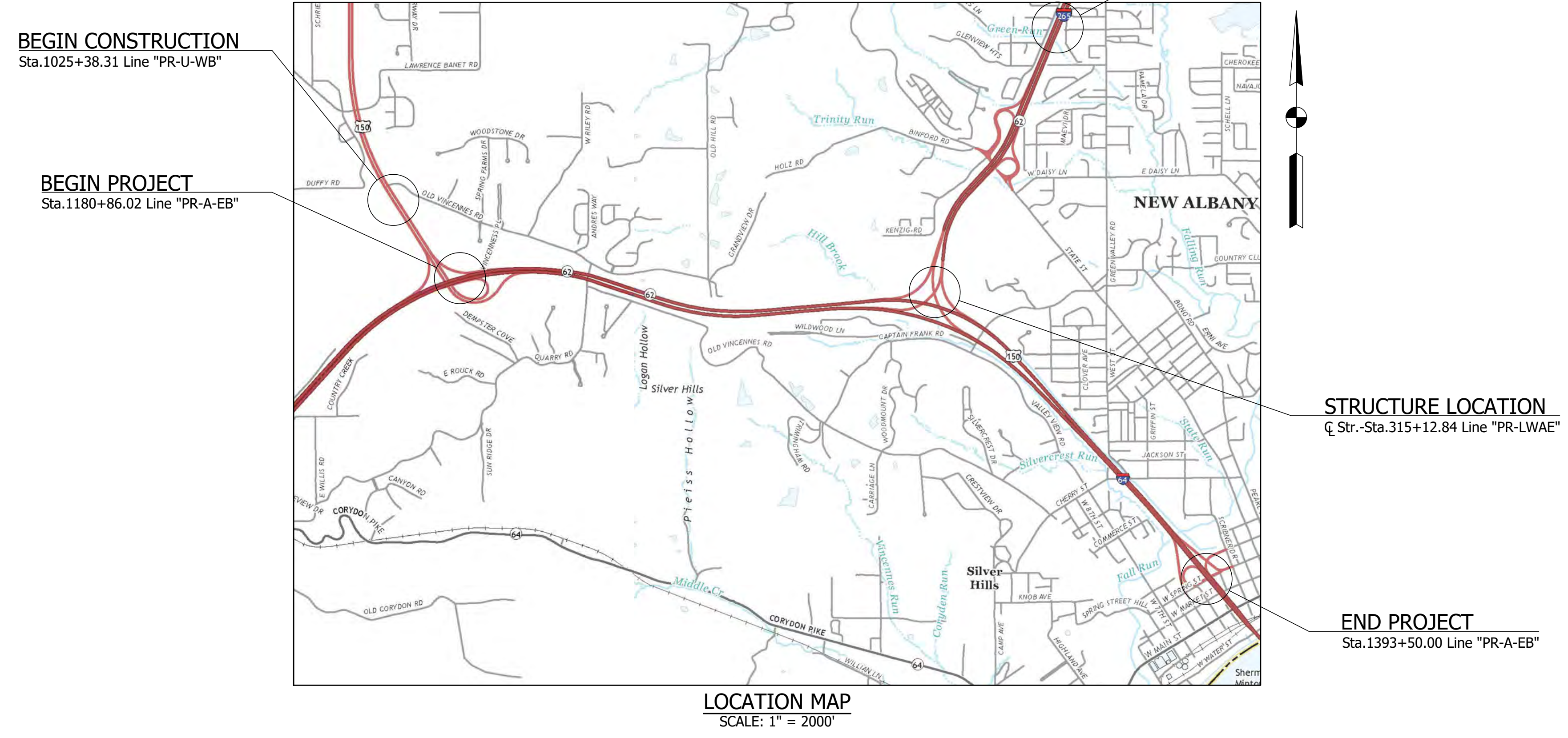

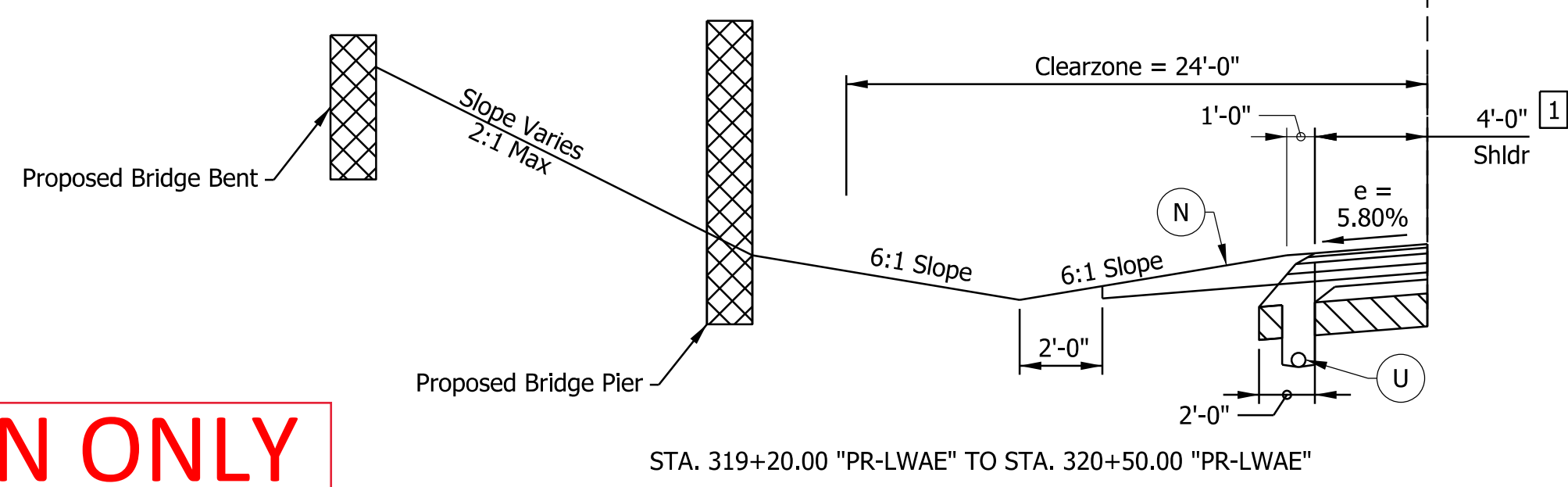
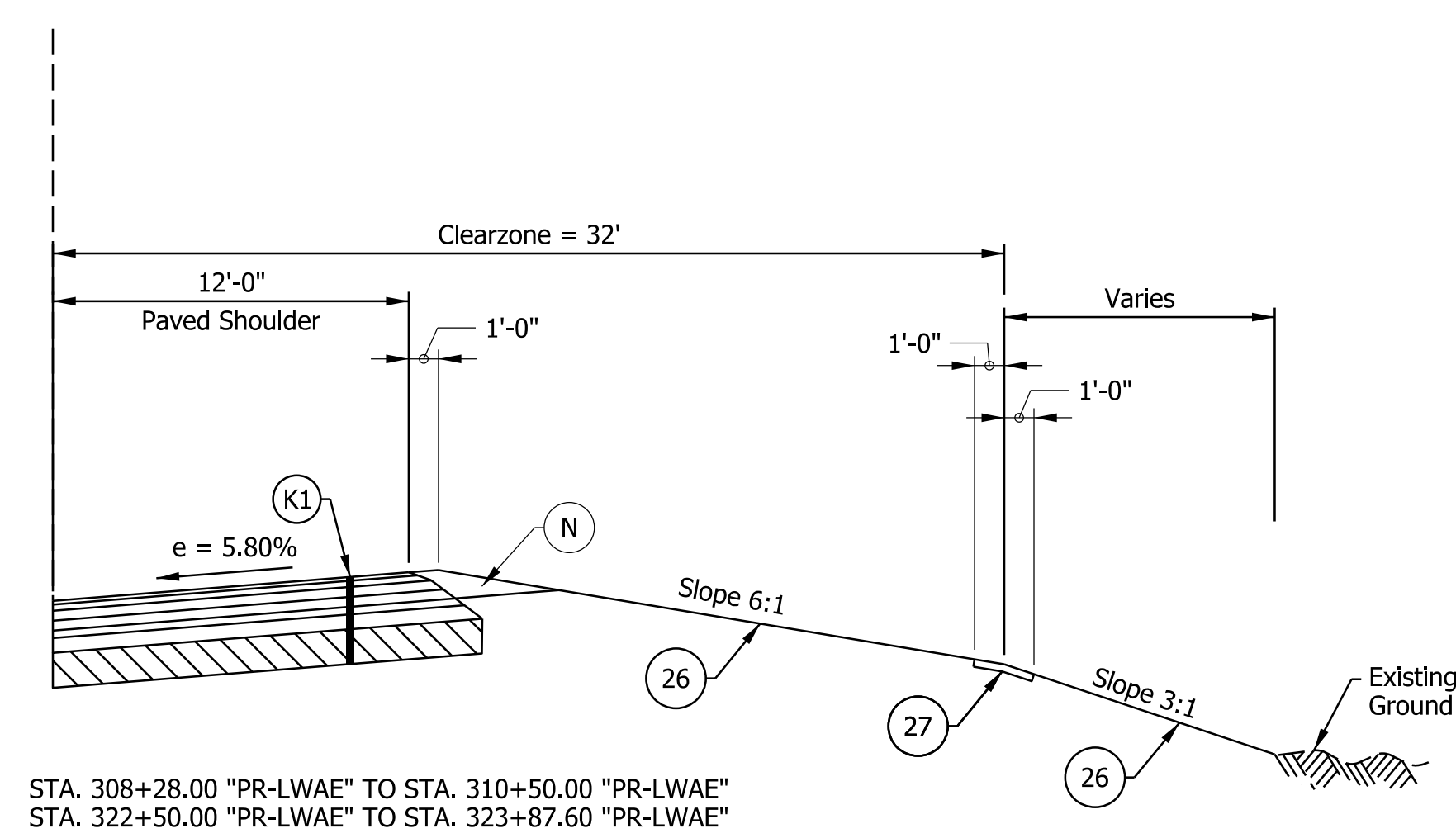
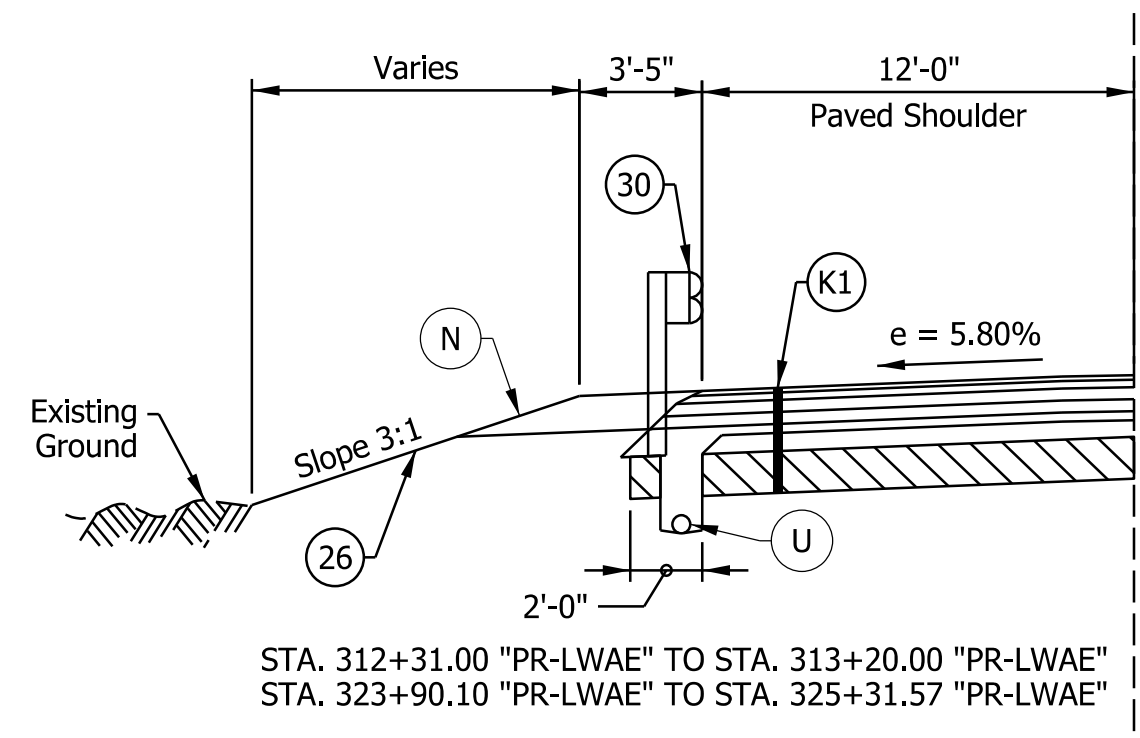
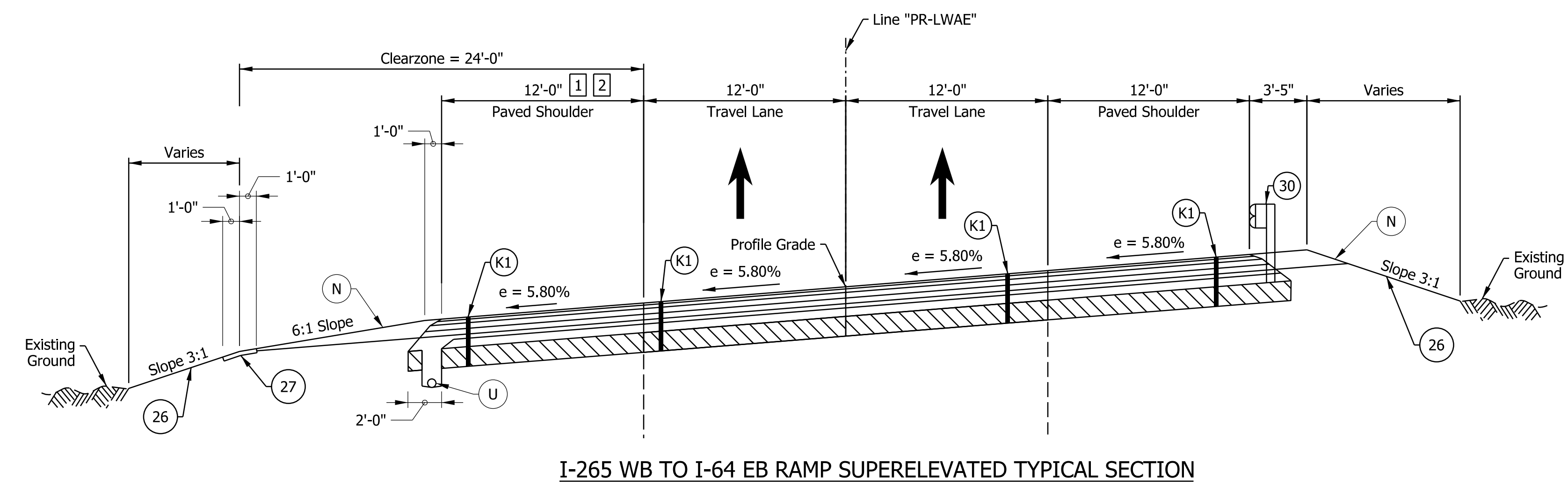
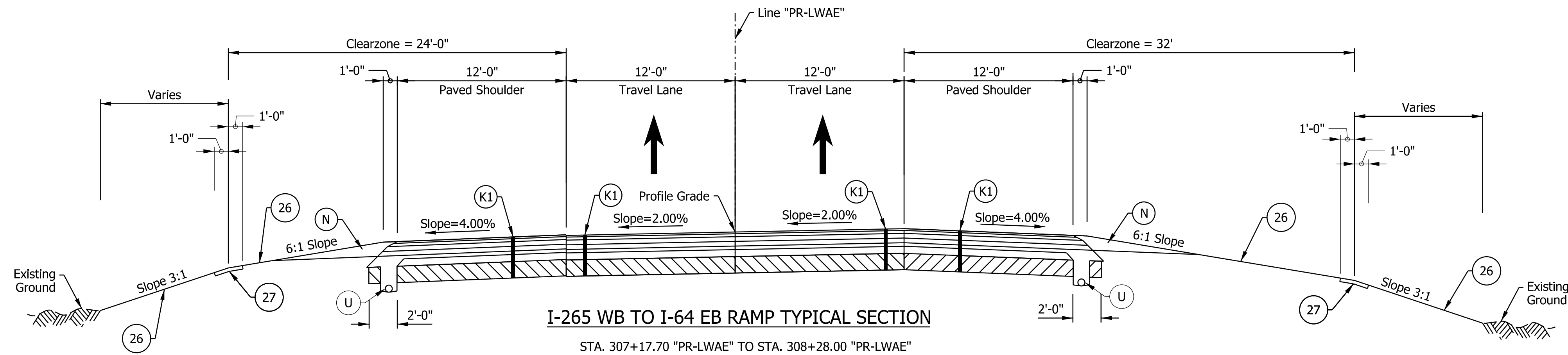

**FOR INFORMATION ONLY**

- Notes:  
 See Sheet LGD-01 for construction legend  
 See Sheet TS-43 for Safety Edge Details
- 1 Paved Shoulder width varies from 12'-0" at 313+00.00 to 12'-4" at 313+15.00  
Paved shoulder width varies from 12'-4" at 316+70.00 to 12'-0" at 316+85.00
  - 2 Paved Shoulder width varies from 12'-0" at Sta. 317+00.00 to 6'-0" at Sta. 319+00.00  
Paved Shoulder width is 6'-0" from Sta. 319+00.00 to 329+86.38

**NOTE TO REVIEWER**  
 Locations and details for underdrain trenches and pipes will be reviewed further for the next submittal.

**NOTE TO REVIEWER**  
 Refer to bridge plans for additional information related to slope paving adjacent to piers/bents

**DRAFT**  
 NOT FOR CONSTRUCTION

RECOMMENDED FOR APPROVAL _____	DESIGN ENGINEER _____	DATE _____
DESIGNED: _____ DFK _____	DRAWN: _____ JKH _____	
CHECKED: _____ ADR _____	CHECKED: _____ ADR _____	

INDIANA  
 DEPARTMENT OF TRANSPORTATION

**I-64 / I-265 INTERCHANGE RAMPS  
 PROPOSED TYPICAL SECTIONS**

HORIZONTAL SCALE	BRIDGE FILE
3/16"=1'-0"	N/A
VERTICAL SCALE	DESIGNATION
N/A	1900162
SURVEY BOOK	SHEETS TS-36
ELECTRONIC	3 of 25
CONTRACT	PROJECT
R-42570	1900162

rsthiegeel  
 12/16/2022; 10:16:36 AM  
 model: TYP-10 [Sheet]  
 file: p:\i-64\I-64\Documents\Indiana\Projects\78704 INDOT-S I-64 ATL 00 CAD-ORD\Sheets\Roadway\1900162\_L\_S\_TYP06.dgn



rstriegel  
 12/15/2022; 7:36:43 PM  
 model: PLN-02 [Sheet]  
 file: p:\i\p\m\hmb\org\PM\Great\_Lakes\Documents\Indianapolis Projects\78704 INDOT-S I-64 ATL 00 CAD-ORD\Sheets\Roadway\1900162\_L\_S\_PLN10.dgn

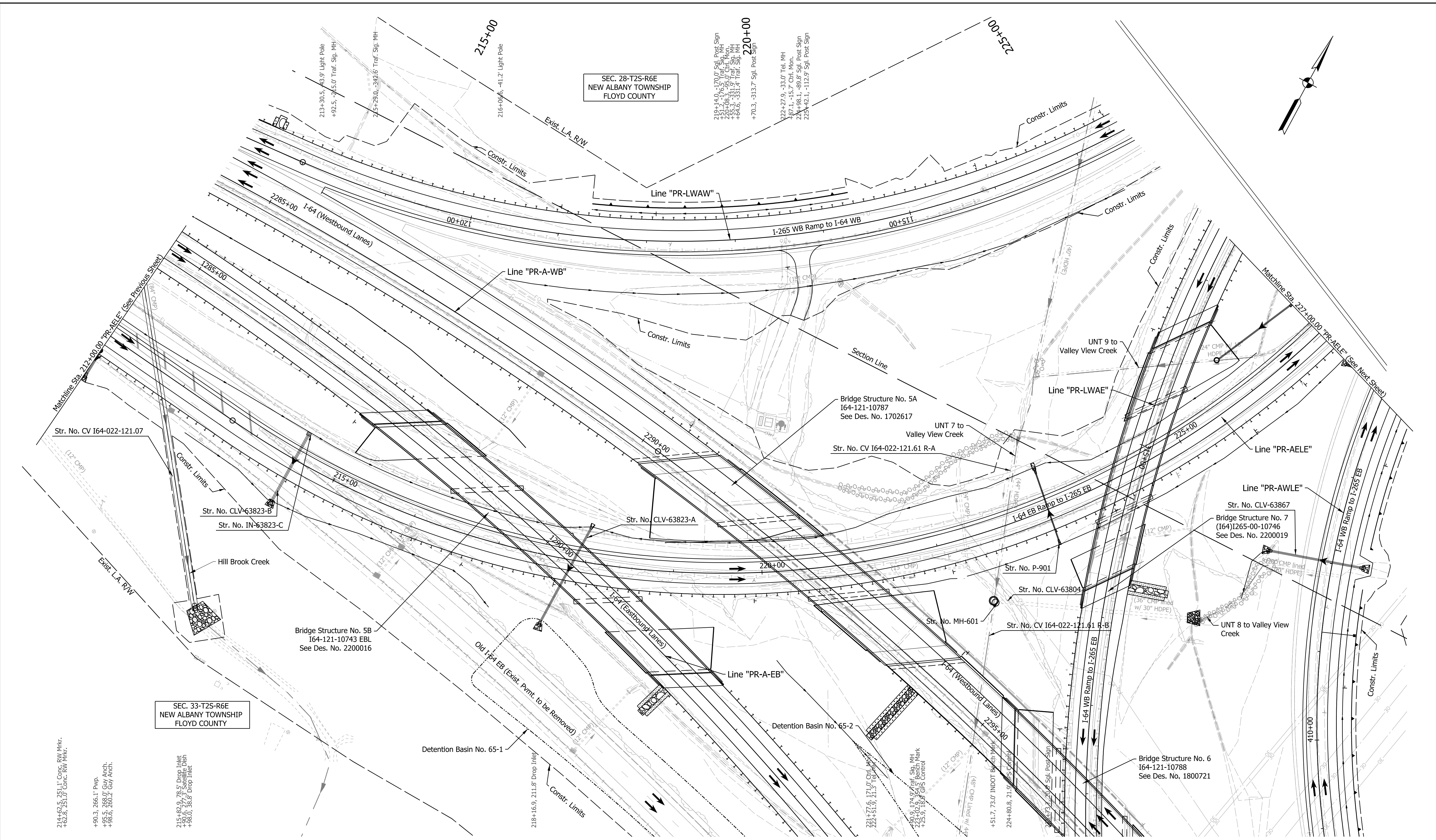

SEC. 28-T25-R6E  
NEW ALBANY TOWNSHIP  
FLOYD COUNTY

SEC. 33-T25-R6E  
NEW ALBANY TOWNSHIP  
FLOYD COUNTY

Note:  
For Geometric information see Geometric Layout Sheets  
GEO-01 to GEO-13.

FOR INFORMATION ONLY

DRAFT

NOT FOR CONSTRUCTION

RECOMMENDED FOR APPROVAL	DESIGN ENGINEER	DATE	
DESIGNED: SGM	DRAWN: RJS		
CHECKED: KRC	CHECKED: KRC		

INDIANA  
DEPARTMENT OF TRANSPORTATION

PLAN SHEET  
LINE "PR-AELE"  
STA. 212+00 TO STA. 227+00

HORIZONTAL SCALE	BRIDGE FILE
1"=50'	N/A
VERTICAL SCALE	DESIGNATION
N/A	1900162
SURVEY BOOK	SHEETS
ELECTRONIC	6 of 25
CONTRACT	PROJECT
R-42570	1900162

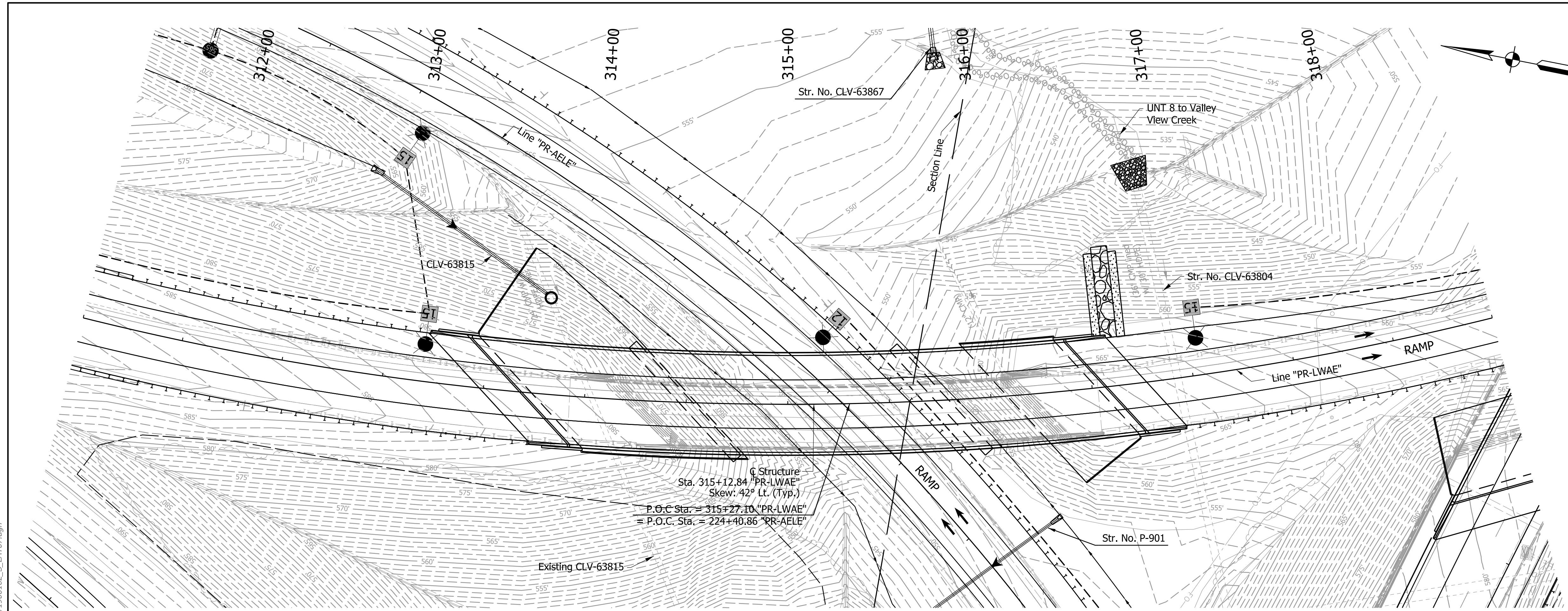

**EXISTING STRUCTURE**  
 Existing structure (I-64)1265-00-05228 B is a Three-span (62'-0", 103'-0" & 31'-0") Continuous Composite Welded Plate Girder Bridge with a 29'-2 3/8" Clear Roadway (To Be Removed)

**EARTHWORK TABULATION**  
 For Earthwork Summary, See Road Plans Des. No. 1900162

**HORIZONTAL CURVE DATA FOR LINE "PR-AELE"**

**CURVE 49**  
 P.I. 224+00.52 "PR-AELE"  
 $\Delta = 93^{\circ}29'31.14"$  LT  
 D = 05°53'40.66"  
 R = 972.00'  
 T = 1033.12'  
 L = 1586.05'  
 E = 446.49'  
 e = 6.00%

**HORIZONTAL CURVE DATA FOR LINE "PR-LWAE"**

**CURVE 59**  
 P.I. 314+65.32 "PR-LWAE"  
 $\Delta = 47^{\circ}54'24.72"$  LT  
 D = 03°59'48.61"  
 R = 1433.53'  
 T = 636.85'  
 L = 1198.62'  
 E = 135.10'  
 e = 5.80%

Sec 28, T-2-S, R-6-E  
 New Albany Township  
 Floyd County

Sec 33, T-2-S, R-6-E  
 New Albany Township  
 Floyd County

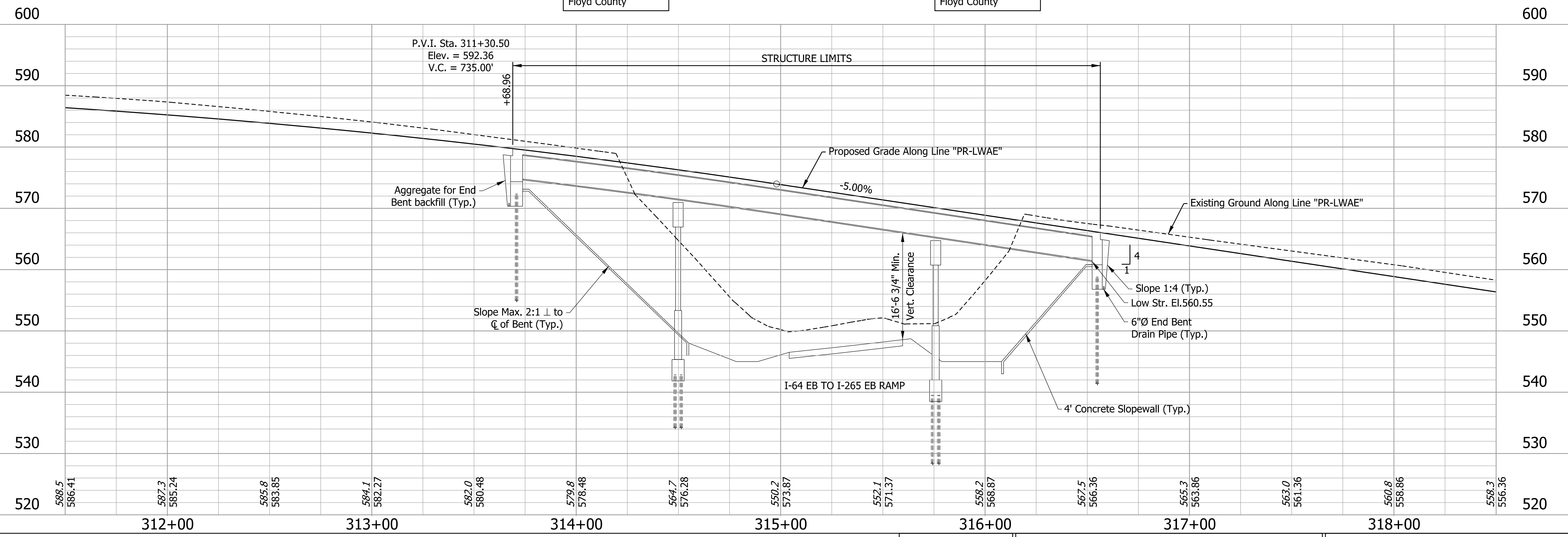

**NOTE:**  
 For Reference Ties and Benchmarks, See Road Plans Des. No. 1900162.  
 For Ditch Grades & Guardrail Limits, See Plan & Profile Sheet of Road Plans, Des. No. 1900162.  
 For existing and proposed utilities, drainage, lighting, signing, and ITS, see Des. No. 1900162.

**CONTINUOUS COMPOSITE CURVED STEEL PLATE GIRDER BRIDGE**  
 3 SPANS: 79'-0", 126'-0" & 79'-0"  
 47'-8" CLEAR ROADWAY SKEW: 42° LT.  
 I-265 WB TO I-64 EB RAMP  
 OVER I-64 EB TO I-265 EB RAMP  
 FLOYD COUNTY

**DRAFT**  
 NOT FOR CONSTRUCTION

RECOMMENDED FOR APPROVAL	DESIGN ENGINEER	DATE
DESIGNED: KB	DRAWN: JP	
CHECKED: TSW	CHECKED: KB	

INDIANA  
 DEPARTMENT OF TRANSPORTATION  
 LAYOUT - LINE "PR-LWAE"

HORIZONTAL SCALE	BRIDGE FILE
1"=30'	(164)1265-00-10746
VERTICAL SCALE	DESIGNATION
1"=10'	2200019
DRAWING NUMBER	SHEETS
S1 of S5	11 of 25
CONTRACT	PROJECT
R-42570	1900162

rstriegel  
 12/5/2022; 1:10:43 PM  
 model: PIN-01 [Sheet]  
 file: p:\p\pin-hmb.org\PMGreat\_Lakes\Documents\Indianapolis Projects\78704 INDOT-S I-64 ATL 00 CAD-ORD\Sheets\Bridge\No. 7 - SB to EB Ramp over EB to NB Ramp\1900162\_S\_LAYOUT.dgn



P.V.I. Sta. 311+30.50 "PR-LWAE"  
1.03%  $\Delta$  -5.00%

STRUCTURE TO BE BUILT ON A 735' V.C. AND -5.00% GRADE

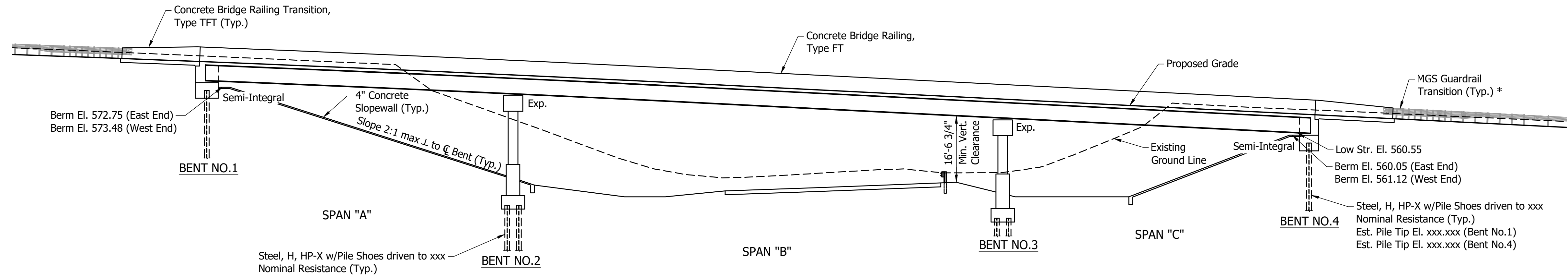

Steel, H, HP-X w/Pile Shoes driven to xxx  
Nominal Resistance (Typ.)  
Est. Pile Tip El. xxx.xxx (Bent No.2)  
Est. Pile Tip El. xxx.xxx (Bent No.3)

**ELEVATION**  
Scale: 1/16" = 1'-0"

**Note to Reviewer:**

- Impact Attenuators are being evaluated for the proposed pier on the inside of the curve of the ramp alignment.
- The Geotechnical Investigation is currently underway. Soil borings, Pile Size and Type will be added at a future submittal.
- Discussions are ongoing regarding the use of squared or skewed RCBA's and Terminal Joint Type based on Optional Bid Pavement Sections. Details will be finalized for the Stage 3 submission.

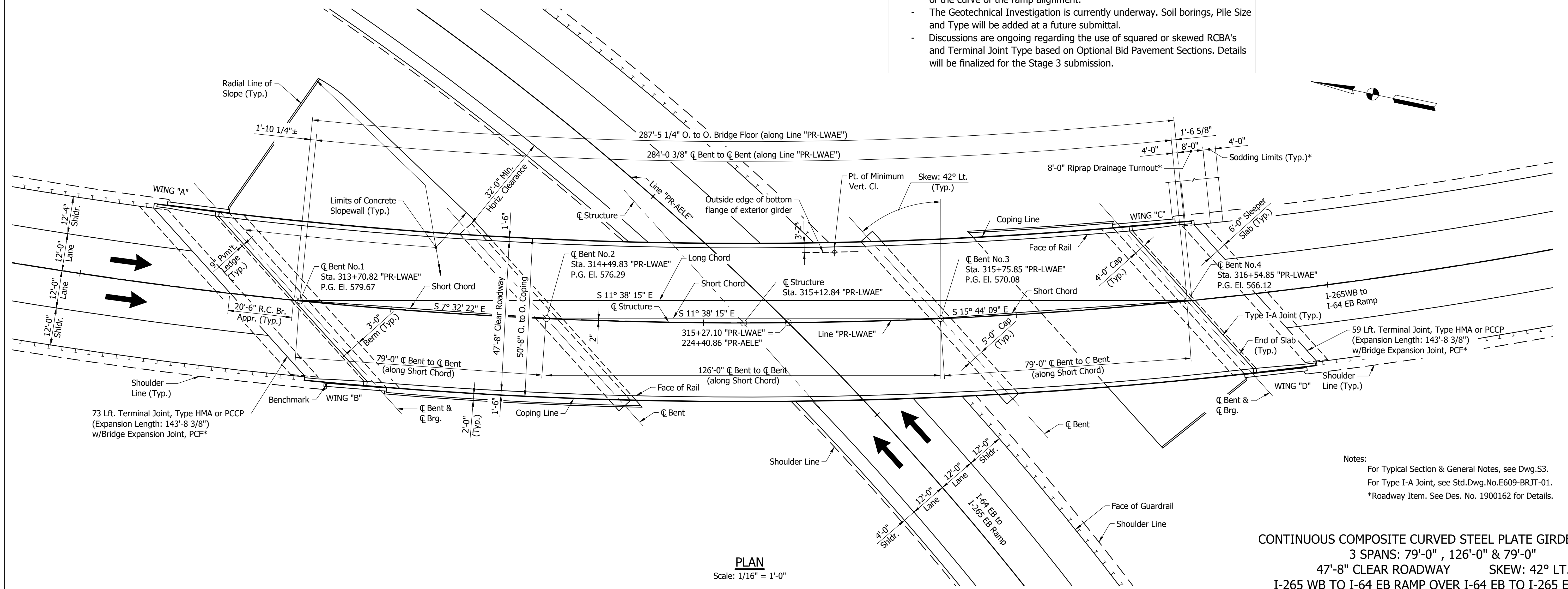
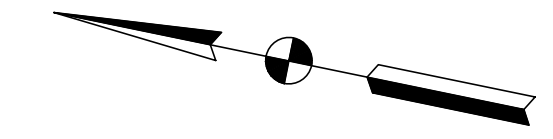

Notes:  
For Typical Section & General Notes, see Dwg.S3.  
For Type I-A Joint, see Std.Dwg.No.E609-BRJT-01.  
\*Roadway Item. See Des. No. 1900162 for Details.

**CONTINUOUS COMPOSITE CURVED STEEL PLATE GIRDER BRIDGE**  
3 SPANS: 79'-0" , 126'-0" & 79'-0"  
47'-8" CLEAR ROADWAY SKEW: 42° LT.  
I-265 WB TO I-64 EB RAMP OVER I-64 EB TO I-265 EB RAMP  
FLOYD COUNTY

**DRAFT**  
NOT FOR CONSTRUCTION

RECOMMENDED FOR APPROVAL	DESIGN ENGINEER	DATE
DESIGNED: KB	DRAWN: JF	
CHECKED: TSW	CHECKED: KB	

INDIANA  
DEPARTMENT OF TRANSPORTATION

**GENERAL PLAN**

HORIZONTAL SCALE	BRIDGE FILE
AS NOTED	(164)1265-00-10746
VERTICAL SCALE	DESIGNATION
AS NOTED	2200019
DRAWING NO.	SHEETS
S2 of S5	12 of 25
CONTRACT	PROJECT
R-42570	1900162

**GENERAL NOTES**

Reinforcing bar covering shall be 2 1/2" in top and 1" minimum in the bottom of the floor slab, 3" in footings except for bottom bars which shall be 4" and 2" in all other parts, unless otherwise noted.

Reinforcing bars in deck, barrier, end bent diaphragms and end bent caps shall be epoxy coated, unless otherwise noted.

All exposed faces of the concrete bridge railings, concrete railing transitions, wings and end bents to be sealed in accordance with Article 702.21 of the Specifications.  
(Estimated Quantity = XXXX Sft.)

**DESIGN DATA**

**LIVE LOAD**

Designed for HL-93 loading, in accordance with the AASHTO LRFD Bridge Design Specifications, Ninth Edition, 2020.

**DEAD LOAD**

Actual weight plus 35 psf (composite) for future wearing surface and 15 psf (non-composite) for permanent metal deck forms.

**FLOOR SLAB**

Designed with 7 1/2" structural depth plus 1/2" sacrificial wearing surface.

**DESIGN STRENGTHS**

To be in accordance with AASHTO LRFD Bridge Design Specifications, Ninth Edition, 2020.

**CONCRETE:**

- Class "A":  $f_c=3,500$  psi
- Class "B":  $f_c=3,000$  psi
- Class "C":  $f_c=4,000$  psi

**REINFORCING BARS:**

- Grade 60:  $F_y=60,000$  psi

**STRUCTURAL STEEL:**

- ASTM A709 Grade 50W:  $F_y=50$  ksi
- ASTM A709 Grade HPS 70W:  $F_y=70$  ksi

**CONSTRUCTION LOADING**

The exterior girders have been checked for strength, deflection, and overturning using the construction loads shown below. Cantilever overhang brackets were assumed for support of the deck overhang past the edge of exterior girder. The finishing machine was assumed to be supported 6 inches outside the vertical coping form. The top overhang brackets were assumed to be located 6 inches past the edge of the vertical coping form. The bottom overhang brackets were assumed to be braced against the intersection of the girder bottom flange and web. The Contractor shall use blocking or other methods to ensure beam rotation does not occur prior to or during concrete placement on exterior girders where diaphragm spacing exceeds 20 ft.

**DECK FALSEWORK LOADS:**

Designed for 15 psf for permanent metal stay-in-place deck forms, removable deck forms, and 2-ft. exterior walkway.

**CONSTRUCTION LIVE LOAD:**

Designed for 20 psf extending 2 ft. past the edge of coping and 75 plf vertical force applied at a distance of 6 inches outside the face of coping over a 30-ft. length of the deck centered with the finishing machine.

**FINISHING-MACHINE LOAD:**

4,500 lbs distributed over 10 ft. along the coping.

**WIND LOAD:**

Designed for 70 mph horizontal wind loading in according with AASHTO LRFD 3.8.1.

**SEISMIC DATA**

AASHTO Guide Design Specifications for LRFD Seismic Bridge Design

Seismic Zone Category X

S1 = X

Site Class X

Fv = X

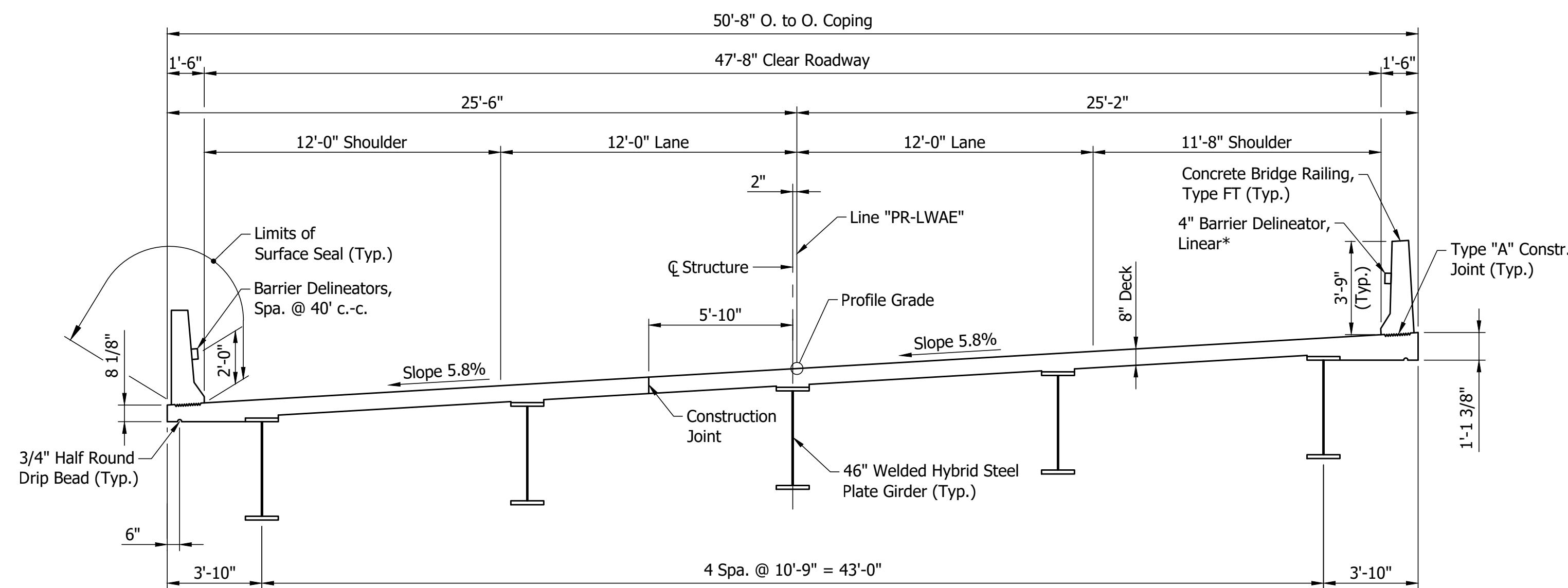

**TYPICAL SECTION**

Scale: 1/4" = 1'-0"

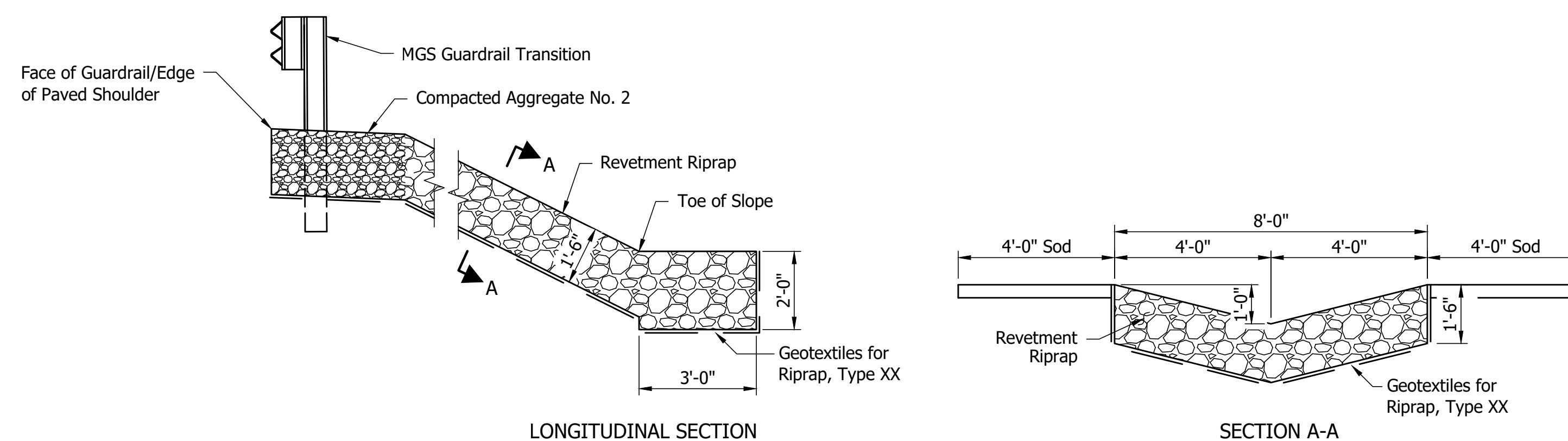

**RIPRAP DRAINAGE TURNOUT DETAIL**

Scale: 3/8" = 1'-0"

**Note to Reviewer:**

- Seismic Data will be provided at a later submittal when the Geotechnical Investigation is available.
- Geotextile Type to be provided when Geotechnical Report is complete
- Surface Seal Quantity to be provided at Stage 3

**Notes:**

For Plan & Elevation, see Dwg.S2.

For Type "A" Construction Joint, see Std.Dwg.No.E702-CJTA-01.

\* See Special Provisions for Linear Barrier Delineator Requirements

**CONTINUOUS COMPOSITE CURVED STEEL PLATE GIRDER BRIDGE**  
 3 SPANS: 79'-0" , 126'-0" & 79'-0"  
 47'-8" CLEAR ROADWAY SKEW: 42° LT.  
 I-265 WB TO I-64 EB RAMP OVER I-64 EB TO I-265 EB RAMP  
 FLOYD COUNTY

<b>DRAFT</b> NOT FOR CONSTRUCTION	RECOMMENDED FOR APPROVAL _____	DESIGN ENGINEER _____ DATE _____	<b>INDIANA DEPARTMENT OF TRANSPORTATION</b>	HORIZONTAL SCALE	BRIDGE FILE
	DESIGNED: KB	DRAWN: JF		AS NOTED	(164)1265-00-10746
	CHECKED: TSW	CHECKED: KB	GENERAL PLAN	VERTICAL SCALE	DESIGNATION
			TYPICAL SECTION	AS NOTED	2200019
			DRAWING NO.	SHEETS	
			S3 of S5	13 of 25	
			CONTRACT	PROJECT	
			R-42570	1900162	

PROJECT	DESIGNATION
1900162	2200017
CONTRACT	BRIDGE FILE
R-42570	164-121-10744

# INDIANA DEPARTMENT OF TRANSPORTATION

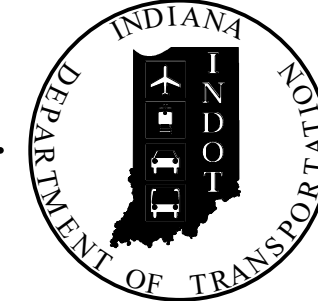

## BRIDGE PLANS

FOR SPANS OVER 20 FEET  
ROUTE: I-64 EB AT: RP 121+96

PROJECT NO. 2200017 P.E.  
1900162 R/W  
2200017 CONST.

Bridge Replacement on I-64 EB over Captain Frank Road  
Located 0.29 Miles East of the Junction with I-265  
Section 33, T-2-S, R-6-E, New Albany Township, Floyd County, Indiana

TRAFFIC DATA	I-64 MAINLINE	I-265 WB TO I-64 EB	CAPTAIN FRANK RD
A.A.D.T. (2019)	66,980 V.P.D.	15,110 V.P.D.	6,860 V.P.D.
A.A.D.T. (2046)	84,980 V.P.D.	18,340 V.P.D.	9,610 V.P.D.
D.H.V (2046)	8,190 V.P.H.	1,900 V.P.H.	1,030 V.P.H.
DIRECTIONAL DISTRIBUTION	68 %	100 %	50 %
TRUCKS	10 % A.A.D.T. 6 % D.H.V.	7 % A.A.D.T. 3 % D.H.V.	1 % A.A.D.T. 0 % D.H.V.

  

DESIGN DATA			
DESIGN SPEED	70 M.P.H.	55 M.P.H.	
PROJECT DESIGN CRITERIA	NEW CONSTRUCTION (FREEWAY)	4R (FREEWAY)	NO IMPROVEMENT
FUNCTIONAL CLASSIFICATION	PRINCIPAL ARTERIAL	RAMP	
RURAL/URBAN	URBAN	URBAN	
TERRAIN	ROLLING	ROLLING	
ACCESS CONTROL	FULL	FULL	

DESIGNATION	PROJECT DESCRIPTION	
ROAD		
1900162	I-64 ATL	LEAD DES.
1900366	US 150 and Old Vincennes Road (East)	
2100019	I-64 Lighting US 150 to I-64 / I-265	
BRIDGE		
1800706	Bridge Painting on US 150 EB over I-64, Str.No. 150-22-04983 AEBL	STR. 1
1800405	Bridge Painting on US 150 EB over I-64, Str.No. 150-22-04983 AWBL	STR. 2
1700207	Bridge Replacement on I-64 EB over Quarry Road, Str.No. 164-120-10786	STR. 3
2200015	Bridge Replacement on I-64 WB over Quarry Road, Str.No. 164-120-10742	STR. 4
1702617	Bridge Replacement on I-64 WB over I-64 EB to I-265 EB Ramp, Str.No. 164-121-10787	STR. 5A
2200016	New Bridge on I-64 EB over I-64 EB Ramp to I-265 EB, Str.No.164-121-10743 EBL	STR. 5B
1800721	Bridge Replacement on I-64 WB over I-265 WB Ramp to I-64 EB, Str.No.164-121-10788	STR. 6
2200019	Bridge Replacement on I-265 WB to I-64 EB Ramp over I-265 EB Ramp, Str.No.(164)I265-00-10746	STR. 7
2200017	Bridge Replacement on I-64 EB over Captain Frank Road, Str.No.164-121-10744	STR. 8
2200018	Superstructure Replacement on I-64 WB over Captain Frank Road, Str. No. 164-121-04986 DWBL	STR. 9
1702614	Bridge Deck Overlay on I-64 over Cherry Street, Str.No. 164-122-04988 D	STR. 10
2000326 / 2000323	Bridge Deck Replacement & Widening on I-265 EB & Ramp Over State Street, Str.No. 1265-00-05513 JCEB & DRCB	STR. 11
2000324	Bridge Deck Overlay on I-265 WB Over State Street, Str.No. 1265-00-05513 DWBL	STR. 12
1700206	Bridge Deck Replacement I-64 EB over SR 62/ SR 64	STR. 13
1700205	Bridge Deck Replacement on I-64 WB over SR 62/ SR 64	STR. 14
2000144	Bridge Deck Overlay on I-64 EB over Yenowine Lane	STR. 15
2000145	Bridge Deck Overlay on I-64 WB over Yenowine Lane	STR. 16
2002072	US 150 EB over Little Indian Creek, Str.No.150-22-05230 CEB	STR. 18
2002073	US 150 WB over Little Indian Creek, Str.No.150-22-05230 CWB	STR. 19
2200719	I-64 EB & WB over SR 62 / Spring Street, Str.No.164-123-04689 C	STR. 20
2200718	I-64 WB Off-Ramp to Spring Street over I-64 WB On-Ramp from Spring Street, Str.No.164-123-04688 D	STR. 21
DRAINAGE		
TBD	US 150 Twin Arch Pipe Liner	STR. 17
TBD	Valley View Creek (6 Small Structures and 7 Small Pipe Replacements)	
TBD	Valley View Creek CMP Liner	
TBD	UNT to Little Indian Creek CMP Liner	
TBD	Hill Brook CMP Liner	
TBD	Small Pipes CMP Liners (2)	

BEGIN CONSTRUCTION  
Sta.1025+38.31 Line "PR-U-WB"

BEGIN PROJECT  
Sta.1180+86.02 Line "PR-A-EB"

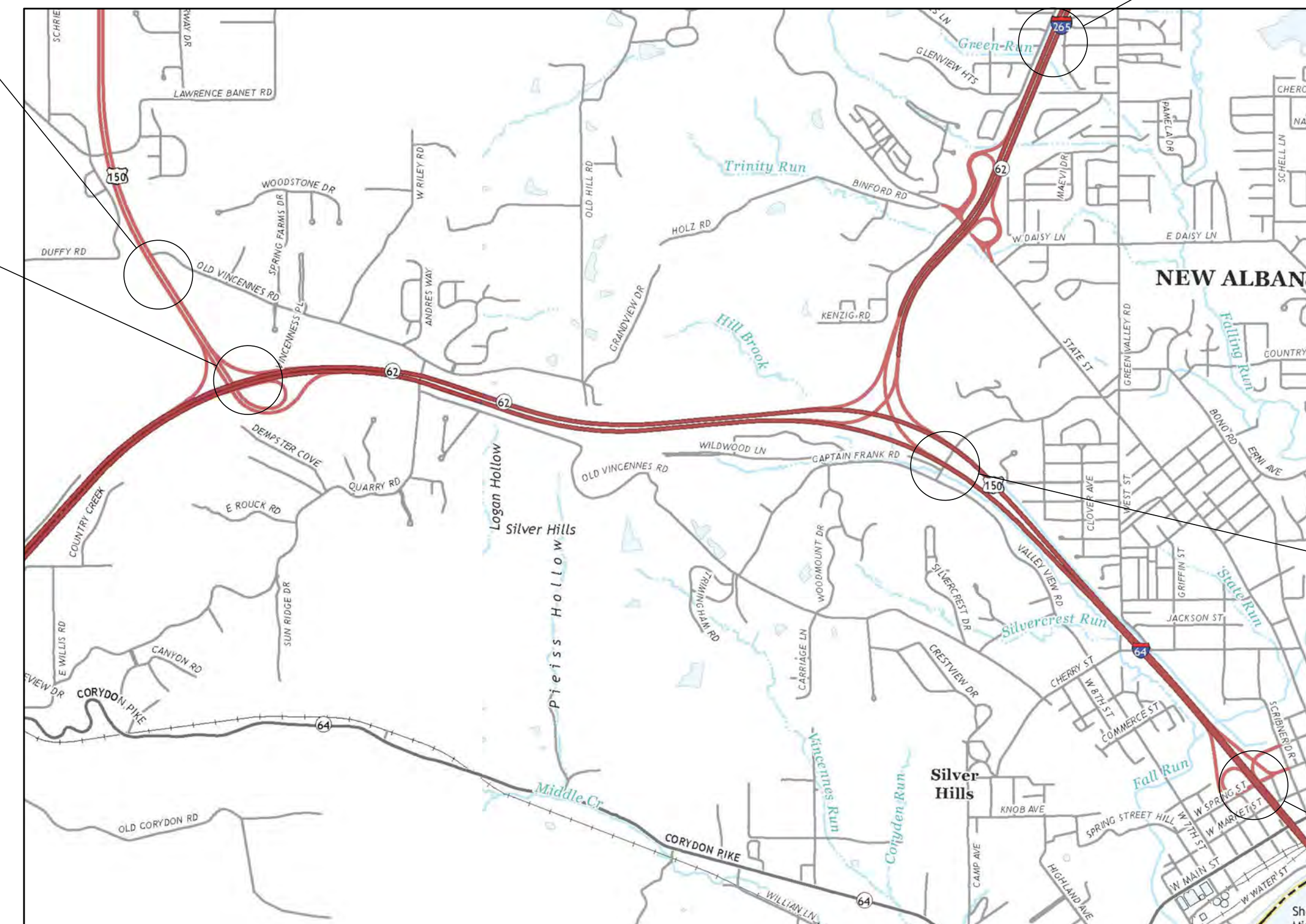

END CONSTRUCTION  
Sta.2077+97.42 Line "PR-L-EB"

STRUCTURE LOCATION  
Ç Str.-Sta.1307+22.85 Line "PR-A-EB"

END PROJECT  
Sta.1393+50.00 Line "PR-A-EB"

LOCATION MAP  
SCALE: 1" = 2000'

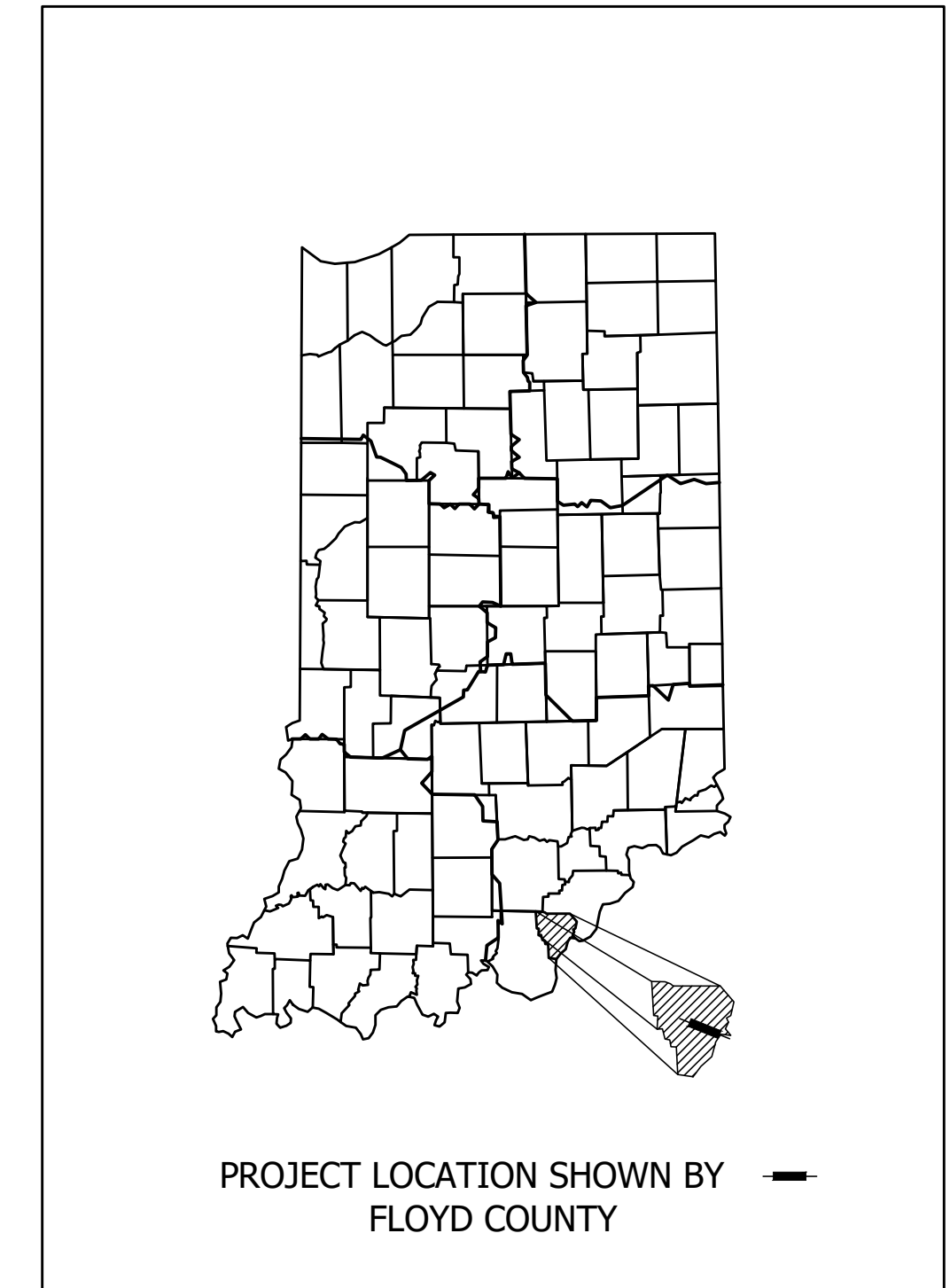

LATITUDE: 38°17'58.31" N LONGITUDE: 85°50'49.25" W

BRIDGE LENGTH: 0.014 MI.  
ROADWAY LENGTH: \* MI.  
TOTAL LENGTH: \* MI.  
MAX. GRADE: 4.50 %  
\* SEE DES. NO. 1900162

HUC 12: 051401010904  
HUC 14: 05140101150020

Note to Reviewer:  
The list of Kinned Projects is tentative and subject to change at INDOT Seymour District's direction. This list represents the current understanding of the Contract Package

### STAGE 2 PLANS

PLANS PREPARED BY:

8320 CRAIG STREET | INDIANAPOLIS, IN 46250  
317.849.5832 | F: 317.841.4280 | WWW.B-L-N.COM

**DRAFT**  
NOT FOR CONSTRUCTION

PLANS PREPARED BY: BEAM, LONGEST & NEFF, LLC (317)849-5832 PHONE NUMBER  
CERTIFIED BY: \_\_\_\_\_ DATE  
APPROVED FOR LETTING: \_\_\_\_\_ DATE  
INDIANA DEPARTMENT OF TRANSPORTATION

BRIDGE FILE	
164-121-10744	
DESIGNATION	
2200017	
DRAWING NO.	SHEETS
1	of 26
CONTRACT	PROJECT
R-42570	1900162

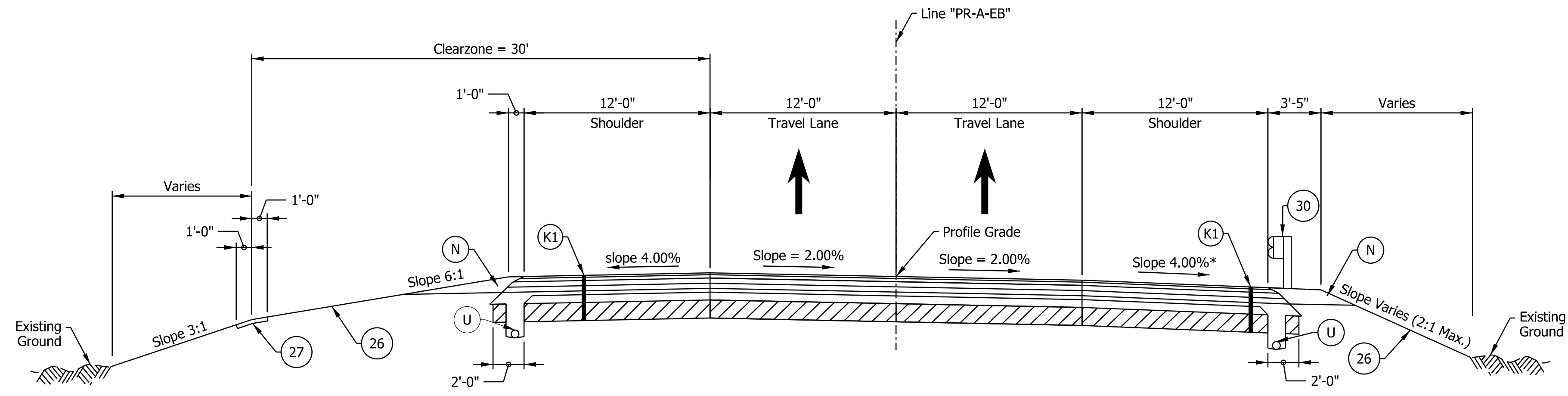

**I-64 EB TYPICAL SECTION**  
 STA. 1299+86.00 "PR-A-EB" TO STA. 1301+63.65 "PR-A-EB"

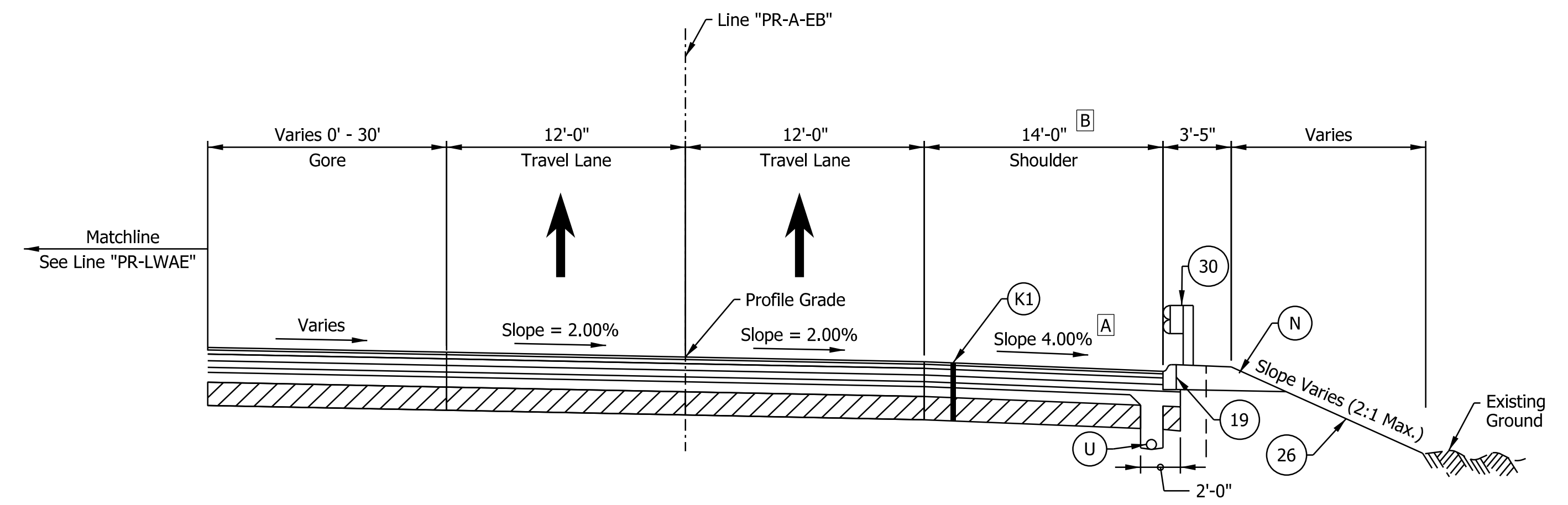

**I-64 EB TYPICAL SECTION**  
 STA. 1301+63.65 "PR-A-EB" TO STA. 1306+50.00 "PR-A-EB"

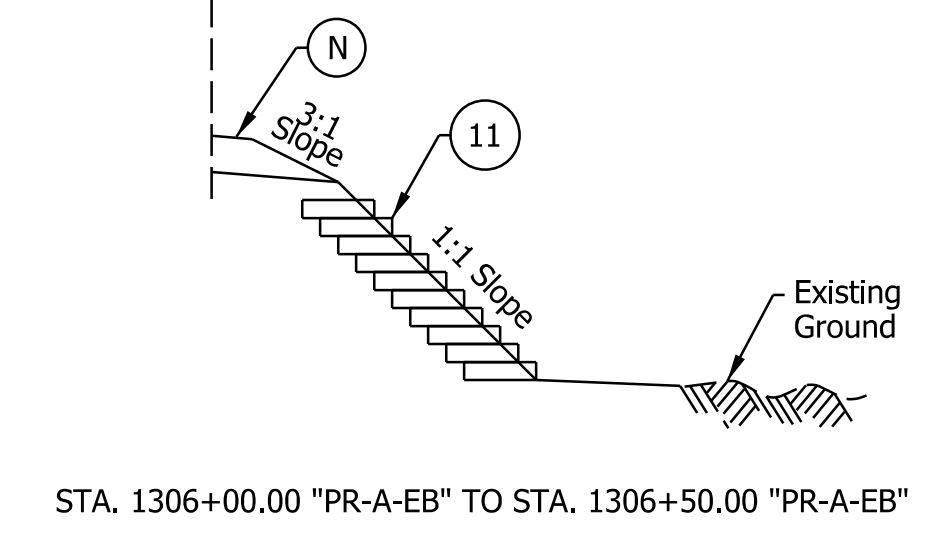

STA. 1306+00.00 "PR-A-EB" TO STA. 1306+50.00 "PR-A-EB"

- Notes:
- See Sheet LGD-01 for construction legend
  - See Sheet TS-43 for Safety Edge Details
  - See Sheet DET-03 for Reinforced Side Slope details.
  - \* Max rollover between shoulder and travel lane not to exceed 8%.
  - A** Shoulder slope to rotate to match adjacent lanes across the bridge over Captain Frank Road
  - B** Left shoulder width increased to 12'-4" approaching and exiting the bridge over Captain Frank Road  
 Right shoulder width reduced to 13'-8" across the bridge over Captain Frank Road

arcsenmeyer 12/11/2022 10:42:47 AM  
 model: TYP-05 [Sheet]  
 file: p:\i\p\in\hmb.org\PM\Great\_Lakes\Documents\Indianapolis Projects\78704 INDOT-S I-64 ATL\00 CAD-ORD\Sheets\Roadway\1900162\_L\_S\_TYP02.dgn

**NOTE TO REVIEWER**  
 2-foot lane extensions at the shoulders will be reviewed and implemented where applicable in a future submittal.

FOR INFORMATION ONLY

DRAFT

NOT FOR CONSTRUCTION

RECOMMENDED FOR APPROVAL _____	DESIGN ENGINEER _____ DATE _____
DESIGNED: _____ SGM _____	DRAWN: _____ CGR _____
CHECKED: _____ ADR _____	CHECKED: _____ ADR _____

INDIANA  
 DEPARTMENT OF TRANSPORTATION

I-64 EASTBOUND MAINLINE  
 PROPOSED TYPICAL SECTIONS

HORIZONTAL SCALE 3/16"=1'-0"	BRIDGE FILE N/A
VERTICAL SCALE N/A	DESIGNATION 1900162
SURVEY BOOK ELECTRONIC	SHEETS 3 of 26
CONTRACT R-42570	PROJECT 1900162

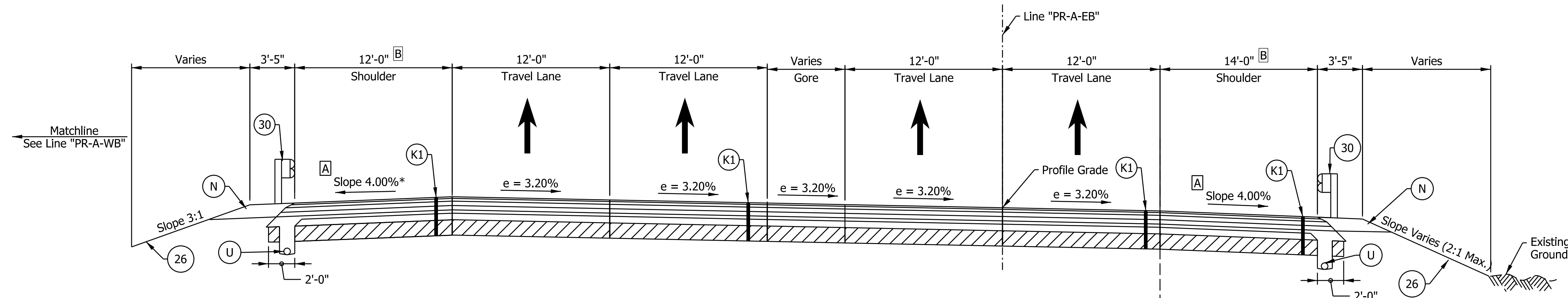

**I-64 EB SUPERELEVATED TYPICAL SECTION**  
 STA. 1306+50.00 "PR-A-EB" TO STA. 1316+65.36 "PR-A-EB"  
 Bridge Paving Exception from Sta. 1306+63.50 to 1307+82.00

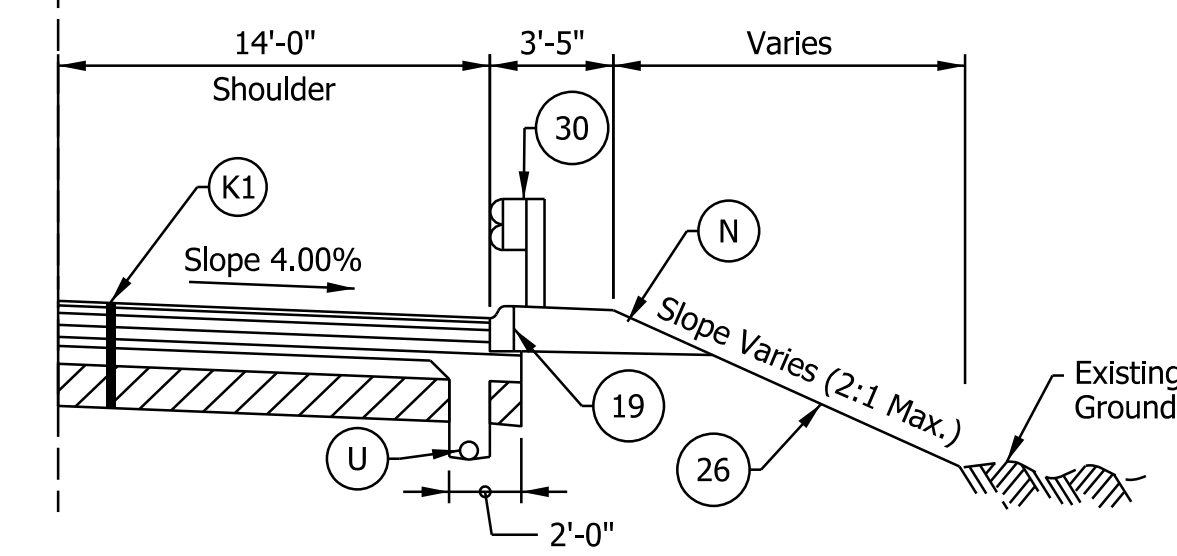

STA. 1307+92.00 "PR-A-EB" TO STA. 1316+60.00 "PR-A-EB"

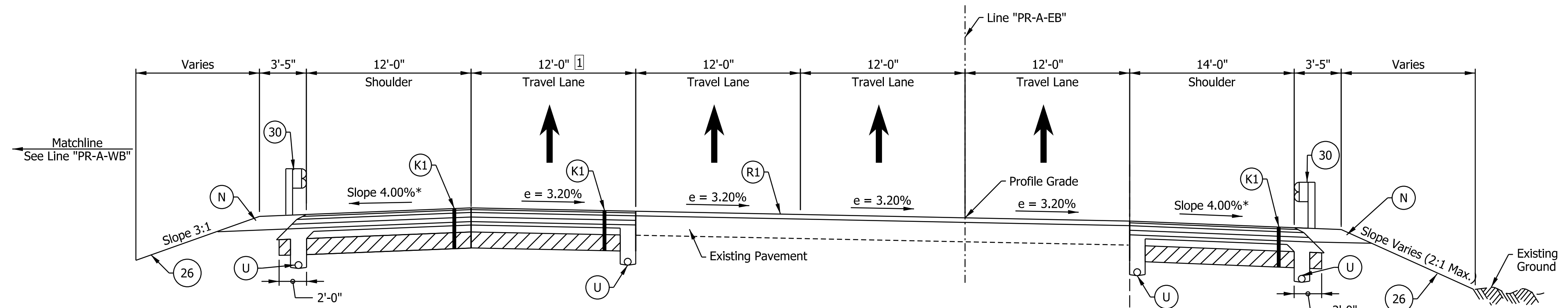

**I-64 EB SUPERELEVATED TYPICAL SECTION**  
 STA. 1316+65.36 "PR-A-EB" TO STA. 1328+04.00 "PR-A-EB"

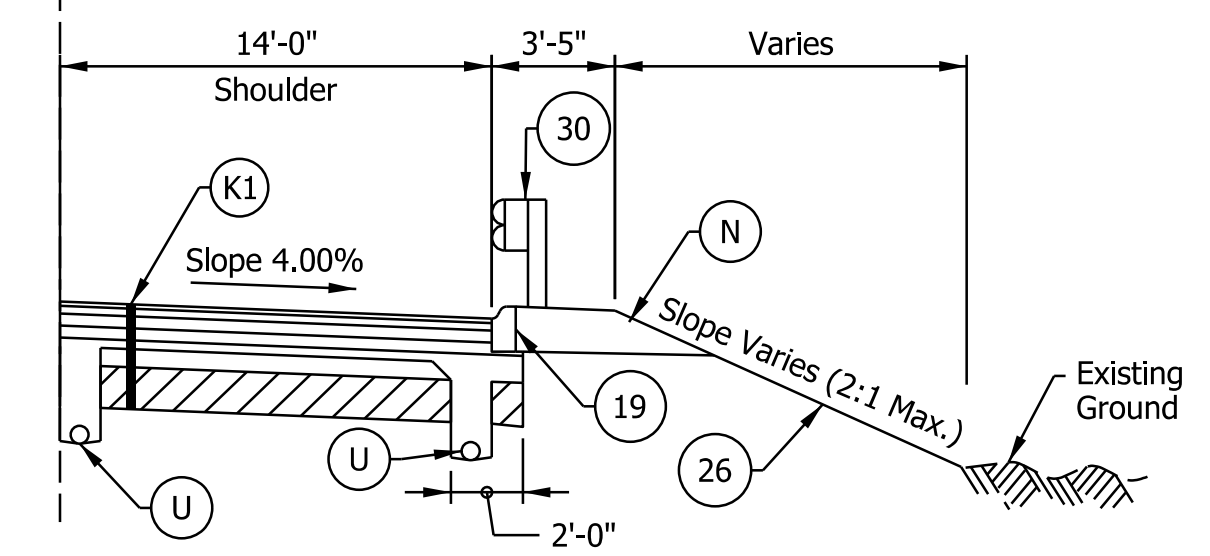

STA. 1316+60.00 "PR-A-EB" TO STA. 1317+50.00 "PR-A-EB"

- Notes:
- See Sheet LGD-01 for construction legend
  - See Sheet TS-43 for Safety Edge Details
  - \* Max rollover between shoulder and travel lane not to exceed 8%.
  - 1 Lane width varies from 12'-0" at Sta. 1324+58.76 to 0'-0" Sta. 1333+98.76
  - A Shoulder slope to rotate to match adjacent lanes across the bridge over Captain Frank Road
  - B Left shoulder width increased to 12'-4" approaching and exiting the bridge over Captain Frank Road  
Right shoulder width reduced to 13'-8" across the bridge over Captain Frank Road

**NOTE TO REVIEWER**  
 2-foot lane extensions at the shoulders will be reviewed and implemented where applicable in a future submittal.

**FOR INFORMATION ONLY**

**DRAFT**  
 NOT FOR CONSTRUCTION

RECOMMENDED FOR APPROVAL _____	DESIGN ENGINEER _____	DATE _____
DESIGNED: _____ SGM _____	DRAWN: _____ CGR _____	
CHECKED: _____ ADR _____	CHECKED: _____ ADR _____	

INDIANA  
 DEPARTMENT OF TRANSPORTATION

**I-64 EASTBOUND MAINLINE  
 PROPOSED TYPICAL SECTIONS**

HORIZONTAL SCALE	BRIDGE FILE
3/16"=1'-0"	N/A
VERTICAL SCALE	DESIGNATION
N/A	1900162
SURVEY BOOK	SHEETS TS-06
ELECTRONIC	4 of 26
CONTRACT	PROJECT
R-42570	1900162

arcosmeyer 12/11/2022 10:42:48 AM  
 model: TYP-06 [Sheet]  
 file: p:\i-64\in\hmb.org\PMGreat\_Lakes\Documents\Indianapolis\Projects\78704 INDOT-S I-64 ATL 00 CAD-ORD\Sheets\Roadway\1900162\_S\_TYP02.dgn

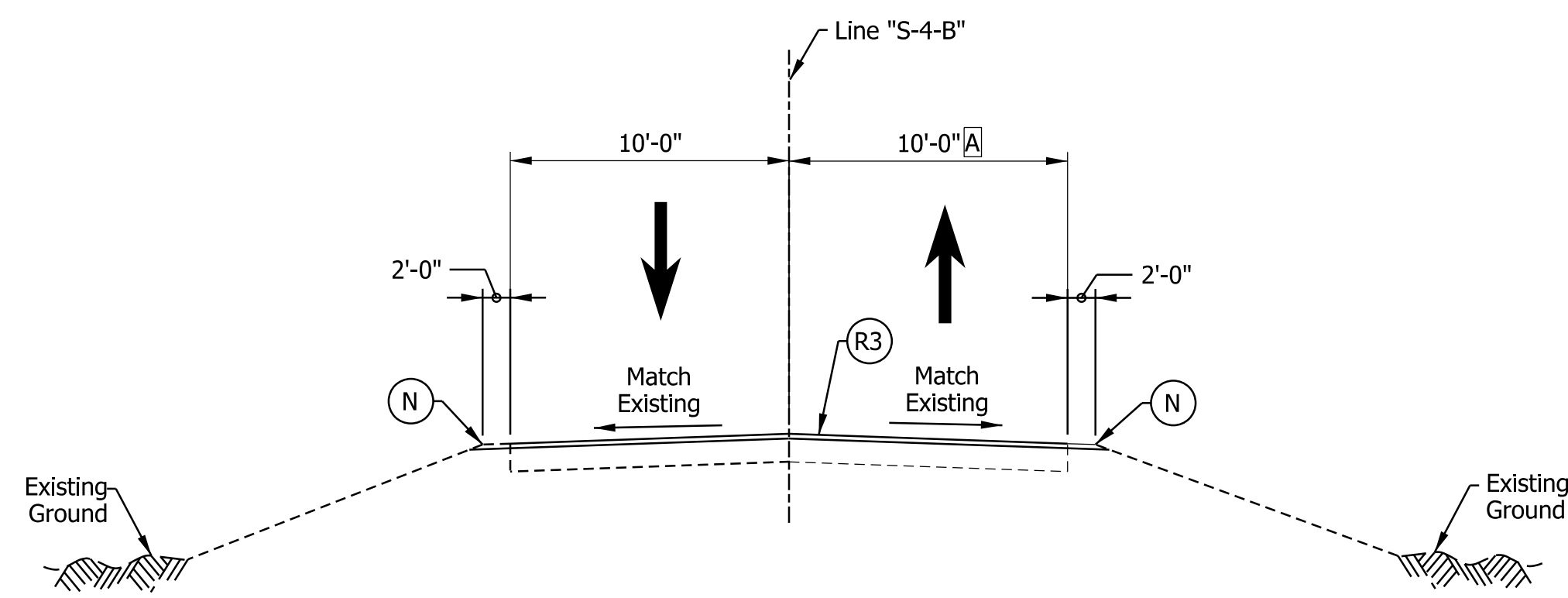

**Captain Frank Road Typical Section**  
 STA. 48+50.00 "S-4-B" TO STA. 54+00.00 "S-4-B"

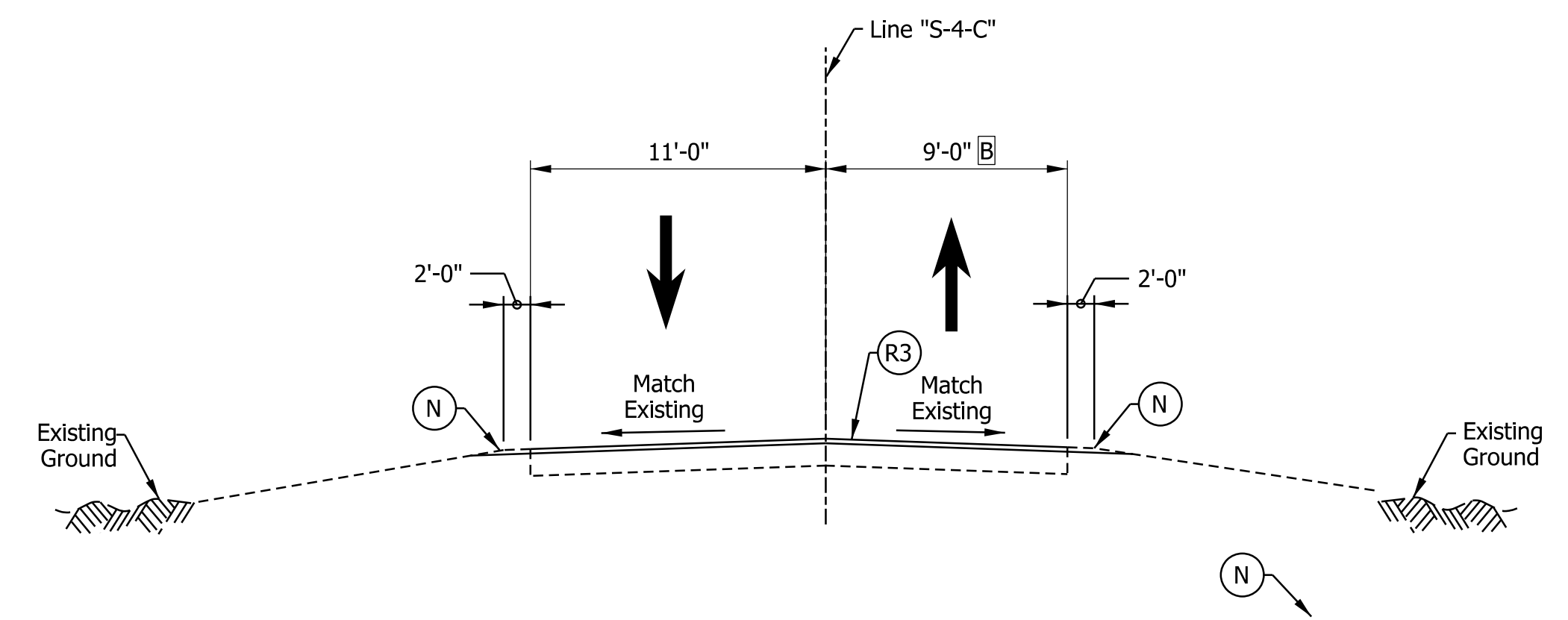

**Quarry Road Typical Section**  
 STA. 47+31.00 "S-4-C" TO STA. 51+70.00 "S-4-C"

**Notes:**

See Sheet LGD-01 for construction legend  
 See Sheet TS-43 for Safety Edge Details

- Ⓐ Northbound Travel Lane is 10'-0" from Sta. 48+50 "S-4-B" to Sta. 52+50 "S-4-B"  
 Northbound Travel Lane Varies from 10'-0" to 11'-6" from Sta. 52+50 "S-4-B" to Sta. 54+00 "S-4-B"
- Ⓑ Northbound Travel Lane Varies from 9'-0" to 14'-6" from Sta. 51+25 "S-4-C" to Sta. 51+70 "S-4-C"

**FOR INFORMATION ONLY**

**DRAFT**  
 NOT FOR CONSTRUCTION

RECOMMENDED FOR APPROVAL _____	DESIGN ENGINEER _____	DATE _____
DESIGNED: _____ JKH _____	DRAWN: _____ JKH _____	
CHECKED: _____ ADR _____	CHECKED: _____ ADR _____	

**INDIANA**  
**DEPARTMENT OF TRANSPORTATION**

**QUARRY ROAD / CAPTAIN FRANK ROAD**  
**PROPOSED TYPICAL SECTIONS**

HORIZONTAL SCALE	BRIDGE FILE
3/16"=1'-0"	N/A
VERTICAL SCALE	DESIGNATION
N/A	1900162
SURVEY BOOK	SHEETS
ELECTRONIC	5 of 26
CONTRACT	PROJECT
R-42570	1900162

rstriegel 12/1/2022 10:44:14 AM  
 model: TYP-01 [Sheet]  
 file: p:\i\p\in\hmb\org\PIGreat\_Lakes\Documents\Indianapolis Projects\78704 INDOT-S I-64 ATL\00 CAD-ORD\Sheets\Roadway\1900162\_S\_TYP06.dgn

12/11/2022; 12:19:51 PM  
 model: PLN-09 [Sheet]  
 file: p:\i\p\m\h\m\m\org\PM\Great\_Lakes\Documents\Indianapolis Projects\78704 INDOT-S I-64 ATL 00 CAD-ORD\Sheets\Roadway\1900162\_S\_PLN01.dgn

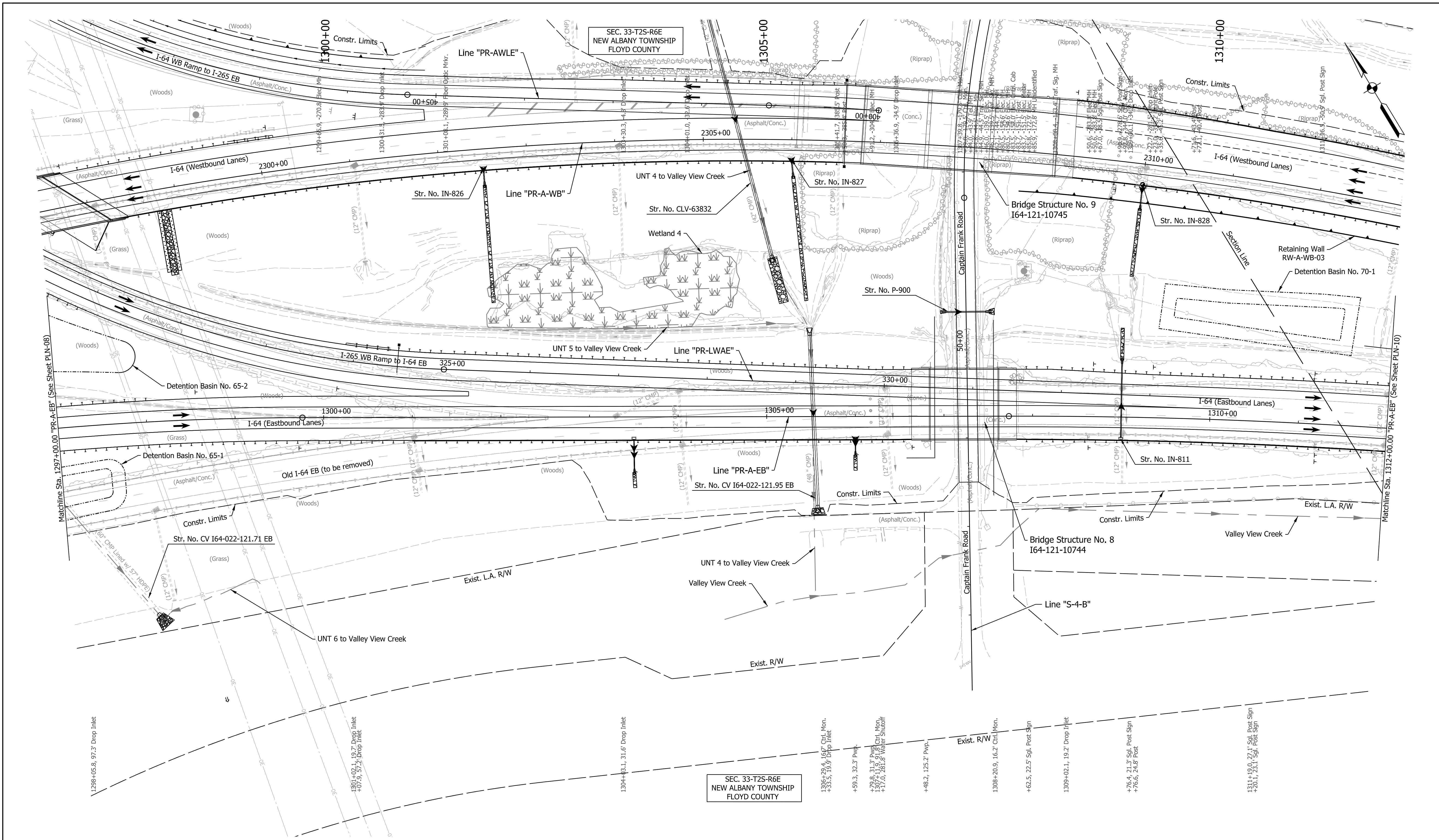

Note:  
 For Geometric information see Geometric Layout Sheets  
 GEO-01 to GEO-13.

FOR INFORMATION ONLY

DRAFT

NOT FOR CONSTRUCTION

RECOMMENDED FOR APPROVAL	DESIGN ENGINEER	DATE
DESIGNED: SGM	DRAWN: RJS	
CHECKED: KRC	CHECKED: KRC	

INDIANA  
 DEPARTMENT OF TRANSPORTATION  
  
 PLAN SHEET  
 LINE "PR-A-EB"  
 STA. 1297+00 TO STA. 1312+00

HORIZONTAL SCALE	BRIDGE FILE	
1"=50'	N/A	
VERTICAL SCALE	DESIGNATION	
N/A	1900162	
SURVEY BOOK	SHEETS	PLN-09
ELECTRONIC	6	of 26
CONTRACT	PROJECT	
R-42570	1900162	









**GENERAL NOTES**

Reinforcing bar covering shall be 2 1/2" in top and 1" minimum in the bottom of the floor slab, 3" in footings except for bottom bars which shall be 4" and 2" in all other parts, unless otherwise noted.

Reinforcing bars in deck, barrier, end bent diaphragms and end bent caps shall be epoxy coated, unless otherwise noted.

The concrete bridge railings, concrete railing transitions and all exposed surfaces of wings and end bents to be sealed in accordance with Article 702.21 of the Specifications.  
(Estimated Quantity = XXXX Sft.)

**DESIGN DATA**

**LIVE LOAD**

Designed for HL-93 loading, in accordance with the AASHTO LRFD Bridge Design Specifications, Ninth Edition, 2020.

**DEAD LOAD**

Actual weight plus 35 psf (composite) for future wearing surface and 15 psf (non-composite) for permanent metal deck forms.

**FLOOR SLAB**

Designed with 7 1/2" structural depth plus 1/2" sacrificial wearing surface.

**DESIGN STRENGTHS**

To be in accordance with AASHTO LRFD Bridge Design Specifications, Ninth Edition, 2020.

**PRESTRESSED CONCRETE, NORMAL WEIGHT:**

$f_c=8,000$  psi @ 28 days  
Initial  $f_c=6,000$  psi @ Release of Strands

**PRESTRESSING STRANDS:**

0.6"  $\varnothing$  7 Wire LoLax Strands ( $A_s=0.217$  in<sup>2</sup>)  
Min. Tensile Strength=270,000 psi  
Initial Pull=43,940 lbs. per strand

**CONCRETE:**

Class "A":  $f_c=3,500$  psi  
Class "C":  $f_c=4,000$  psi

**REINFORCING BARS:**

Grade 60:  $F_y=60,000$  psi

**SEISMIC DATA**

AASHTO Guide Design Specifications for LRFD Seismic Bridge Design

Seismic Zone X

S1 = X.XX

Site Class X

Fv = X.XX

**CONSTRUCTION LOADING**

The exterior beams have been checked for strength, deflection, and overturning using the construction loads shown below. Cantilever overhang brackets were assumed for support of the deck overhang past the edge of exterior beam. The finishing machine was assumed to be supported 6 inches outside the vertical coping form. The top overhang brackets were assumed to be located 6 inches past the edge of the vertical coping form. The bottom overhang brackets were assumed to be braced against the intersection of the beam bottom flange and web. The Contractor shall use blocking or other methods to ensure beam rotation does not occur prior to or during concrete placement on exterior beams where diaphragm spacing exceeds 20 ft.

**DECK FALSEWORK LOADS:**

Designed for 15 psf for permanent metal stay-in-place deck forms, removable deck forms, and 2-ft. exterior walkway.

**CONSTRUCTION LIVE LOAD:**

Designed for 20 psf extending 2 ft. past the edge of coping and 75 plf vertical force applied at a distance of 6 inches outside the face of coping over a 30-ft. length of the deck centered with the finishing machine.

**FINISHING-MACHINE LOAD:**

4,500 lbs distributed over 10 ft. along the coping.

**WIND LOAD:**

Designed for 70 mph horizontal wind loading in according with AASHTO LRFD 3.8.1.

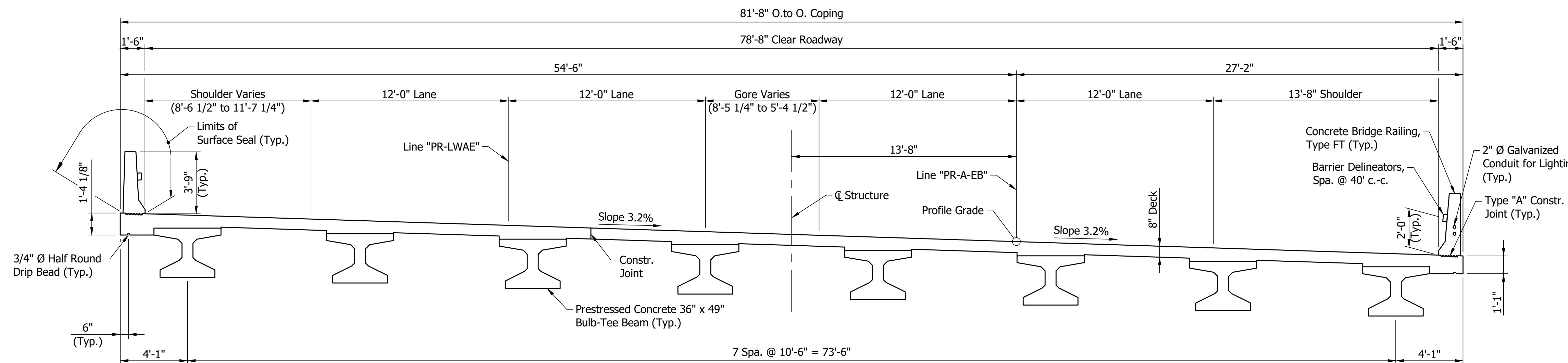

**TYPICAL SECTION**

Scale: 1/4" = 1'-0"

**Note to Reviewer:**

- Seismic Data will be provided at a later submittal when the Geotechnical Investigation is available.
- Surface Seal Quantity to be provided at Stage 3

**COMPOSITE PRESTRESSED CONCRETE BULB-TEE BEAM BRIDGE**  
1 SPAN: 76'-0"  
78'-8" CLEAR ROADWAY SKEW: 0°  
I-64 EB & I-265 WB to I-64 EB RAMP OVER CAPTAIN FRANK ROAD  
FLOYD COUNTY

Notes:  
For Plan & Elevation, see Dwg. C2.  
For Type "A" Construction Joint, see Std.Dwg.No.E702-CJTA-01.

**DRAFT**  
NOT FOR CONSTRUCTION

RECOMMENDED FOR APPROVAL _____	DESIGN ENGINEER _____	DATE _____
DESIGNED: AAM _____	DRAWN: JF _____	
CHECKED: TSW _____	CHECKED: AAM _____	

<b>INDIANA DEPARTMENT OF TRANSPORTATION</b>	
<b>GENERAL PLAN</b>	
<b>TYPICAL SECTION</b>	

HORIZONTAL SCALE	BRIDGE FILE
AS NOTED	164-121-10744
VERTICAL SCALE	DESIGNATION
AS NOTED	2200017
DRAWING NO.	SHEETS
C3 of C7	14 of 26
CONTRACT	PROJECT
R-42570	1900162

PROJECT	DESIGNATION
1900162	2200018
CONTRACT	BRIDGE FILE
R-42570	I64-121-04986 DWBL

STRUCTURE INFORMATION				
STRUCTURE	TYPE	SPAN AND SKEW	OVER	STATION
I64-121-04986 DWBL	CONTINUOUS COMPOSITE PRESTRESSED CONCRETE BULB-TEE	3 SPANS: 72'-2 1/2", 72'-7", & 72'-2 1/2" SKEW: 0°01'33" RT.	CAPTAIN FRANK ROAD	☐ STRUCTURE STA. 2307+89.04 LINE "PR-A-WB"

# INDIANA DEPARTMENT OF TRANSPORTATION

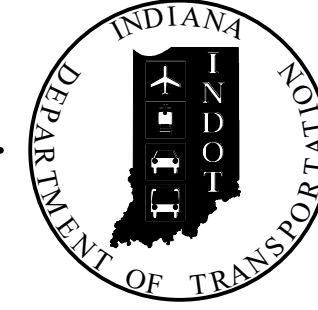

## BRIDGE REHABILITATION PLANS

FOR SPANS OVER 20 FEET  
ROUTE: I-64 WB AT: RP 121+96

PROJECT NO. 2200018 P.E.  
1900162 R/W  
2200018 CONST.

Superstructure Replacement on I-64 WB over Captain Frank Road  
Located 0.29 Miles East of the Junction with I-265 in  
Section 33, T-2-S, R-6-E, New Albany Township, Floyd County, Indiana

TRAFFIC DATA	I-64 MAINLINE	CAPTAIN FRANK RD
A.A.D.T. (2019)	66,980 V.P.D.	6,860 V.P.D.
A.A.D.T. (2046)	84,980 V.P.D.	9,610 V.P.D.
D.H.V. (2046)	8,190 V.P.H.	1,030 V.P.H.
DIRECTIONAL DISTRIBUTION	68 %	50 %
TRUCKS	10 % A.A.D.T.	1 % A.A.D.T.
	6 % D.H.V.	0 % D.H.V.

  

DESIGN DATA		
DESIGN SPEED	70 M.P.H.	
PROJECT DESIGN CRITERIA	NEW CONSTRUCTION (FREEWAY)	NO IMPROVEMENT
FUNCTIONAL CLASSIFICATION	PRINCIPAL ARTERIAL	
RURAL/URBAN	URBAN	
TERRAIN	ROLLING	
ACCESS CONTROL	FULL	

DESIGNATION	PROJECT DESCRIPTION	
ROAD		
1900162	I-64 ATL	LEAD DES.
1900366	US 150 and Old Vincennes Road (East)	
2100019	I-64 Lighting US 150 to I-64 / I-265	
BRIDGE		
1800706	Bridge Painting on US 150 EB over I-64, Str.No. 150-22-04983 AEBL	STR. 1
1800405	Bridge Painting on US 150 EB over I-64, Str.No. 150-22-04983 AWBL	STR. 2
1700207	Bridge Replacement on I-64 EB over Quarry Road, Str.No. I64-120-10786	STR. 3
2200015	Bridge Replacement on I-64 WB over Quarry Road, Str.No. I64-120-10742	STR. 4
1702617	Bridge Replacement on I-64 WB over I-64 EB to I-265 EB Ramp, Str.No. I64-121-10787	STR. 5A
2200016	New Bridge on I-64 EB over I-64 EB Ramp to I-265 EB, Str.No.I64-121-10743 EBL	STR. 5B
1800721	Bridge Replacement on I-64 WB over I-265 WB Ramp to I-64 EB, Str.No.I64-121-10788	STR. 6
2200019	Bridge Replacement on I-265 WB to I-64 EB Ramp over I-64 EB to I-265 EB Ramp, Str.No.(I64)I265-00-10746	STR. 7
2200017	Bridge Replacement on I-64 EB over Captain Frank Road, Str.No.I64-121-10744	STR. 8
2200018	Superstructure Replacement on I-64 WB over Captain Frank Road, Str. No. I64-121-04986 DWBL	STR. 9
1702614	Bridge Deck Overlay on I-64 over Cherry Street, Str.No. I64-122-04988 D	STR. 10
2000326 / 2000323	Bridge Deck Replacement & Widening on I-265 EB & Ramp Over State Street, Str.No. I265-00-05513 JCEB & DRCB	STR. 11
2000324	Bridge Deck Overlay on I-265 WB Over State Street, Str.No. I265-00-05513 DWBL	STR. 12
1700206	Bridge Deck Replacement I-64 EB over SR 62/ SR 64	STR. 13
1700205	Bridge Deck Replacement on I-64 WB over SR 62/ SR 64	STR. 14
2000144	Bridge Deck Overlay on I-64 EB over Yenowine Lane	STR. 15
2000145	Bridge Deck Overlay on I-64 WB over Yenowine Lane	STR. 16
2002072	US 150 EB over Little Indian Creek, Str.No.150-22-05230 CEB	STR. 18
2002073	US 150 WB over Little Indian Creek, Str.No.150-22-05230 CWB	STR. 19
2200719	I-64 EB & WB over SR 62 / Spring Street, Str.No.I64-123-04689 C	STR. 20
2200718	I-64 WB Off-Ramp to Spring Street over I-64 WB On-Ramp from Spring Street, Str.No.I64-123-04688 D	STR. 21
DRAINAGE		
TBD	US 150 Twin Arch Pipe Liner	STR. 17
TBD	Valley View Creek (6 Small Structures and 7 Small Pipe Replacements)	
TBD	Valley View Creek CMP Liner	
TBD	UNT to Little Indian Creek CMP Liner	
TBD	Hill Brook CMP Liner	
TBD	Small Pipes CMP Liners (2)	

BEGIN CONSTRUCTION  
Sta.1025+38.31 Line "PR-U-WB"

BEGIN PROJECT  
Sta.1180+86.02 Line "PR-A-EB"

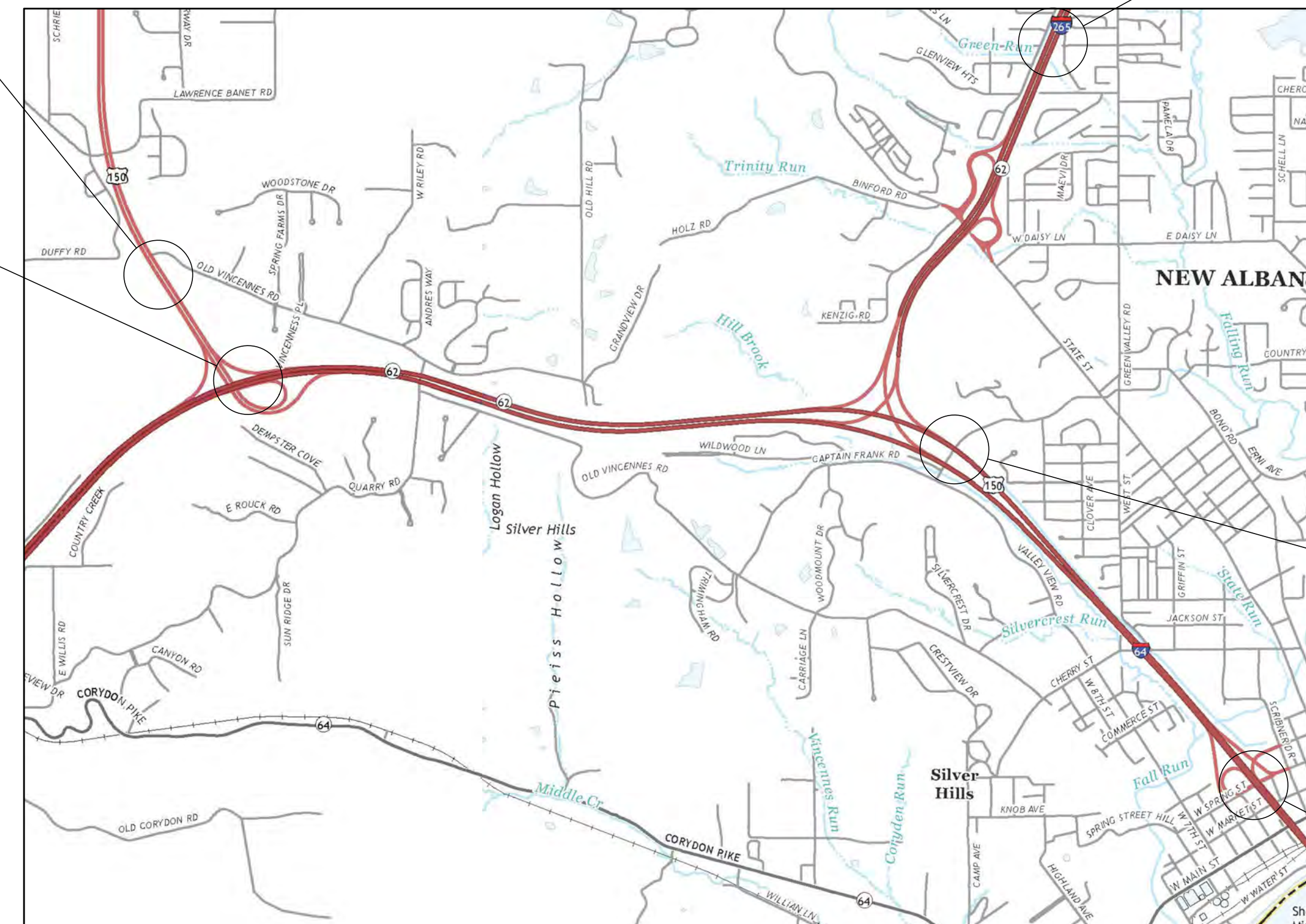

END CONSTRUCTION  
Sta.2077+97.42 Line "PR-L-EB"

STRUCTURE LOCATION  
☐ Str.-Sta.2307+89.04 "PR-A-WB"

END PROJECT  
Sta.1393+50.00 Line "PR-A-EB"

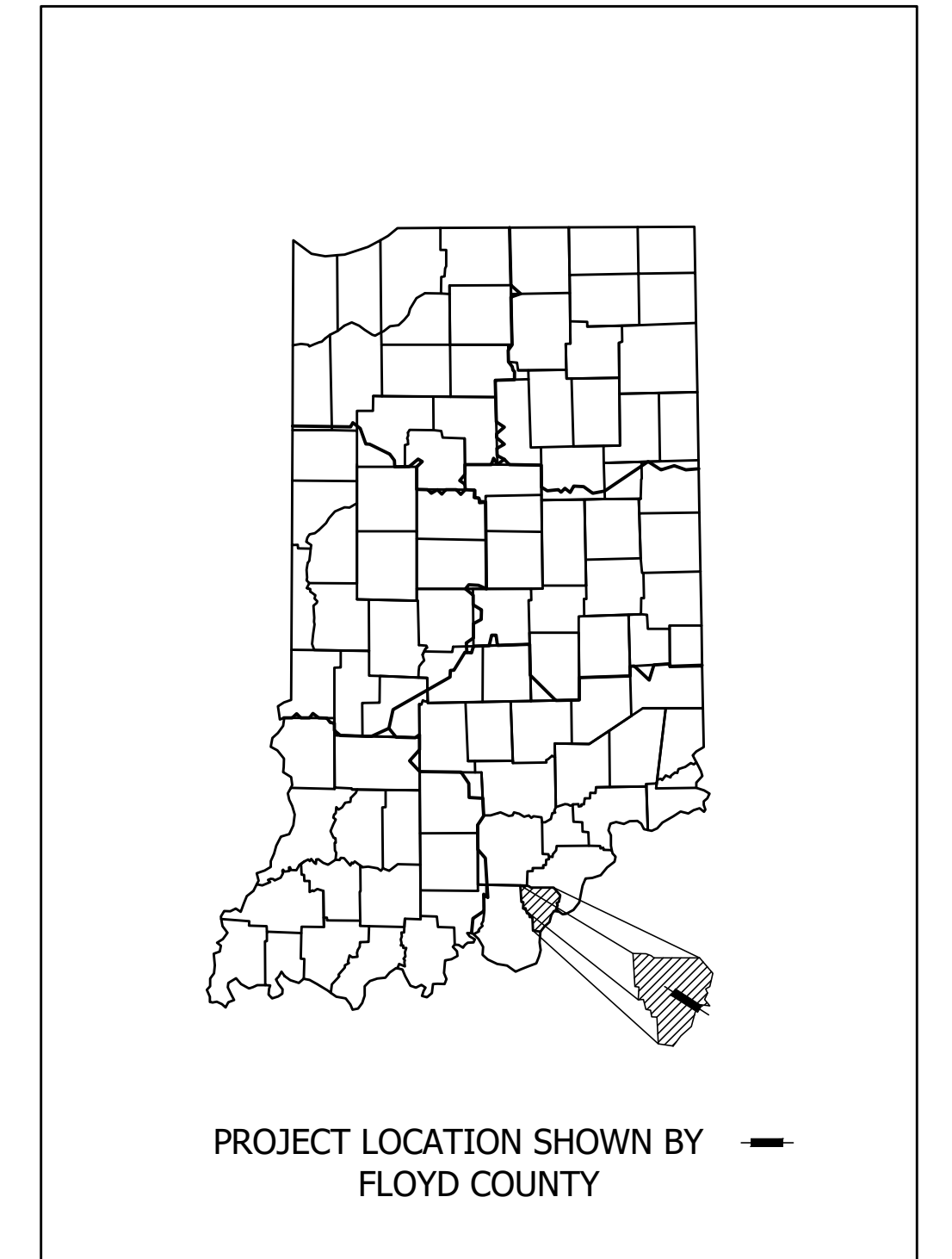

LATITUDE: 38°18'00.97" N LONGITUDE: 85°50'47.29" W

BRIDGE LENGTH: 0.041 MI.  
ROADWAY LENGTH: \* MI.  
TOTAL LENGTH: \* MI.  
MAX. GRADE: 3.00 %

\* SEE DES. NO. 1900162

HUC 12: 051401010904  
HUC 14: 05140101150020

Note to Reviewer:  
The list of Kinned Projects is tentative and subject to change at INDOT Seymour District's direction. This list represents the current understanding of the Contract Package

### STAGE 2 PLANS

PLANS PREPARED BY:  
**BLN**  
BEAM·LONGEST·NEFF  
8320 CRAIG STREET | INDIANAPOLIS, IN 46250  
317.849.5832 | F. 317.841.4280 | WWW.B-L-N.COM

DRAFT  
NOT FOR CONSTRUCTION

PLANS PREPARED BY: BEAM, LONGEST & NEFF, LLC (317)849-5832 PHONE NUMBER  
CERTIFIED BY: \_\_\_\_\_ DATE  
APPROVED FOR LETTING: \_\_\_\_\_ DATE  
INDIANA DEPARTMENT OF TRANSPORTATION

BRIDGE FILE	
164-121-04986 DWBL	
DESIGNATION	
2200018	
DRAWING NO.	SHEETS
	1 of 22
CONTRACT	PROJECT
R-42570	1900162

rstriegel  
 12/5/2022; 7:00:31 PM  
 model: TYP-13 [Sheet]  
 file: p:\i-64\mb\org\Indanapolis\Projects\78704 INDOT-S I-64 ATL\00 CAD-ORD\Sheets\Roadway\1900162\_S\_TYP02.dgn

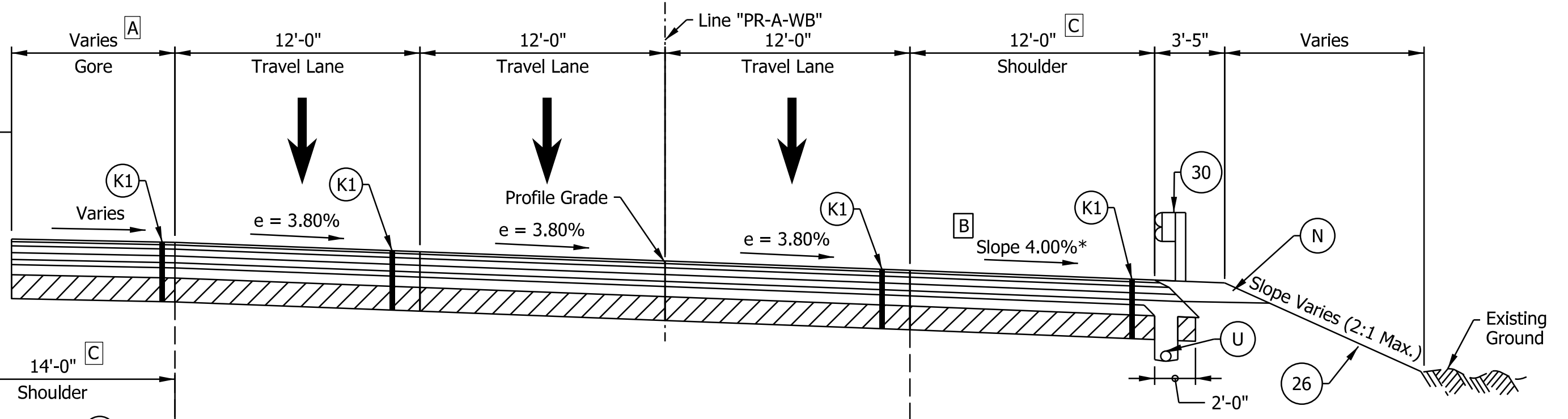

**I-64 WB SUPERELEVATED TYPICAL SECTION**  
 STA. 2280+40.61 "PR-A-WB" TO STA. 2307+00.00 "PR-A-WB"  
 Bridge Paving Exception Sta. 2290+35.66 to Sta. 2293+98.59  
 Bridge Paving Exception Sta. 2295+26.56 to Sta. 2298+20.24  
 Bridge Paving Exception Sta. 2306+56.94 to Sta. 2309+21.16

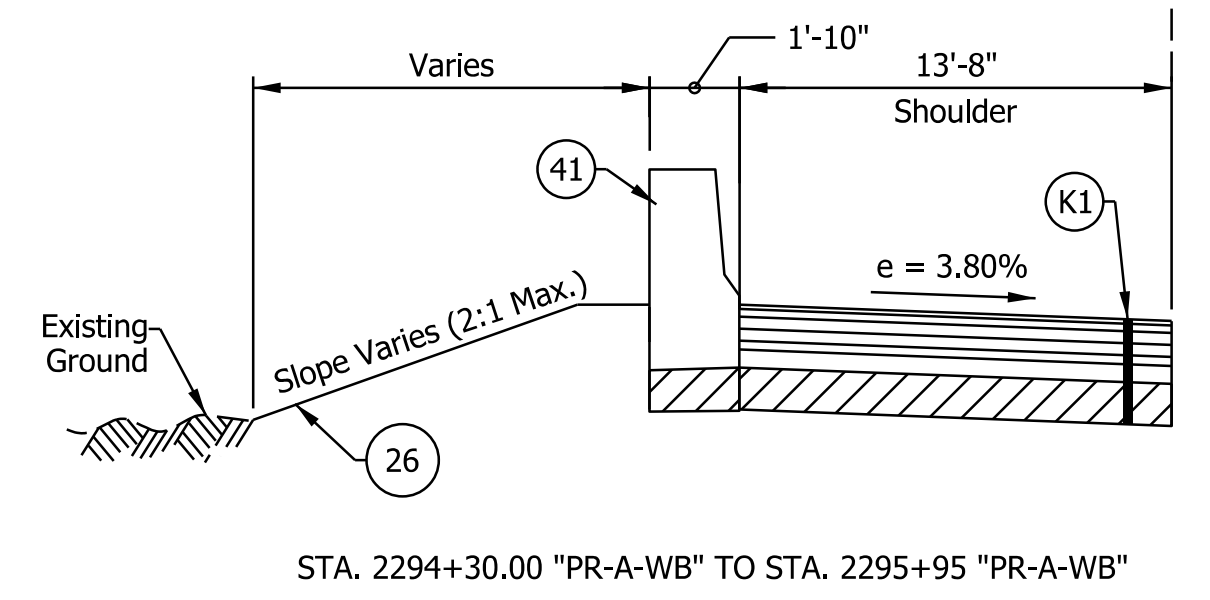
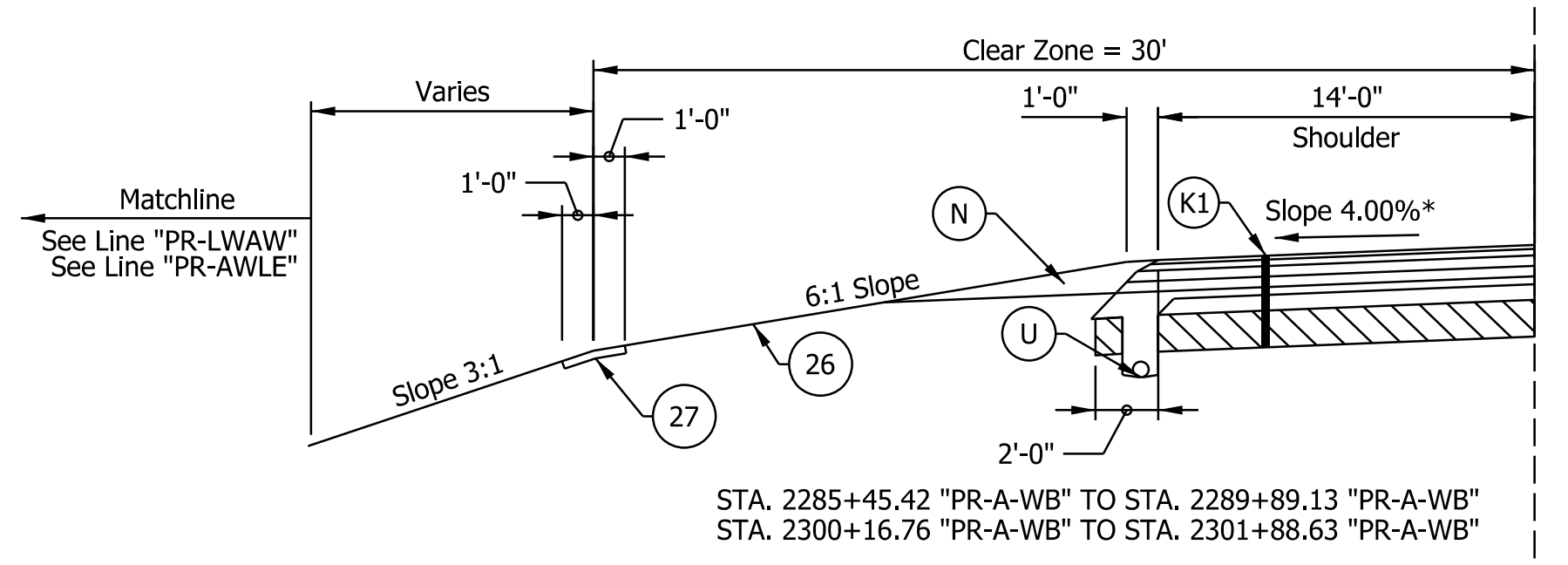
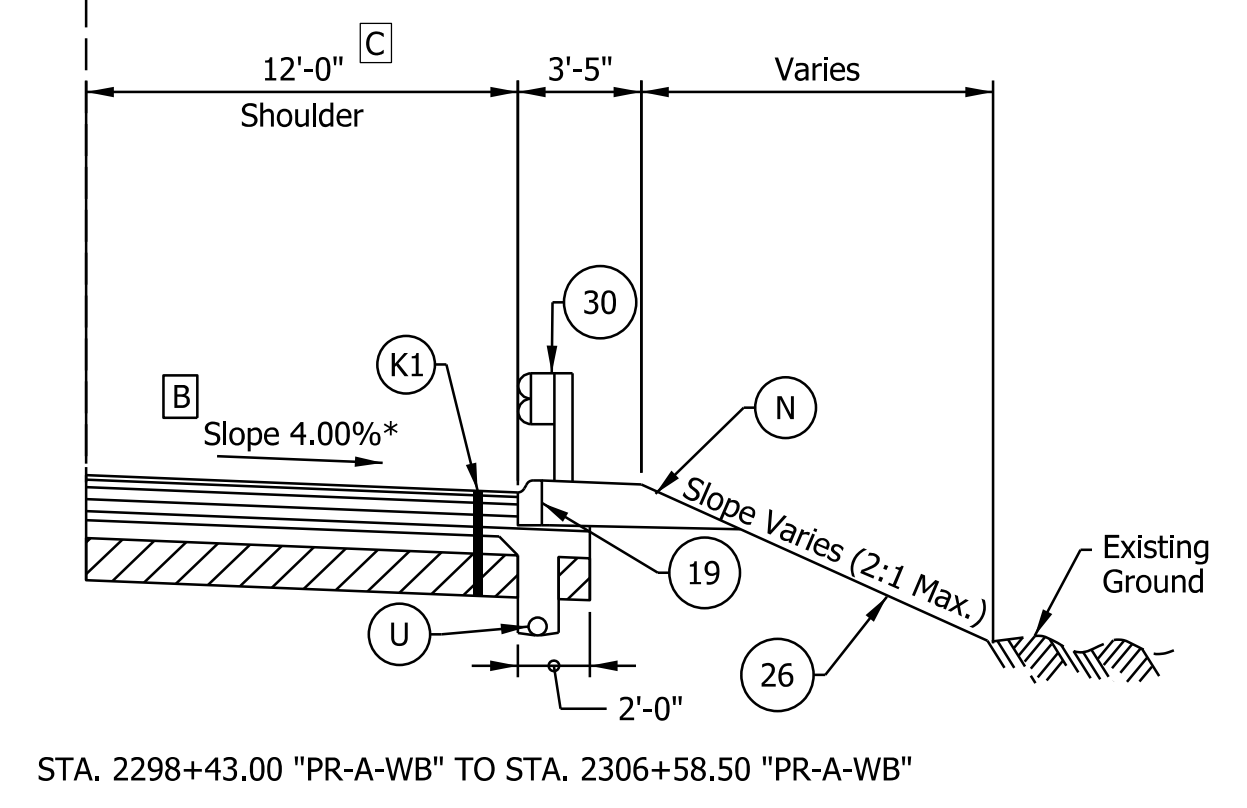
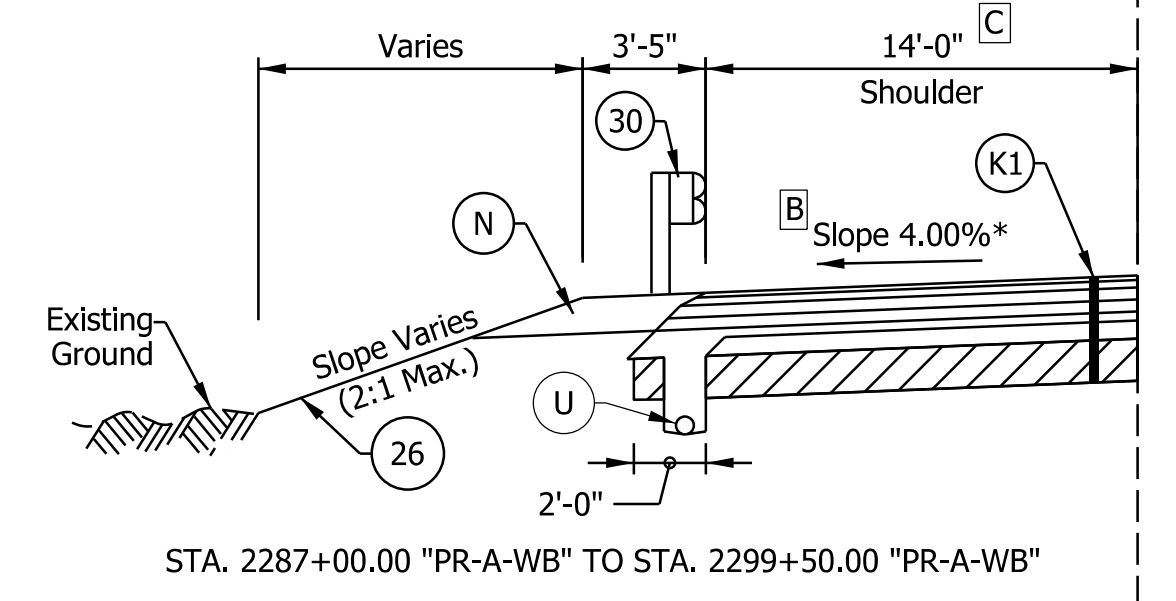

- Notes:
- See Sheet LGD-01 for construction legend
  - See Sheet TS-43 for Safety Edge Details
  - \* Max rollover between shoulder and travel lane not to exceed 8%.
  - A** Gore width varies from 0'-0" at Sta. 2280+40.61 to 25'-0" at Sta. 2285+45.42  
 Gore width varies from 30'-0" at Sta. 2301+88.63 to 0'-0" at Sta. 2306+96.82
  - B** Shoulder slope to rotate to match adjacent lane slope on the bridges over the interior system interchange ramps and Captain Frank Road.
  - C** Right shoulder width shall be 12'-4" from Sta. 2290+12.15 to Sta. 2298+43.00

**FOR INFORMATION ONLY**

**NOTE TO REVIEWER**  
 Coordination with Geotech is in progress.  
 Retaining Wall Details will be  
 Refined in future Submittals

**NOTE TO REVIEWER**  
 2-foot lane extensions at the shoulders will be  
 reviewed and implemented where applicable  
 in a future submittal.

**DRAFT**  
 NOT FOR CONSTRUCTION

RECOMMENDED FOR APPROVAL _____	DESIGN ENGINEER _____	DATE _____
DESIGNED: _____ SGM _____	DRAWN: _____ CGR _____	
CHECKED: _____ ADR _____	CHECKED: _____ ADR _____	

**INDIANA**  
**DEPARTMENT OF TRANSPORTATION**  
  
**I-64 WESTBOUND MAINLINE**  
**PROPOSED TYPICAL SECTIONS**

HORIZONTAL SCALE	BRIDGE FILE
3/16"=1'-0"	N/A
VERTICAL SCALE	DESIGNATION
N/A	1900162
SURVEY BOOK	SHEETS
ELECTRONIC	3 of 22
CONTRACT	PROJECT
R-42570	1900162

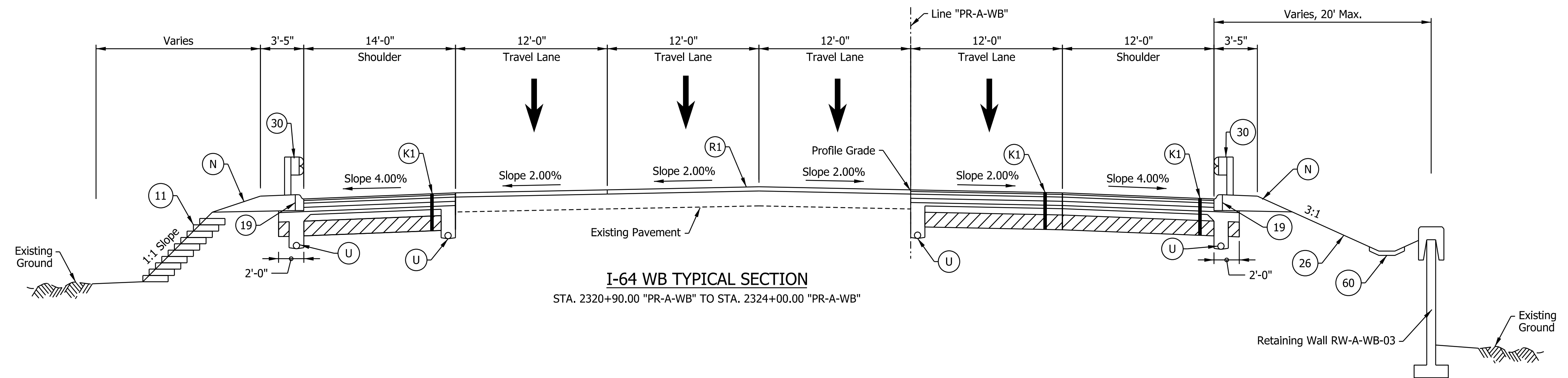
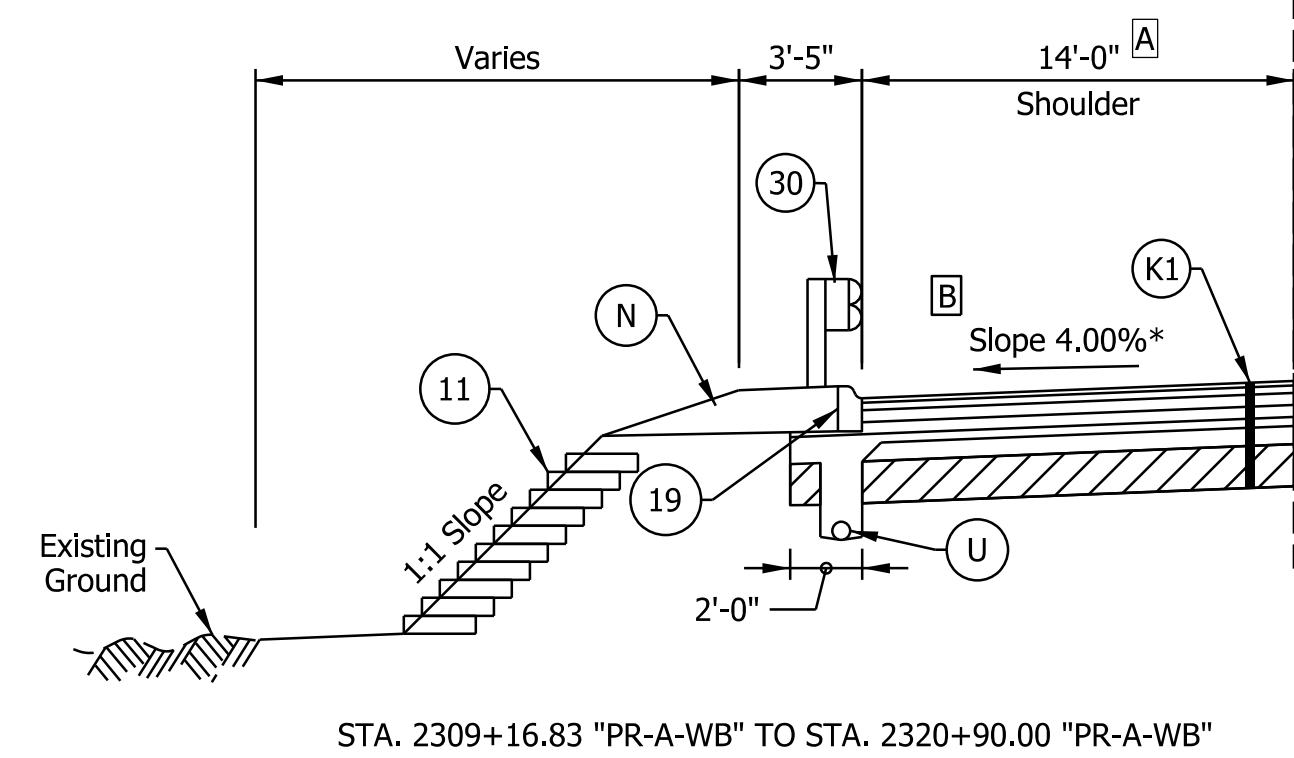
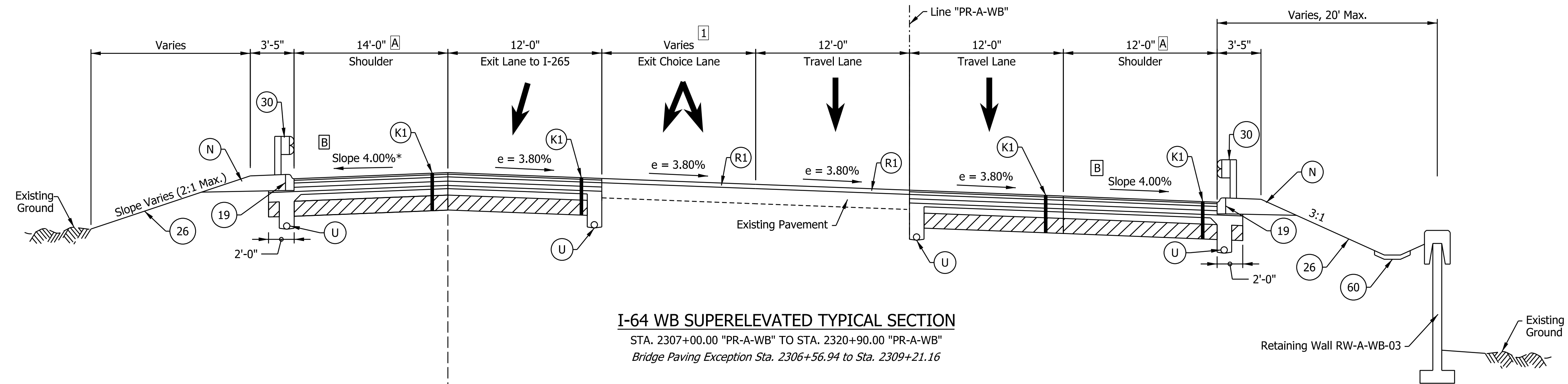

- Notes:
- See Sheet LGD-01 for construction legend
  - See Sheet TS-43 for Safety Edge Details
  - \* Max rollover between shoulder and travel lane not to exceed 8%.
  - A** Left shoulder width varies from 13'-10 7/8" to 15'-9" across the bridge over Captain Frank Road  
Right shoulder width increased to 12'-4" approaching and exiting the bridge over Captain Frank Road
  - B** Shoulder slope to rotate to match adjacent lane slope on the bridges over the interior system interchange ramps and Captain Frank Road.
  - I** Choice lane width varies from 12'-0" at Sta. 2306+96.82 to 0'-0" at Sta. 2317+00.00

**FOR INFORMATION ONLY**

**NOTE TO REVIEWER**  
Coordination with Geotech is in progress.  
Retaining Wall Details will be  
Refined in future Submittals

**NOTE TO REVIEWER**  
2-foot lane extensions at the shoulders will be  
reviewed and implemented where applicable  
in a future submittal.

**DRAFT**  
NOT FOR CONSTRUCTION

RECOMMENDED FOR APPROVAL _____	DESIGN ENGINEER _____	DATE _____
DESIGNED: _____ SGM _____	DRAWN: _____ CGR _____	
CHECKED: _____ ADR _____	CHECKED: _____ ADR _____	

INDIANA  
DEPARTMENT OF TRANSPORTATION

I-64 WESTBOUND MAINLINE  
PROPOSED TYPICAL SECTIONS

HORIZONTAL SCALE	BRIDGE FILE
3/16"=1'-0"	N/A
VERTICAL SCALE	DESIGNATION
N/A	1900162
SURVEY BOOK	SHEETS TS-14
ELECTRONIC	4 of 22
CONTRACT	PROJECT
R-42570	1900162

rstriegel  
 12/05/2022; 7:00:31 PM  
 model: TYP-14 [Sheet]  
 file: p:\i-64\i-64\mtd\p\mgreat\_lakes\Documents\Indianapolis\Projects\78704 INDOT-S I-64 ATL00 CAD-ORD\Sheets\Roadway\1900162\_S\_TYP02.dgn

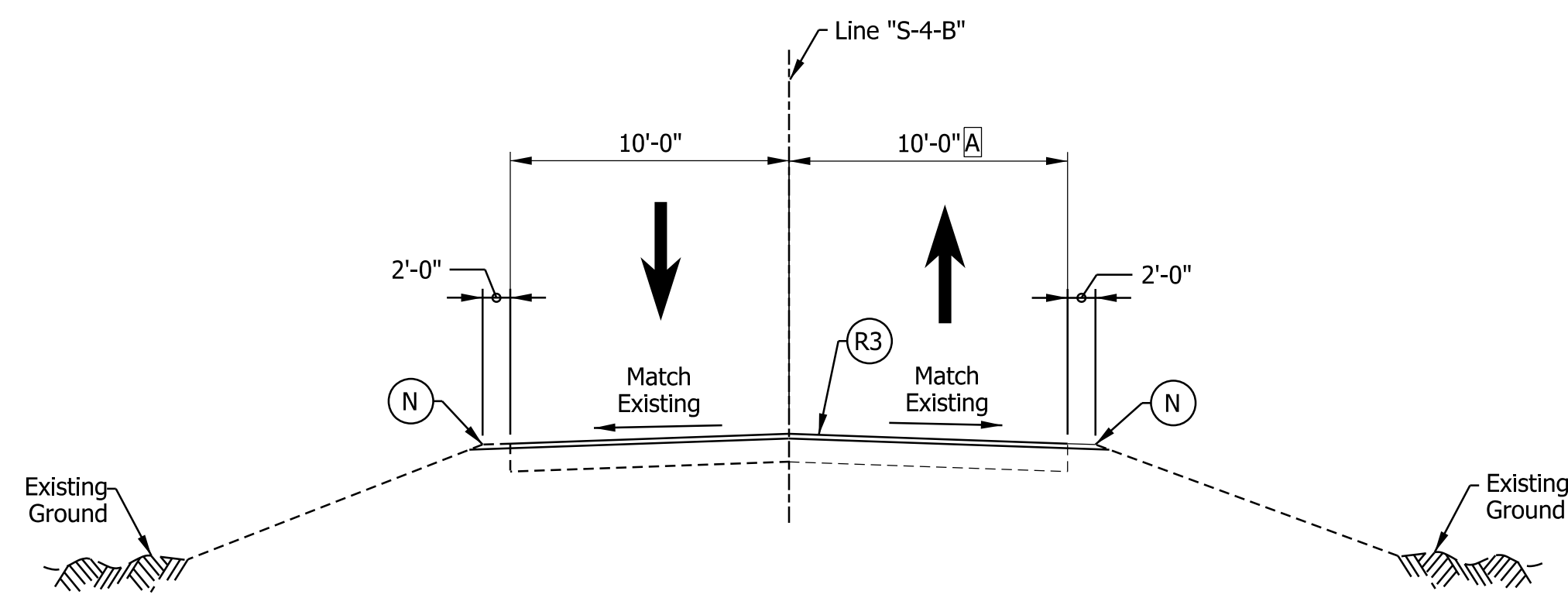

**Captain Frank Road Typical Section**  
 STA. 48+50.00 "S-4-B" TO STA. 54+00.00 "S-4-B"

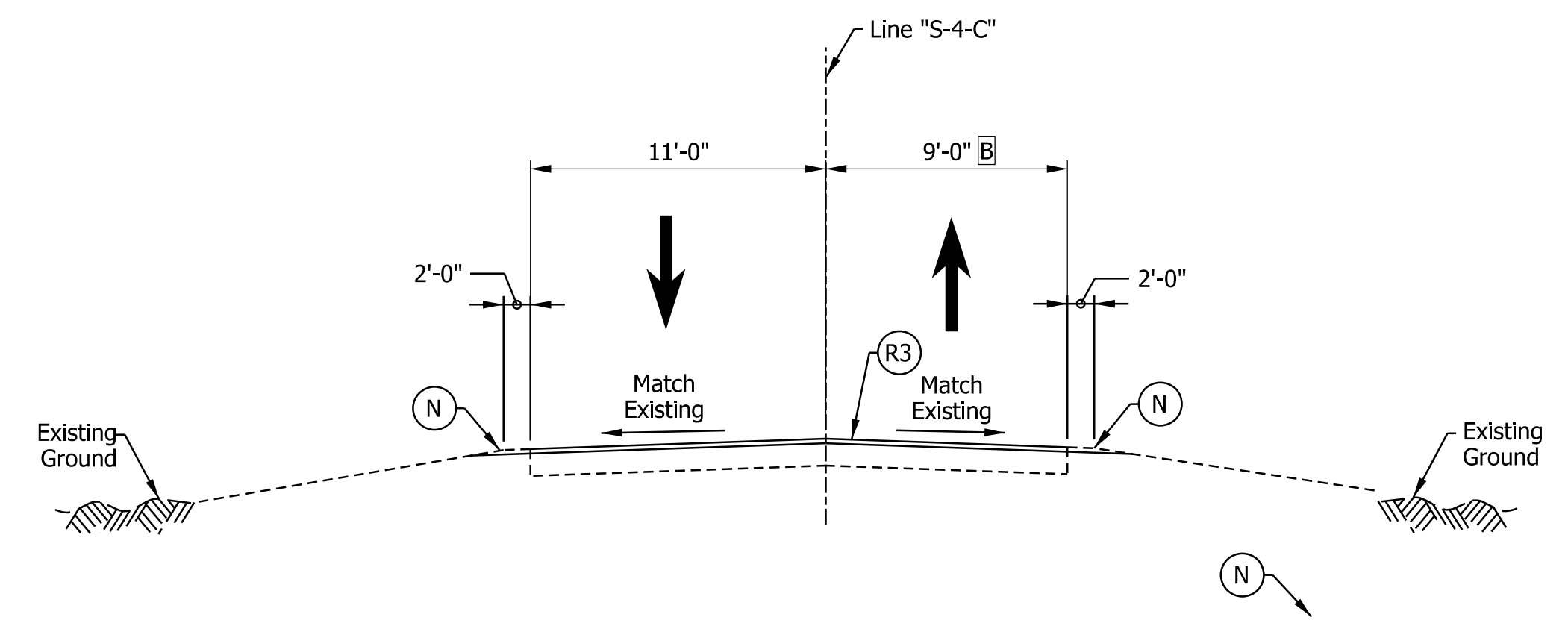

**Quarry Road Typical Section**  
 STA. 47+31.00 "S-4-C" TO STA. 51+70.00 "S-4-C"

**Notes:**

See Sheet LGD-01 for construction legend  
 See Sheet TS-43 for Safety Edge Details

- Ⓐ Northbound Travel Lane is 10'-0" from Sta. 48+50 "S-4-B" to Sta. 52+50 "S-4-B"  
 Northbound Travel Lane Varies from 10'-0" to 11'-6" from Sta. 52+50 "S-4-B" to Sta. 54+00 "S-4-B"
- Ⓑ Northbound Travel Lane Varies from 9'-0" to 14'-6" from Sta. 51+25 "S-4-C" to Sta. 51+70 "S-4-C"

**FOR INFORMATION ONLY**

rstriegel  
 12/5/2022; 7:02:00 PM  
 model: TYP-01 [Sheet]  
 file: p:\i\p\in\hmb\org\INDOT\Projects\78704\INDOT-S-1-64\ATL\00 CAD-ORD\Sheets\Roadway\1900162\_S\_TYP06.dgn

**DRAFT**  
 NOT FOR CONSTRUCTION

RECOMMENDED FOR APPROVAL _____	DESIGN ENGINEER _____	DATE _____
DESIGNED: _____ JKH _____	DRAWN: _____ JKH _____	
CHECKED: _____ ADR _____	CHECKED: _____ ADR _____	

**INDIANA**  
**DEPARTMENT OF TRANSPORTATION**  
  
**QUARRY ROAD / CAPTAIN FRANK ROAD**  
**PROPOSED TYPICAL SECTIONS**

HORIZONTAL SCALE	BRIDGE FILE
3/16"=1'-0"	N/A
VERTICAL SCALE	DESIGNATION
N/A	1900162
SURVEY BOOK	SHEETS
ELECTRONIC	5 of 22
CONTRACT	PROJECT
R-42570	1900162





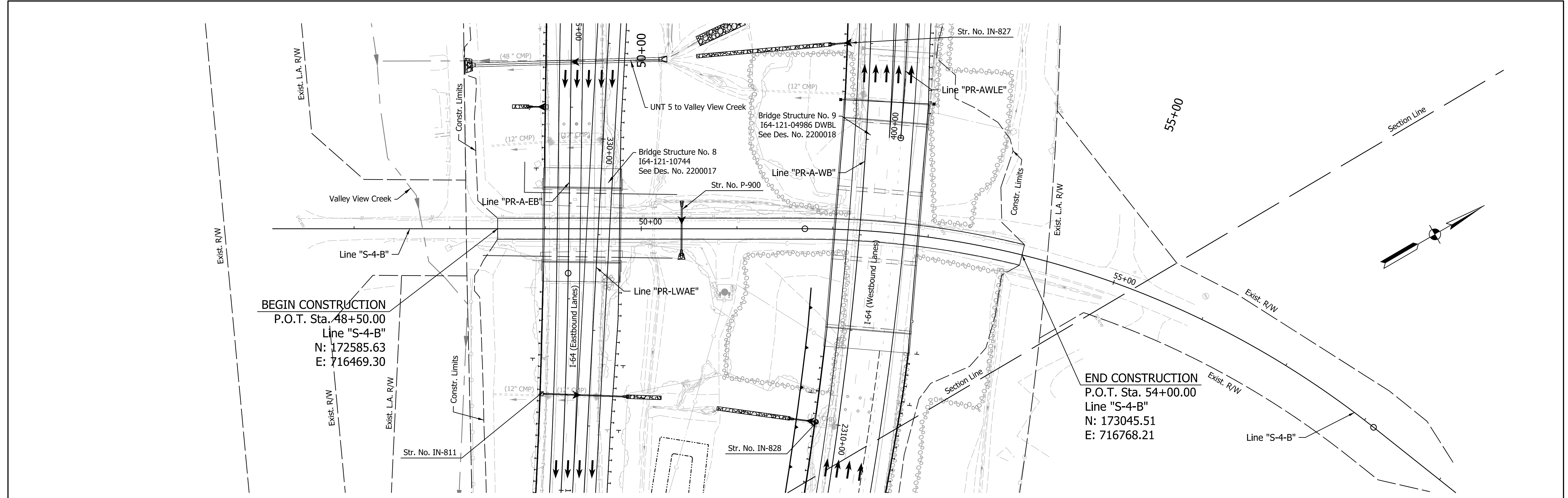

**BEGIN CONSTRUCTION**  
 P.O.T. Sta. 48+50.00  
 Line "S-4-B"  
 N: 172585.63  
 E: 716469.30

**END CONSTRUCTION**  
 P.O.T. Sta. 54+00.00  
 Line "S-4-B"  
 N: 173045.51  
 E: 716768.21

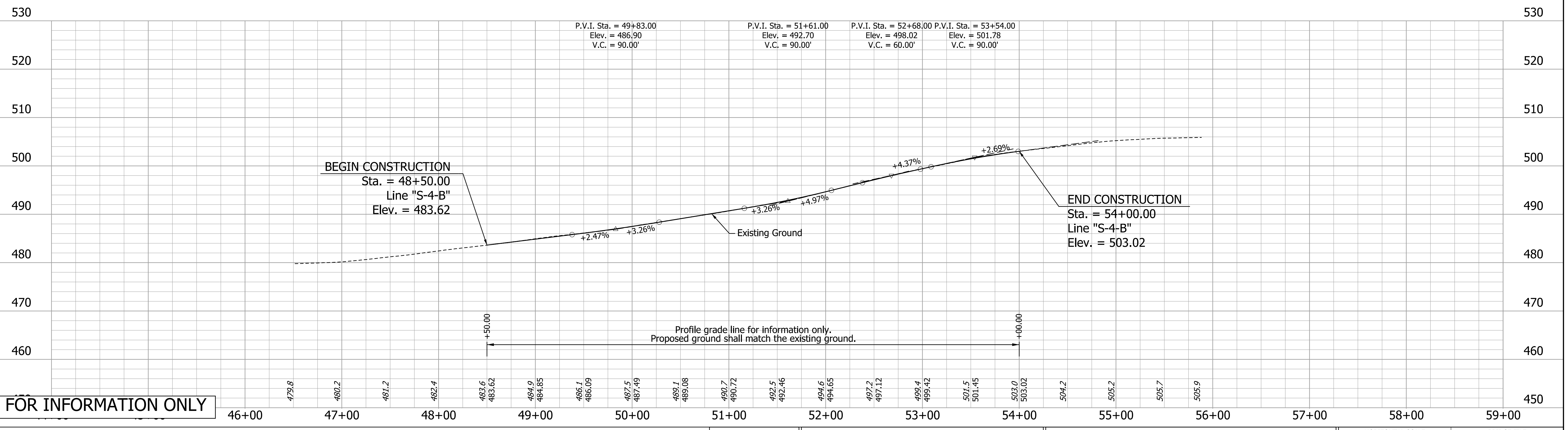

**FOR INFORMATION ONLY**

**DRAFT**  
 NOT FOR CONSTRUCTION

RECOMMENDED FOR APPROVAL \_\_\_\_\_  
 DESIGN ENGINEER \_\_\_\_\_ DATE \_\_\_\_\_  
 DESIGNED: SGM DRAWN: RJS  
 CHECKED: KRC CHECKED: KRC

INDIANA DEPARTMENT OF TRANSPORTATION  
 PLAN SHEET  
 LINE "S-4-B"  
 STA. 48+50 TO STA. 54+00

HORIZONTAL SCALE	BRIDGE FILE
1" = 50'	N/A
VERTICAL SCALE	DESIGNATION
1" = 10'	1900162
SURVEY BOOK	SHEETS
ELECTRONIC	8 of 22
CONTRACT	PROJECT
R-42570	1900162

rstriegel  
 12/5/2022 7:44:04 PM  
 model: PLN-01 [Sheet]  
 file: p:\i\p\in\mb\org\mgreat\_lakes\Documents\Indiana\Projects\78704 INDOT-S I-64 ATL 100 CAD-ORD\Sheets\Roadway\1900162\_S\_PLN20.dgn

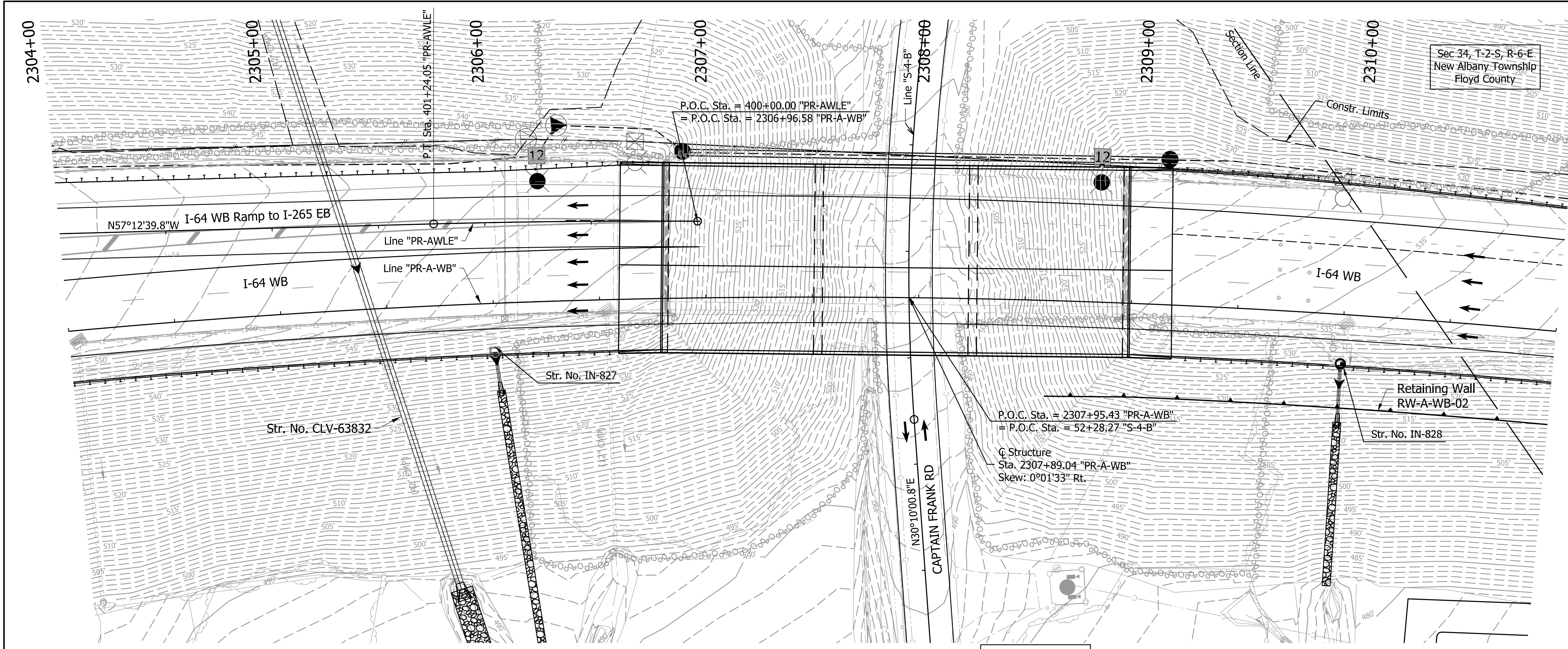

Sec 34, T-2-S, R-6-E  
New Albany Township  
Floyd County

Sec 33, T-2-S, R-6-E  
New Albany Township  
Floyd County

**EXISTING STRUCTURE**  
Existing structure (I64-121-04986 CWBL) is a three-span (72'-0 1/2", 72'-7", & 72'-0 1/2") composite prestressed concrete I-beam bridge with a variable width (62'-2" min.) clear roadway (To Be Rehabilitated).

**EARTHWORK TABULATION**  
For Earthwork Summary, See Road Plans Des. No. 19000162

**HORIZONTAL CURVE DATA FOR LINE "PR-A-WB"**

**CURVE 18**  
P.I. 2303+73.18 "PR-A-WB"  
Δ = 39°07'32.28" RT  
D = 01°30'20.35"  
R = 3805.38'  
T = 1352.25'  
L = 2598.58'  
E = 233.12'  
e = 3.80%

**HORIZONTAL CURVE DATA FOR LINE "S-4-B"**

**CURVE 23**  
P.I. 55+04.16 "S-4-B"  
Δ = 28°28'00.00" RT  
D = 05°59'59.59"  
R = 954.93'  
T = 333.16'  
L = 641.11'  
E = 56.45'  
e = 3.80%

**NOTES:**  
For Reference Ties and Benchmarks, See Road Plans Des. No. 1900162.  
For Ditch Grades & Guardrail Limits, See Plan & Profile Sheet of Road Plans, Des. No. 1900162.  
For existing and proposed utilities, drainage, lighting, signing, and ITS, see Des. No. 1900162.

**CONTINUOUS COMPOSITE PRESTRESSED CONCRETE BULB-TEE BRIDGE**  
3 SPAN: 72'-2 1/2", 72'-7", & 72'-2 1/2"  
86'-6" CLEAR ROADWAY SKEW: 0°01'33" RT.  
I-64 WB OVER CAPTAIN FRANK ROAD  
FLOYD COUNTY

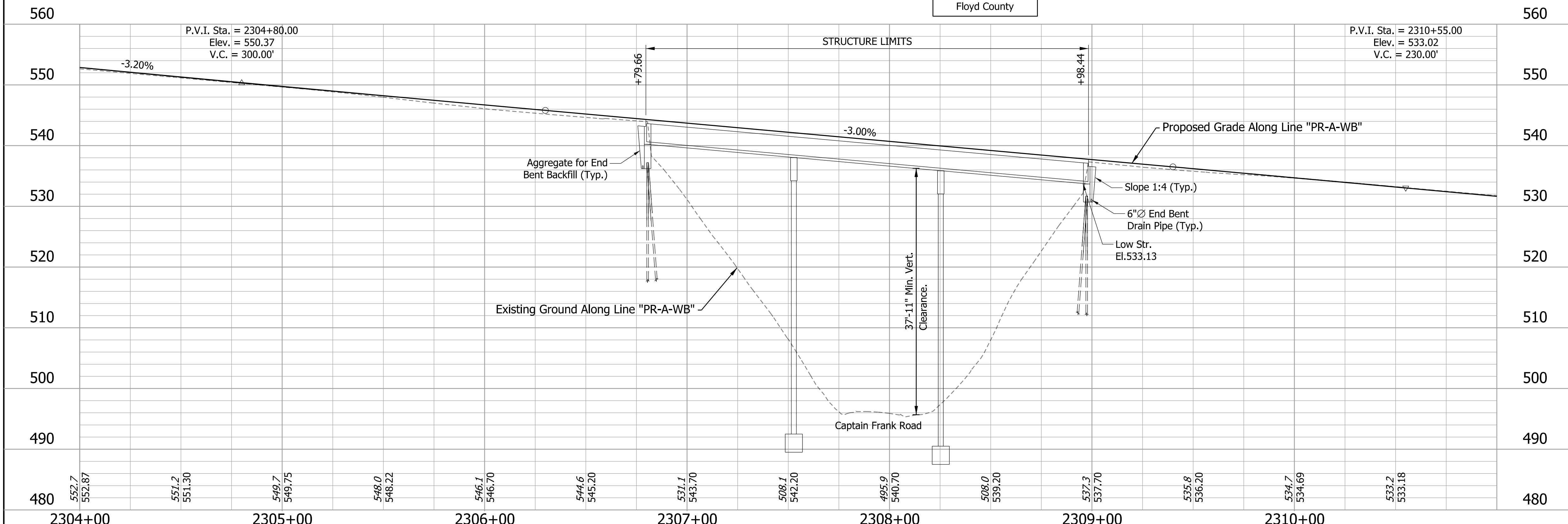

**DRAFT**  
NOT FOR CONSTRUCTION

RECOMMENDED FOR APPROVAL	DESIGN ENGINEER	DATE
DESIGNED: DRT	DRAWN: JP	
CHECKED: TSW	CHECKED: TSW	

INDIANA  
DEPARTMENT OF TRANSPORTATION

LAYOUT - LINE "PR-A-WB"

HORIZONTAL SCALE	BRIDGE FILE
1"=30'	I64-121-04986 DWBL
VERTICAL SCALE	DESIGNATION
1"=10'	2200018
DRAWING NUMBER	SHEETS
C1 of C5	13 of 22
CONTRACT	PROJECT
R-42641	1900162

ssmith  
 12/5/2022; 10:13:01 AM  
 model: PIN-01 [Sheet]  
 file: p:\p\pin-01\mb.org\PM\Great\_Lakes\Documents\Indianapolis Projects\78704 INDOT-S I-64 ATL 00 CAD-ORD\Sheets\Bridges\No. 9 - I-64 WB over Captain Frank Road\1900162\_S\_LAY09.dgn

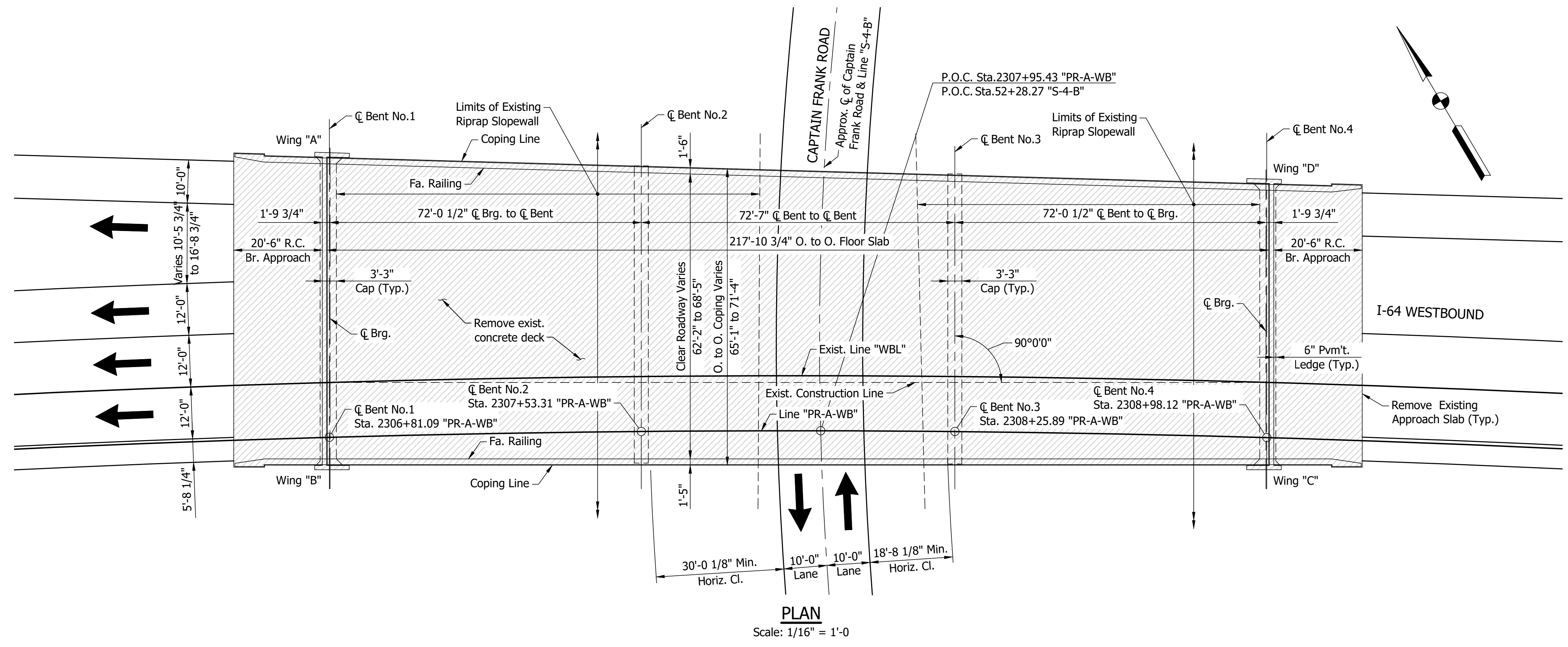
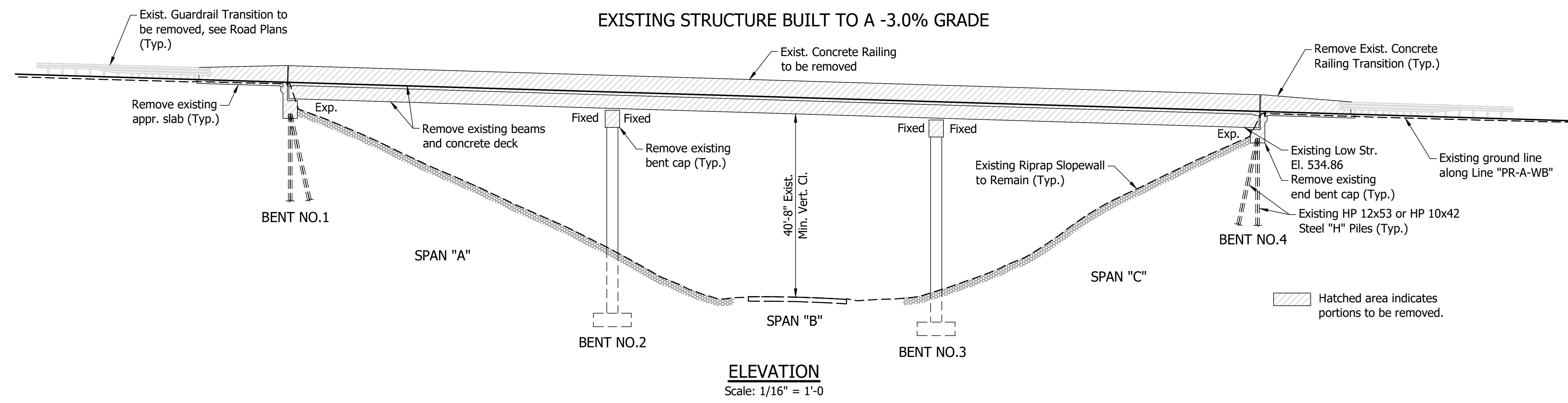

Notes:  
For Typical Section & General Notes, see Dwg. C4.  
For Proposed Plan and Elevation, see Dwg. C3.

COMPOSITE PRESTRESSED CONCRETE TYPE III I-BEAM BRIDGE  
3 SPANS: 72'-0 1/2", 72'-7", & 72'-0 1/2"  
CLEAR ROADWAY VARIES (62'-2" MIN.) SKEW: 0°  
I-64 WB OVER CAPTAIN FRANK ROAD  
FLOYD COUNTY

**DRAFT**  
NOT FOR CONSTRUCTION

RECOMMENDED FOR APPROVAL	DESIGN ENGINEER	DATE
DESIGNED: SJM	DRAWN: JF	
CHECKED: TSW	CHECKED: SJM	

INDIANA  
DEPARTMENT OF TRANSPORTATION

**GENERAL PLAN**  
**EXISTING**

HORIZONTAL SCALE	BRIDGE FILE
1/16" = 1'-0"	164-121-04986 DWBL
VERTICAL SCALE	DESIGNATION
1/16" = 1'-0"	2200018
DRAWING NO.	SHEETS
C2 of C5	14 of 22
CONTRACT	PROJECT
R-42570	1900162

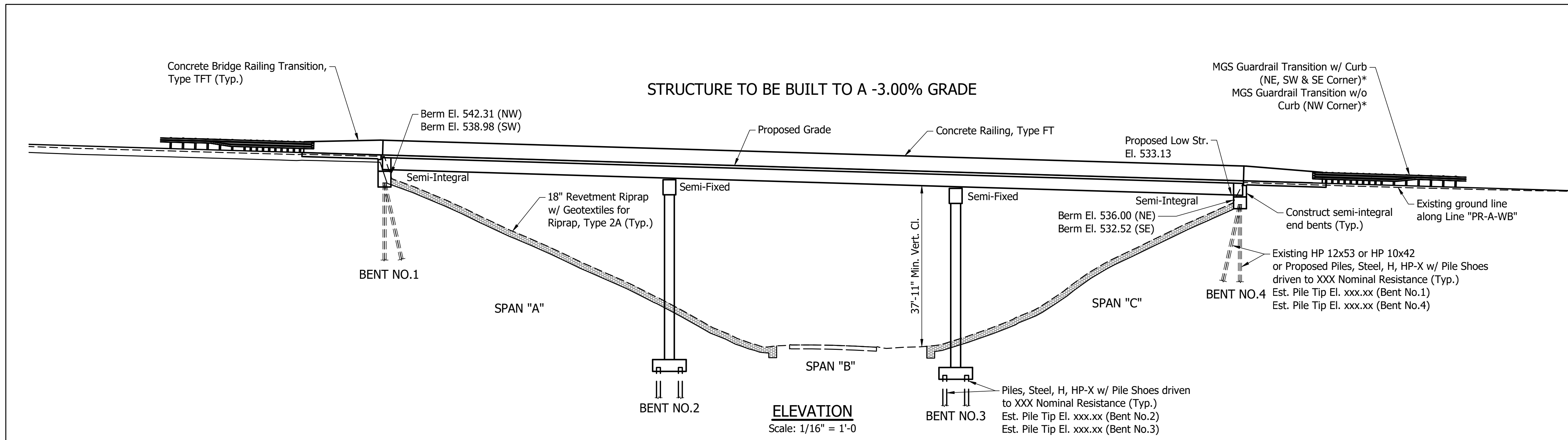

**Note to Reviewer:**

- The Geotechnical Investigation is currently underway. Soil borings, Pile Size and Type will be added at a future submittal.
- The bridge middle ordinate exceeds the 1'-0" shown in IDM Fig 402-6I; however, it is more economical to use a tangent, consistent out-to-out bridge width with parallel beams and constant overhangs. It also better facilitates maintenance of traffic.

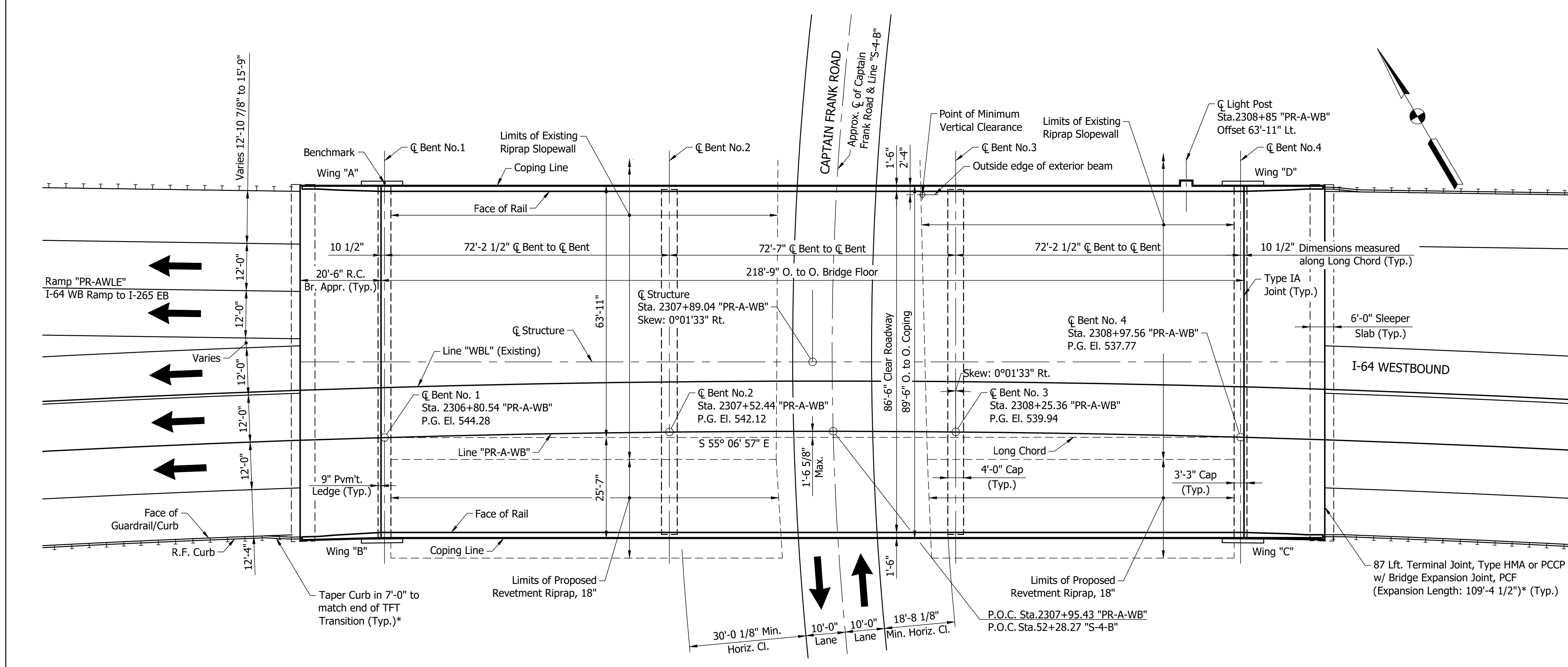

**Notes:**

- For Typical Section & General Notes, see Dwg. C4.
- For Type IA Joint, see Std. Dwg. No. E609-BRJT-01.
- \* Roadway Item

**CONTINUOUS COMPOSITE PRESTRESSED CONCRETE BULB-TEE BEAM BRIDGE**  
3 SPANS: 72'-2 1/2", 72'-7", & 72'-2 1/2"  
86'-6" CLEAR ROADWAY SKEW: 0°01'33" RT.  
I-64 WB OVER CAPTAIN FRANK ROAD  
FLOYD COUNTY

<b>DRAFT</b> NOT FOR CONSTRUCTION	RECOMMENDED FOR APPROVAL _____	DESIGN ENGINEER _____ DATE _____	INDIANA DEPARTMENT OF TRANSPORTATION	HORIZONTAL SCALE 1/16" = 1'-0"	BRIDGE FILE 164-121-04986 DWBL
	DESIGNED: SJM	DRAWN: JF	GENERAL PLAN	VERTICAL SCALE 1/16" = 1'-0"	DESIGNATION 2200018
	CHECKED: TSW	CHECKED: SJM	PROPOSED	DRAWING NO. C3 of C5	SHEETS 15 of 22
				CONTRACT R-42570	PROJECT 1900162

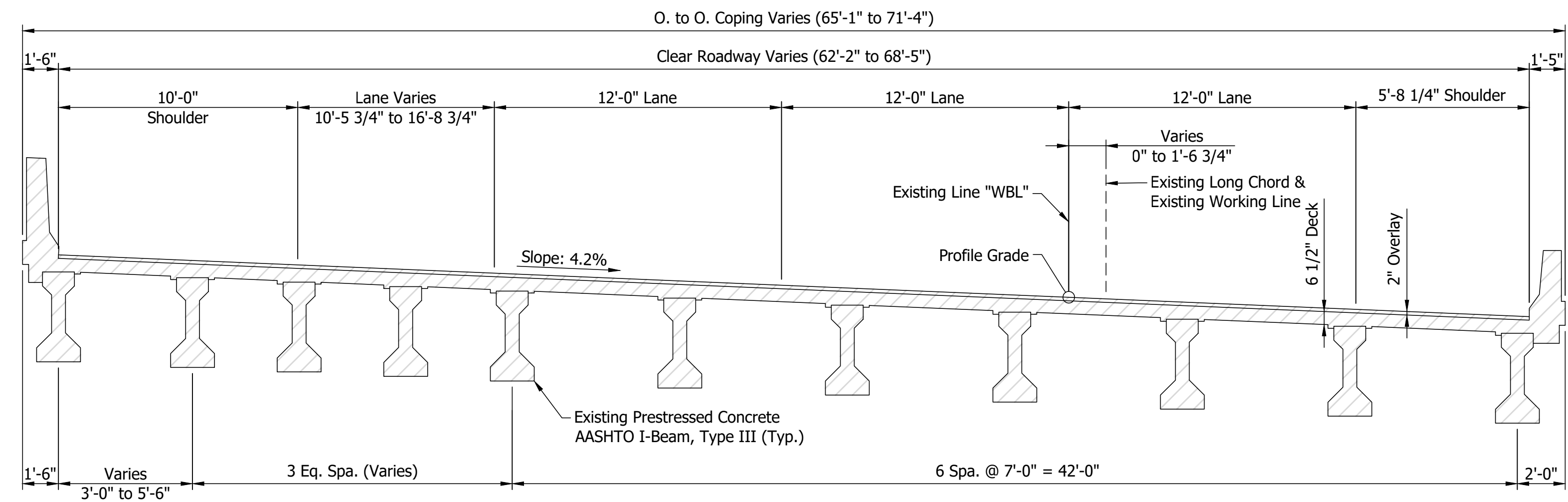

**EXISTING TYPICAL SECTION**  
Scale: 1/4" = 1'-0"

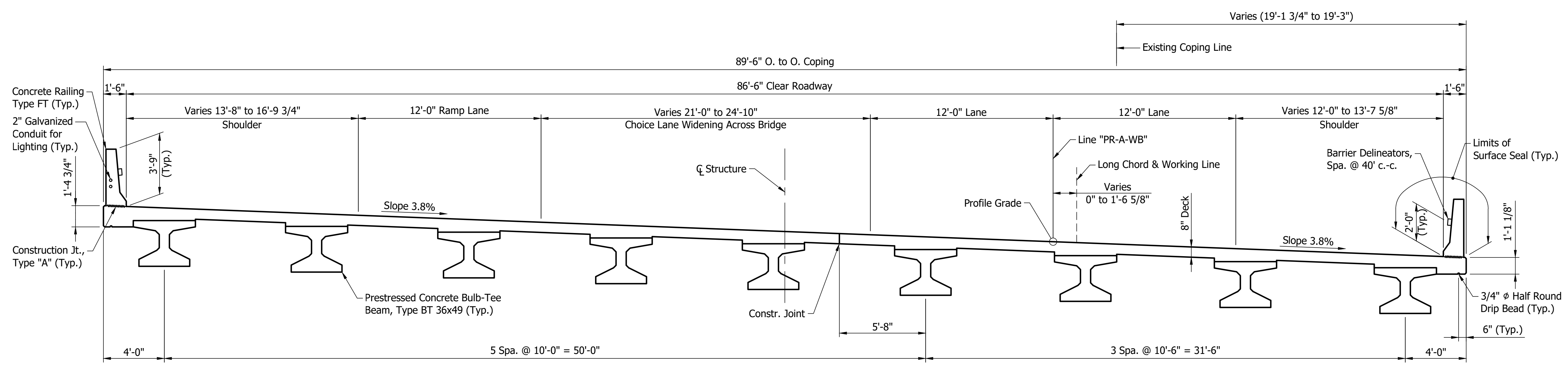

**PROPOSED TYPICAL SECTION**  
Scale: 1/4" = 1'-0"

**Note to Reviewer:**

- Seismic Data will be provided at a later submittal when the Geotechnical Investigation is available.
- Geotextile Type to be provided when Geotechnical Report is complete
- Surface Seal Quantity to be provided at Stage 3
- Stakeout Diagram to be provided at Stage 3

**Notes:**

- Hatched area indicates portions to be removed.
- For Existing Plan & Elevation, see Dwg. C2.
- For Proposed Plan & Elevation, see Dwg. C3.
- For Type "A" Construction Joint, see Std.Dwg.No.E702-CJTA-01.

**GENERAL NOTES**

Reinforcing bar covering shall be 2 1/2" in top and 1" minimum in the bottom of the floor slab, 3" in footings except for bottom bars which shall be 4" and 2" in all other parts, unless otherwise noted.

Reinforcing bars in deck, barrier, and bent diaphragms and end bent caps shall be epoxy coated, unless otherwise noted.

The concrete bridge railings, concrete railing transitions and all exposed surfaces of wings and end bents to be sealed in accordance with Article 702.21 of the Specifications.  
(Estimated Quantity = XXXX Sft.)

**DESIGN DATA**

**LIVE LOAD**  
Designed for HL-93 loading, in accordance with the AASHTO LRFD Bridge Design Specifications, Eighth Edition, 2017.

**DEAD LOAD**  
Actual weight plus 35 psf (composite) for future wearing surface and 15 psf (non-composite) for permanent metal deck forms.

**FLOOR SLAB**  
Designed with 7 1/2" structural depth plus 1/2" sacrificial wearing surface.

**DESIGN STRENGTHS**  
To be in accordance with AASHTO LRFD Bridge Design Specifications, Eighth Edition, 2017.

**PRESTRESSED CONCRETE, NORMAL WEIGHT:**  
f<sub>c</sub>=8,000 psi @ 28 days  
Initial f<sub>c</sub>=5,000 psi @ Release of Strands

**PRESTRESSING STRANDS:**  
0.6" Ø 7 Wire LoLax Strands (A<sub>s</sub>=0.217 in<sup>2</sup>)  
Min. Tensile Strength=270,000 psi  
Initial Pull=43,940 lbs. per strand

**CONCRETE:**  
Class "A": f<sub>c</sub>=3,500 psi  
Class "B": f<sub>c</sub>=3,000 psi  
Class "C": f<sub>c</sub>=4,000 psi

**REINFORCING BARS:**  
Grade 60: F<sub>y</sub>=60,000 psi

**SEISMIC DATA**  
AASHTO Guide Specifications for LRFD Seismic Bridge Design  
Seismic Zone X  
S1 = X.XX  
Site Class X  
F<sub>v</sub> = X.XX

**CONSTRUCTION LOADING**  
The exterior beams have been checked for strength, deflection, and overturning using the construction loads shown below. Cantilever overhang brackets were assumed for support of the deck overhang past the edge of exterior beam. The finishing machine was assumed to be supported 6 inches outside the vertical coping form. The top overhang brackets were assumed to be located 6 inches past the edge of the vertical coping form. The bottom overhang brackets were assumed to be braced against the intersection of the beam bottom flange and web.

**DECK FALSEWORK LOADS:**  
Designed for 15 psf for permanent metal stay-in-place deck forms, removable deck forms, and 2-ft. exterior walkway.

**CONSTRUCTION LIVE LOAD:**  
Designed for 20 psf extending 2 ft. past the edge of coping and 75 plf vertical force applied at a distance of 6 inches outside the face of coping over a 30-ft. length of the deck centered with the finishing machine.

**FINISHING-MACHINE LOAD:**  
4,500 lbs distributed over 10 ft. along the coping.

**WIND LOAD:**  
Designed for 70 mph horizontal wind loading in according with AASHTO LRFD 3.8.1.

CONTINUOUS COMPOSITE PRESTRESSED CONCRETE BULB-TEE BEAM BRIDGE  
3 SPANS: 72'-2 1/2", 72'-7", & 72'-2 1/2"  
86'-6" CLEAR ROADWAY SKEW: 0°01'33" RT.  
I-64 WB OVER CAPTAIN FRANK ROAD  
FLOYD COUNTY

<b>DRAFT</b> NOT FOR CONSTRUCTION	RECOMMENDED FOR APPROVAL _____	DESIGN ENGINEER _____ DATE _____	<b>INDIANA</b> <b>DEPARTMENT OF TRANSPORTATION</b>	HORIZONTAL SCALE	BRIDGE FILE
	DESIGNED: SJM	DRAWN: JF		1/4" = 1'-0"	164-121-04986 DWBL
	CHECKED: TSW	CHECKED: SJM		VERTICAL SCALE	DESIGNATION
				1/4" = 1'-0"	2200018
			<b>GENERAL PLAN</b> <b>TYPICAL SECTIONS</b>	DRAWING NO.	SHEETS
				C4 of C5	16 of 22
				CONTRACT	PROJECT
				R-42570	1900162

PROJECT	DESIGNATION
1900162	1702614
CONTRACT	BRIDGE FILE
R-42570	164-122-04988 D

STRUCTURE INFORMATION				
STRUCTURE	TYPE	SPAN AND SKEW	OVER	STATION
I64-122-04988 D	PRESTRESSED CONCRETE I-BEAM BRIDGE	3 SPANS: 52'-11", 86'-11 1/2", 52'-11" SKEW: 41°55'00" RT.	CHERRY STREET	C. STRUCTURE STA. 1354+04.03 "PR-A-EB" C. STRUCTURE STA. 2355+85.98 "PR-A-WB"

# INDIANA DEPARTMENT OF TRANSPORTATION

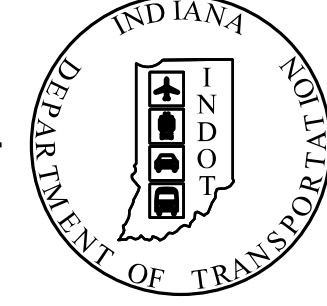

## BRIDGE PREVENTIVE MAINTENANCE PLANS

FOR SPANS OVER 20 FEET

ROUTE : I-64 AT: RP 122+49

PROJECT NO. 1702614 P.E.  
1900162 R/W  
1702614 CONST.

TRAFFIC DATA	I-64 MAINLINE	CHERRY STREET
A.A.D.T. (2019)	66,980 V.P.D.	5,180 V.P.D.
A.A.D.T. (2046)	84,980 V.P.D.	6,880 V.P.D.
D.H.V (2046)	8,190 V.P.H.	720 V.P.H.
DIRECTIONAL DISTRIBUTION	68%	54%
TRUCKS	10%	2%
	6% D.H.V.	1% D.H.V.

DESIGN DATA		
DESIGN SPEED	70 M.P.H.	
PROJECT DESIGN CRITERIA	4R (FREEWAY)	NO IMPROVEMENT
FUNCTIONAL CLASSIFICATION	INTERSTATE	
RURAL/URBAN	URBAN	
TERRAIN	ROLLING	
ACCESS CONTROL	FULL	

KIN PROJECT INFORMATION		
DESIGNATION	PROJECT DESCRIPTION	
ROAD		
1900162	Added Travel Lanes on I-64	LEAD DES.
1900366	US 150 and Old Vincennes Road (East)	
2100019	I-64 Lighting US 150 to I-64 / I-265	
BRIDGE		
1800706	Bridge Painting on US 150 EB over I-64	Str. 1
1800405	Bridge Painting on US 150 WB over I-64	Str. 2
1700207	Bridge Replacement on I-64 EB over Quarry Road	Str. 3
2200015	Bridge Replacement on I-64 WB over Quarry Road	Str. 4
1702617	Bridge Replacement on I-64 WB over I-64 Ramp to I-265 EB	Str. 5A
2200016	Bridge Replacement on I-64 EB over I-64 Ramp to I-265 EB	Str. 5B
1800721	Bridge Replacement on I-64 WB over I-265 Ramp to I-64 EB	Str. 6
2200019	Bridge Replacement on I-265 WB to I-64 EB over I-64 EB to I-265 EB	Str. 7
2200017	Bridge Replacement on I-64 EB over Captain Frank Road	Str. 8
2200018	Superstructure Replacement on I-64 WB over Captain Frank Road	Str. 9
1702614	Bridge Deck Overlay on I-64 EB & WB over Cherry Street	Str. 10
2000326 / 2000323	Bridge Deck Replacement and Widening on I-265 EB over State Street	Str. 11
2000324	Bridge Deck Overlay on I-265 WB over State Street	Str. 12
1700205	I-64 WB over SR62 / SR 64	Str. 14
1700206	I-64 EB over SR62 / SR 64	Str. 13
2000144	Bridge Deck Overlay on I-64 EB over Yenowine Lane	Str. 15
2000145	Bridge Deck Overlay on I-64 WB over Yenowine Lane	Str. 16
2002072	US 150 EB over Little Indian Creek	Str. 18
2002073	US 150 WB over Little Indian Creek	Str. 19
2200719	I-64 EB & WB over SR 62 / Spring Street	Str. 20
2200718	I-64 WB Off-Ramp to Spring over I-64 WB On-Ramp from Spring	Str. 21
DRAINAGE		
TBD	US 150 Twin Arch Pipe Liner	Str. 17
TBD	Valley View Creek (6 Small Structure and 7 Small Pipe Replacements)	
TBD	Valley View Creek CMP Liner	
TBD	UNT to Little Indian Creek CMP Liner	
TBD	Hill Brook CMP Liner	
TBD	Small Pipes CMP Liners (2)	

BRIDGE DECK OVERLAY ON I-64 OVER CHERRY STREET  
LOCATED 0.85 MILES WEST OF SR 111 IN  
SECTION 34, T-2-S, R-6-E, NEW ALBANY TOWNSHIP, FLOYD COUNTY, INDIANA

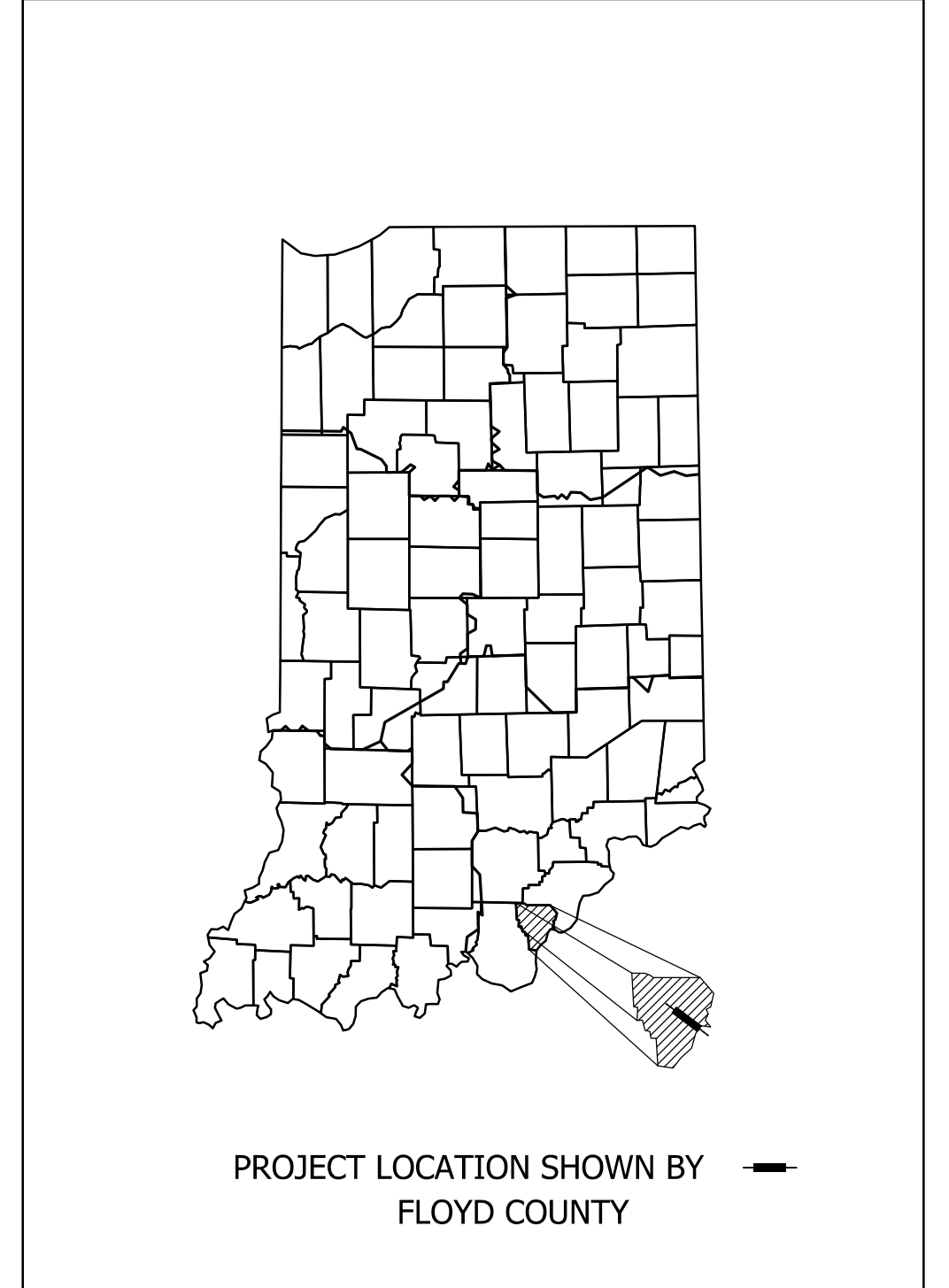
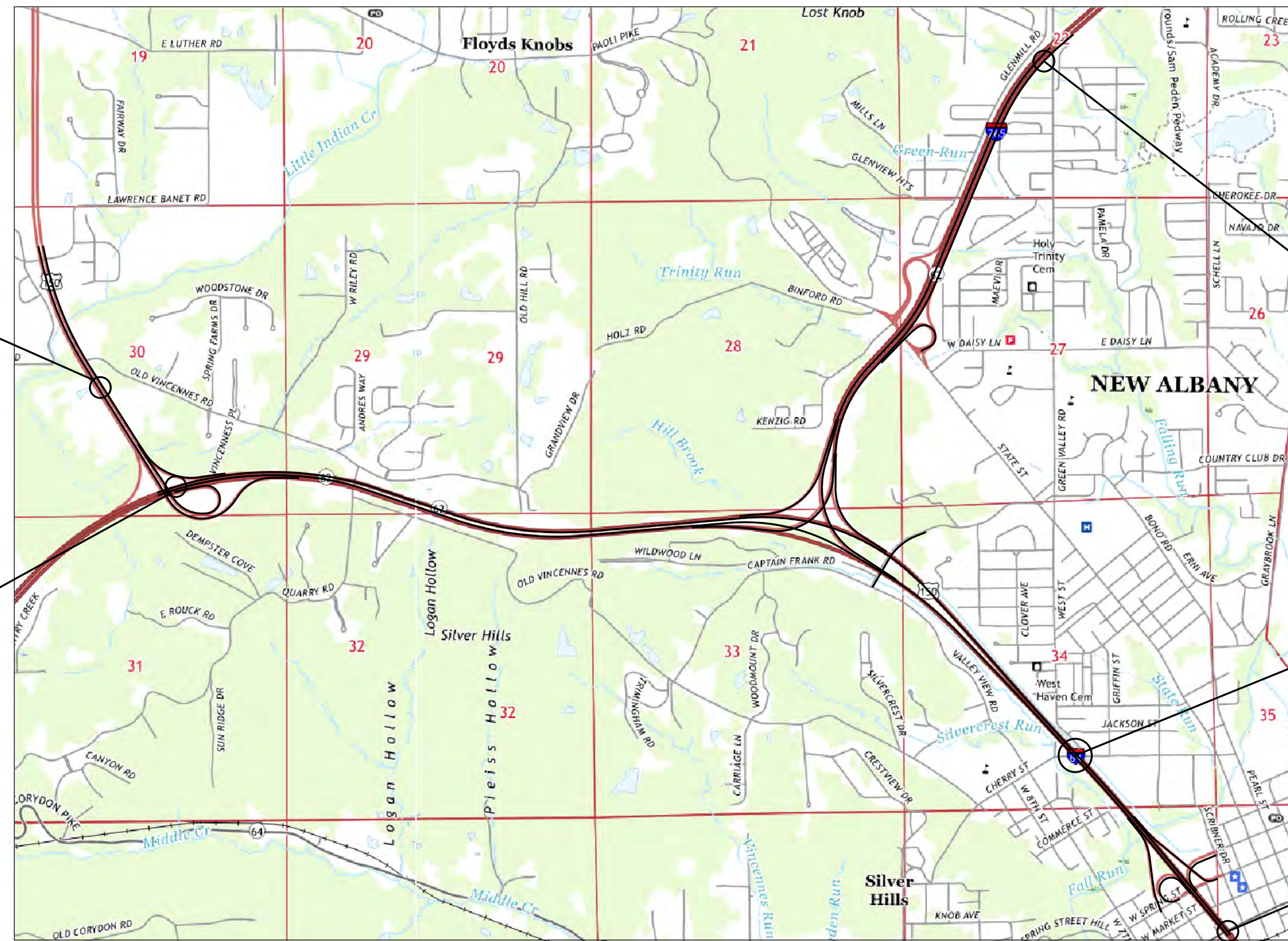

LATITUDE: 38°17'26.7" N LONGITUDE: 85°50'06.4" W

BRIDGE LENGTH: 0.038 MI.  
ROADWAY LENGTH: \* MI.  
TOTAL LENGTH: \* MI.  
MAX. GRADE: 0.5 %  
\* SEE DES NO. 1900162

12-DIGIT HYDROLOGIC UNIT CODE: 051401010904

**NOTE TO REVIEWER**  
The list of KIN'd projects is tentative and subject to change at INDOT Seymour District's direction. This list represents the current understanding of the contract package.

**STAGE 2 PLANS**



9102 North Meridian Street, Suite 200, Indianapolis, IN 46260  
Phone: (317) 566-0629

**DRAFT**  
NOT FOR CONSTRUCTION

PLANS PREPARED BY:	SJCA, INC	(317) 566-0629
CERTIFIED BY:		DATE
RECOMMENDED FOR LETTING:		DATE

INDIANA DEPARTMENT OF TRANSPORTATION

INDIANA DEPARTMENT OF TRANSPORTATION  
STANDARD SPECIFICATIONS DATED 2022  
TO BE USED WITH THESE PLANS

BRIDGE FILE		
164-122-04988 D		
DESIGNATION		
1702614		
SURVEY BOOK	SHEETS	TTL-01
ELECTRONIC	1 of 14	
CONTRACT	PROJECT	
R-42570	1900162	

khamison 12/5/2022 1:11:02 PM model: TTL-01 [Sheet] file: p:\i\p\i\hmb\org\PM\Great\_Lakes\Documents\Indianapolis\Projects\78704 INDOT-S I-64 ATL 00 CAD-ORD\Sheets\Bridge\Bridge No. 104 - I-64 EB over Cherry St\1702614\_S\_TTL01.dgn

khamison  
 12/5/2022; 1:11:16 PM  
 model: TYP-01 [Sheet]  
 file: p:\i\p\in\hmb\org\PM\Great\_Lakes\Documents\Indianapolis Projects\78704 INDOT-S I-64 ATL 00 CAD-ORD\Sheets\Bridges\Bridg No. 10A - I-64 EB over Cherry St\1702614\_S\_TYP01.dgn

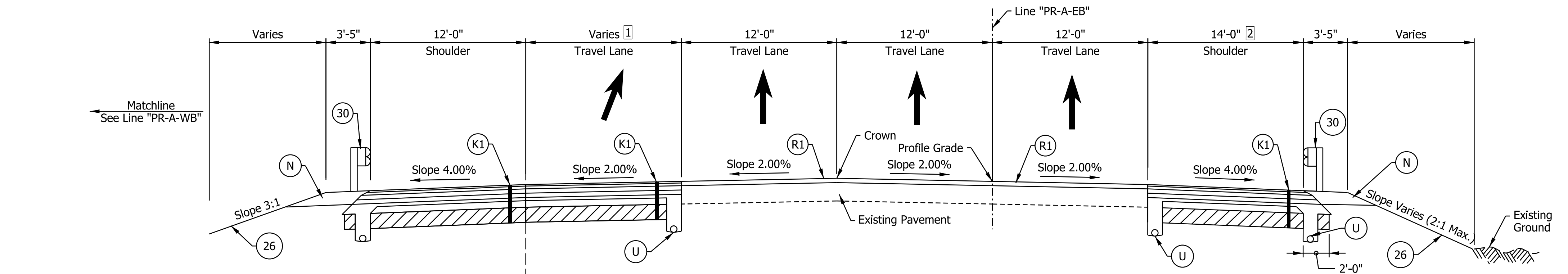

**I-64 EB TYPICAL SECTION**  
 STA. 1328+04.00 "PR-A-EB" TO STA. 1335+38.00 "PR-A-EB"

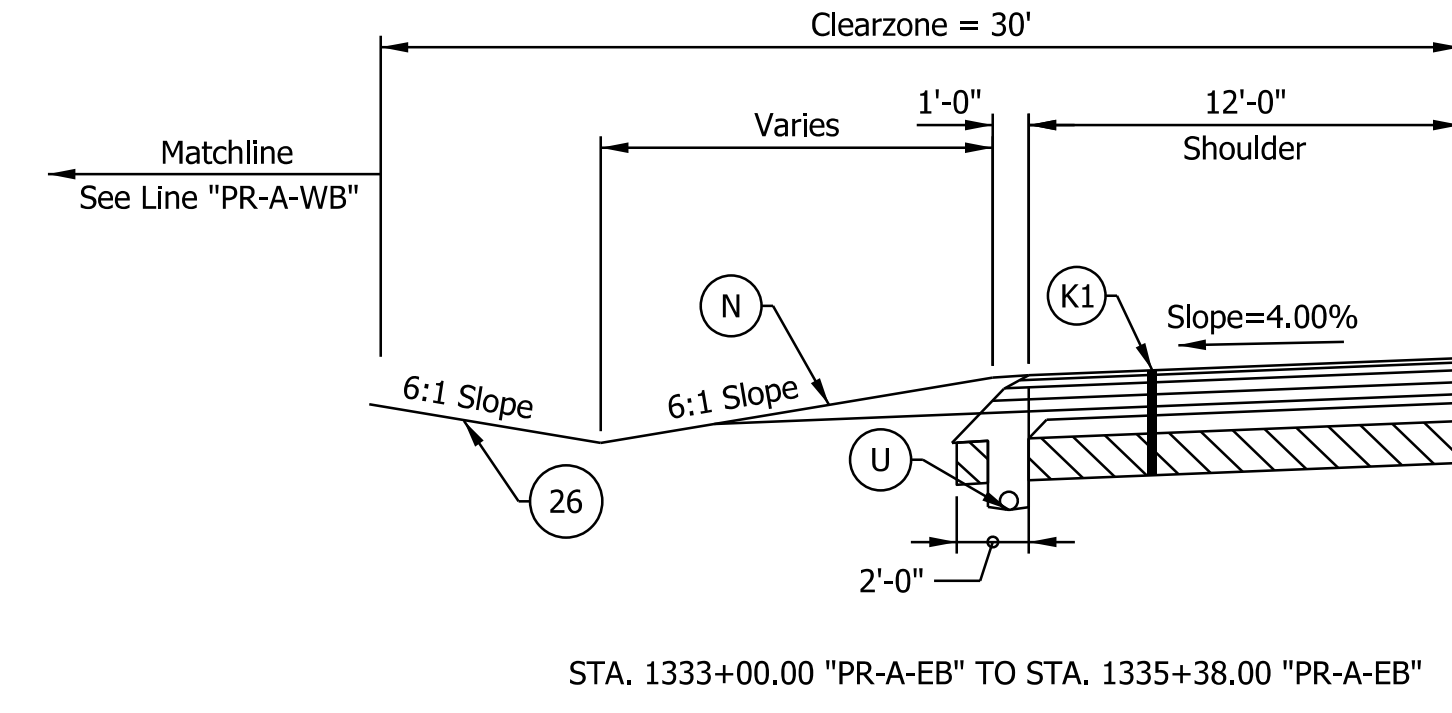

STA. 1333+00.00 "PR-A-EB" TO STA. 1335+38.00 "PR-A-EB"

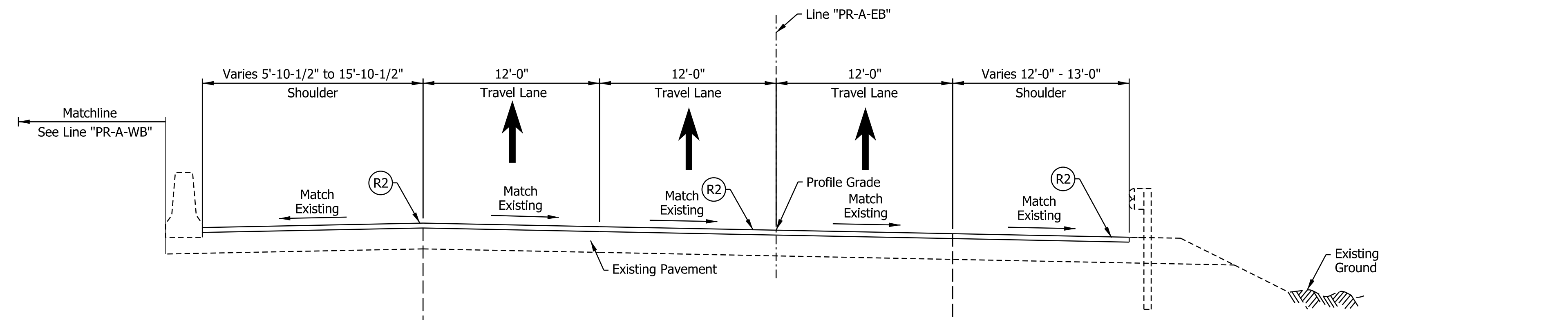

**I-64 EB TYPICAL SECTION**  
 STA. 1335+38.00 "PR-A-EB" TO STA. 1383+96.28 "PR-A-EB"  
 Paving Exception Sta. 1353+05.04 to Sta. 1355+03.52 "PR-A-EB"  
 Paving Exception Sta. 1383+96.28 to Sta. 1386+06.25 "PR-A-EB"

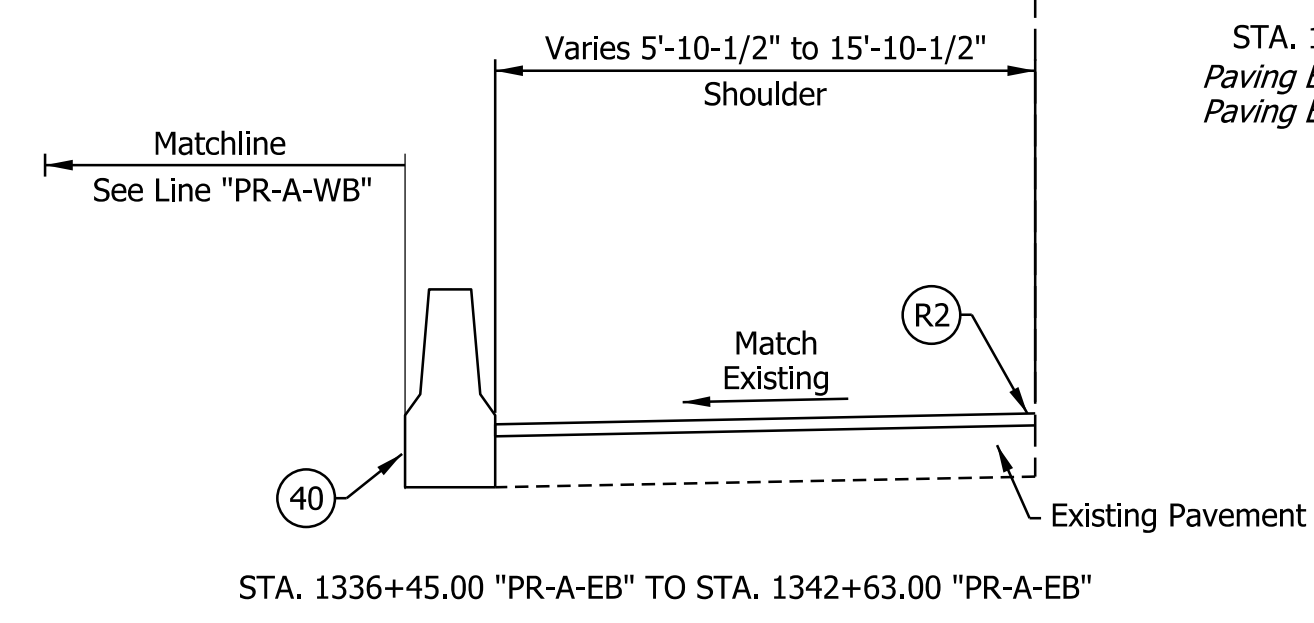

STA. 1336+45.00 "PR-A-EB" TO STA. 1342+63.00 "PR-A-EB"

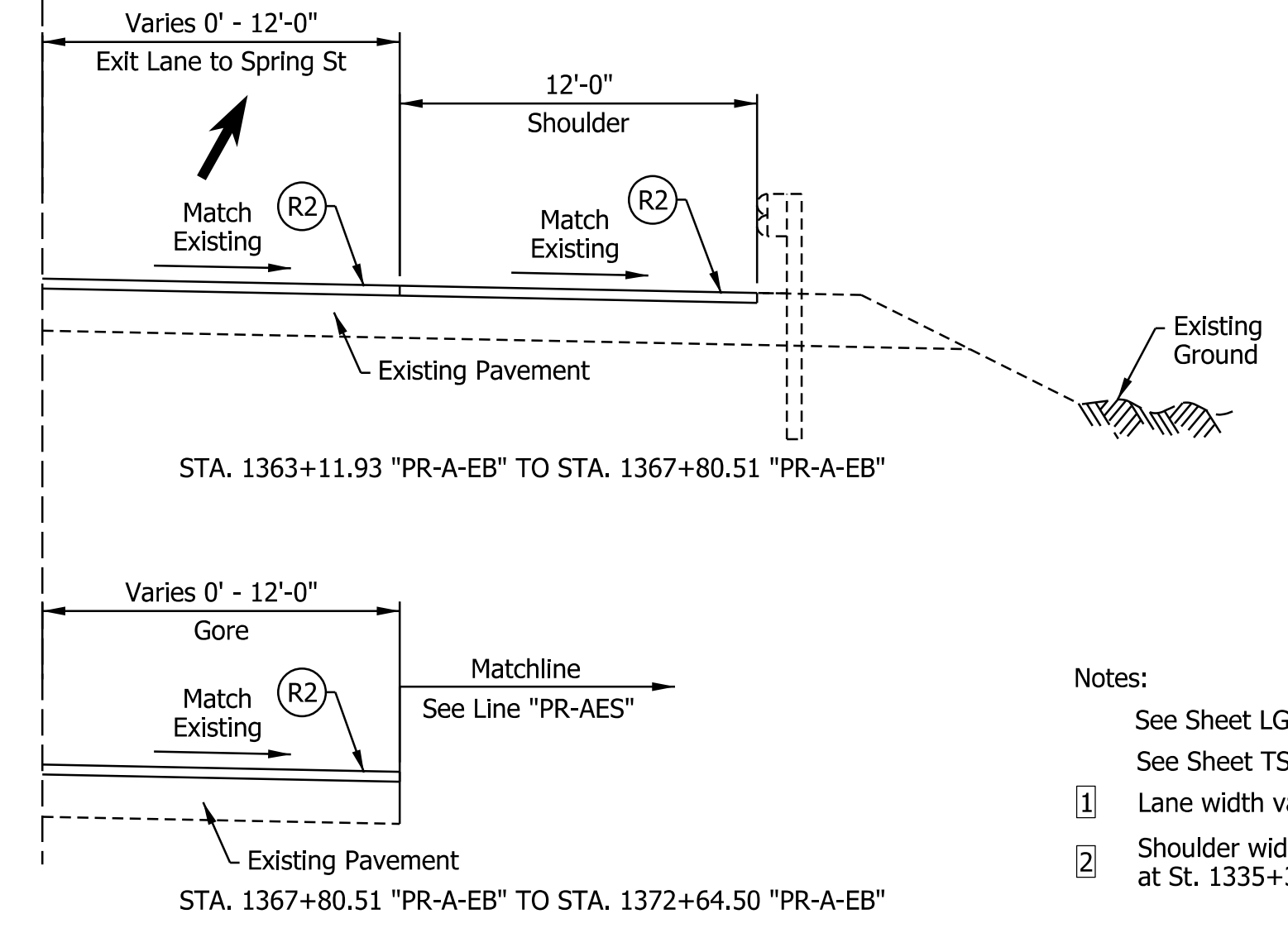

STA. 1363+11.93 "PR-A-EB" TO STA. 1367+80.51 "PR-A-EB"

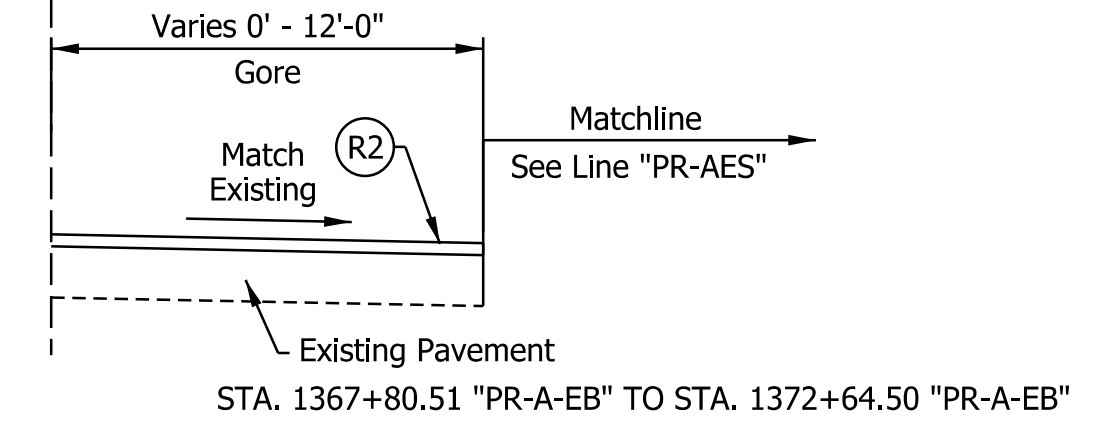

STA. 1367+80.51 "PR-A-EB" TO STA. 1372+64.50 "PR-A-EB"

- Notes:
- See Sheet LGD-01 for construction legend
  - See Sheet TS-43 for Safety Edge Details
  - ① Lane width varies from 12'-0" at Sta. 1323+93.14 to 0'-0" Sta. 1333+00.00
  - ② Shoulder width varies from 14'-0" at Sta. 1333+00.00 to 12'-0" at St. 1335+38.00

FOR INFORMATION ONLY

**DRAFT**  
 NOT FOR CONSTRUCTION

RECOMMENDED FOR APPROVAL _____	DESIGN ENGINEER _____	DATE _____
DESIGNED: _____ SGM _____	DRAWN: _____ CGR _____	
CHECKED: _____ ADR _____	CHECKED: _____ ADR _____	

**INDIANA**  
**DEPARTMENT OF TRANSPORTATION**

**TYPICAL SECTIONS**  
**LINE "PR-A-EB"**

HORIZONTAL SCALE	BRIDGE FILE
AS NOTED	164-122-04988 D
VERTICAL SCALE	DESIGNATION
AS NOTED	1702614
SURVEY BOOK	SHEETS TS-01
ELECTRONIC	3 of 14
CONTRACT	PROJECT
R-42570	1900162

Notes:

- See Sheet LGD-01 for construction legend
- See Sheet TS-43 for Safety Edge Details
- 1 Lane width varies from 12'-0" at Sta. 2334+00.00 to 0'-0" at Sta. 2339+80.00
- 2 Shoulder width varies from 14'-0" at Sta. 2334+00.00 to 10'-10" at Sta. 2339+80.00
- 3 Shoulder width varies, maximum of 19'-6". Match Existing.

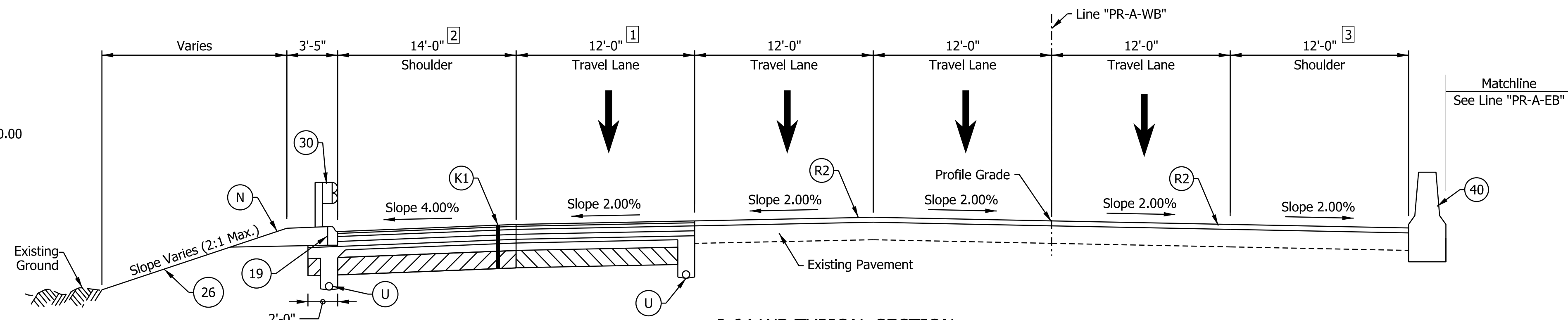

I-64 WB TYPICAL SECTION

STA. 2337+79.00 "PR-A-WB" TO STA. 2339+80.00 "PR-A-WB"

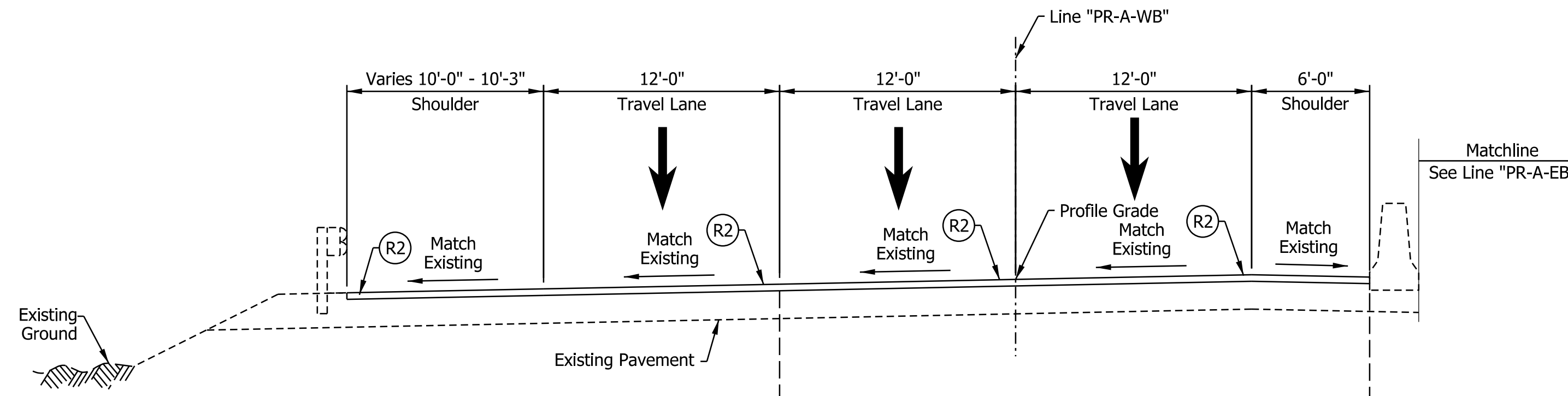

I-64 WB TYPICAL SECTION

STA. 2339+80.00 "PR-A-WB" TO STA. 2385+47.44 "PR-A-WB"  
 Paving Exception Sta. 2354+86.59 to Sta. 2356+85.07 "PR-A-WB"  
 Paving Exception Sta. 2385+47.44 to Sta. 2387+57.40 "PR-A-WB"

STA. 2337+82.00 "PR-A-WB" TO STA. 2344+00.00 "PR-A-WB"

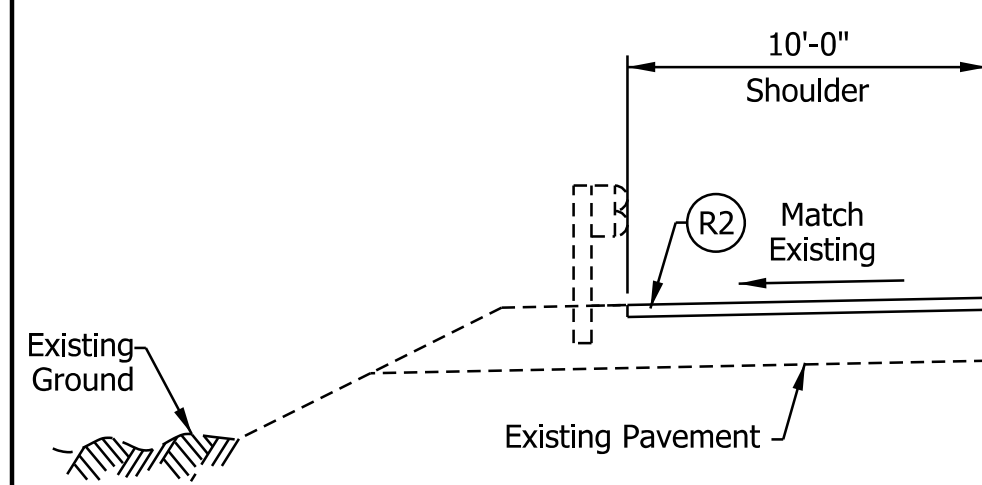

STA. 2375+14.90 "PR-A-WB" TO STA. 2385+35.00 "PR-A-WB"

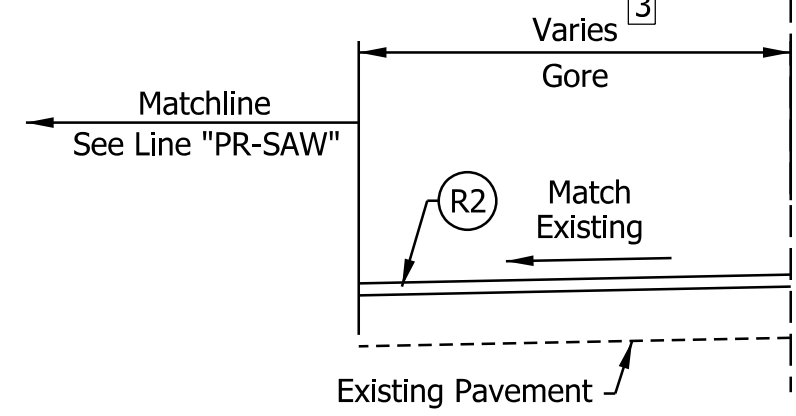

STA. 2372+38.29 "PR-A-WB" TO STA. 2375+14.90 "PR-A-WB"

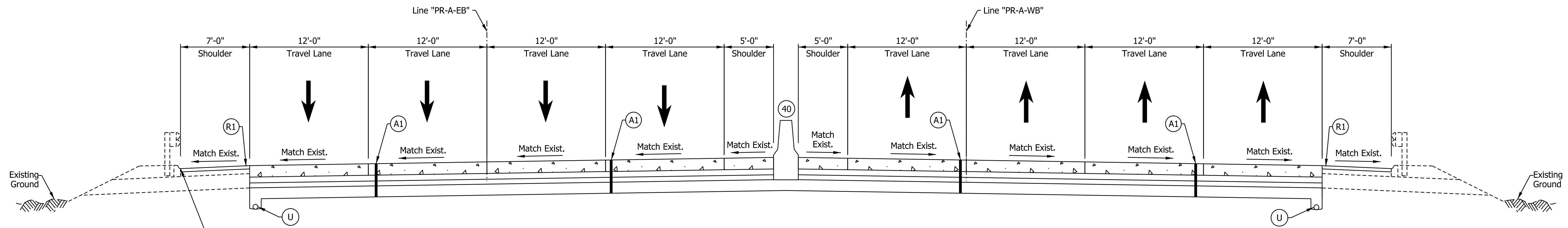

I-64 EB TYPICAL SECTION

STA. 1386+06.25 "PR-A-EB" TO STA. 2388+71.50 "PR-A-EB"

FOR INFORMATION ONLY

I-64 WB TYPICAL SECTION

STA. 2387+57.40 "PR-A-WB" TO STA. 2390+10.10 "PR-A-WB"

**DRAFT**  
NOT FOR CONSTRUCTION

RECOMMENDED FOR APPROVAL _____	DESIGN ENGINEER _____	DATE _____
DESIGNED: _____ SDR _____	DRAWN: _____ CGM _____	
CHECKED: _____ ADR _____	CHECKED: _____ ADR _____	

INDIANA DEPARTMENT OF TRANSPORTATION  
TYPICAL SECTIONS  
LINE "PR-A-WB"

HORIZONTAL SCALE	BRIDGE FILE
AS NOTED	164-122-04988 D
VERTICAL SCALE	DESIGNATION
AS NOTED	1702614
SURVEY BOOK	SHEETS TS-02
ELECTRONIC	4 of 14
CONTRACT	PROJECT
R-42570	1900162

khamison 12/5/2022; 1:11:22 PM model: TYP-01 [Sheet] file: p:\i\p\in\hmb\org\PM\Great\_Lakes\Documents\Indianapolis Projects\78704 INDOT-S I-64 ATL 00 CAD-ORD\Sheets\Bridges\Bridg No. 10A - I-64 EB over Cherry St\1702614\_S\_TYP002.dgn



SEC. 34-T2S-R6E  
NEW ALBANY TOWNSHIP  
FLOYD COUNTY

SEC. 34-T2S-R6E  
NEW ALBANY TOWNSHIP  
FLOYD COUNTY

FOR INFORMATION ONLY

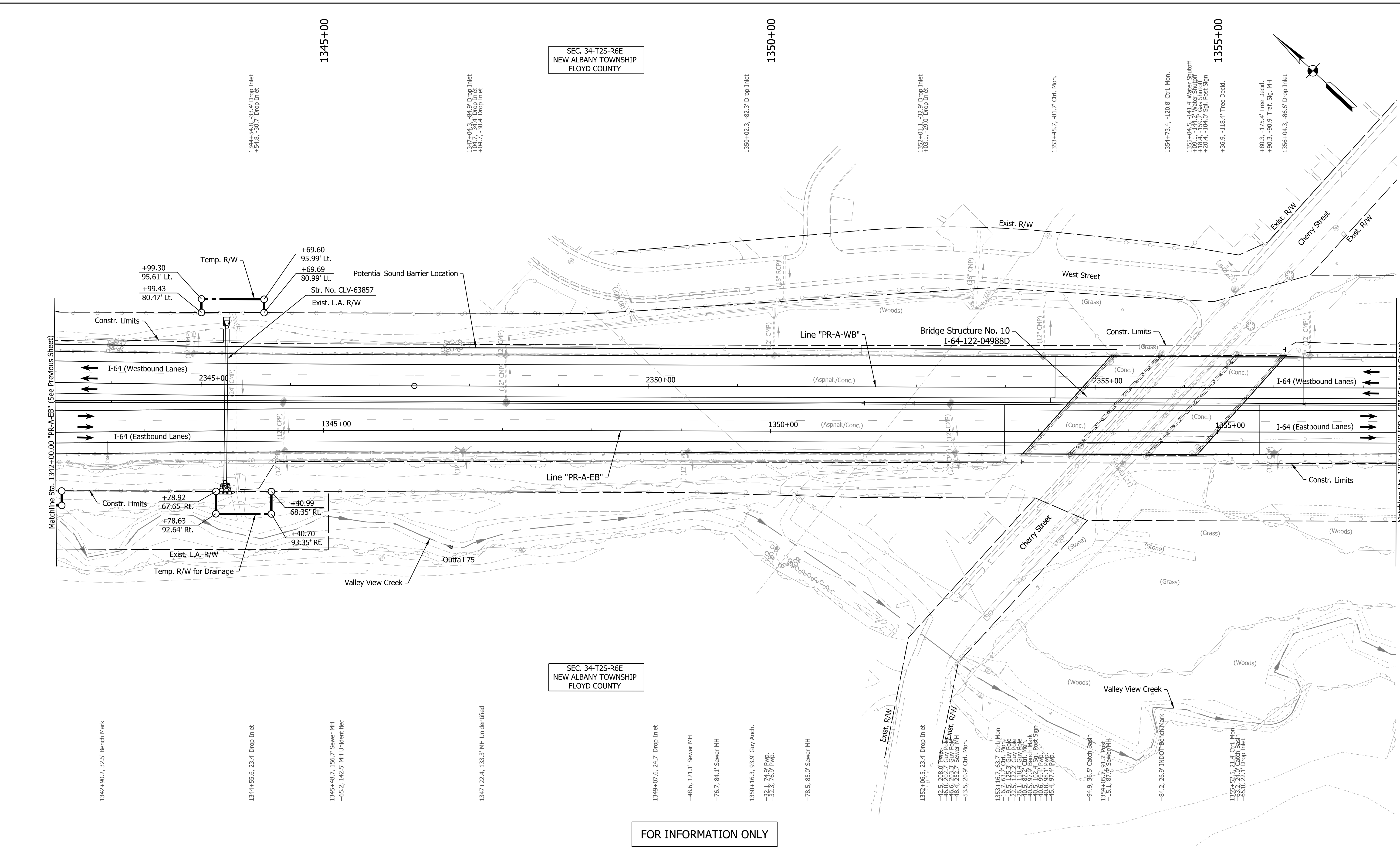

Note:  
For Geometric information see Geometric Layout Sheets  
GEO-01 to GEO-13.

**DRAFT**  
NOT FOR CONSTRUCTION

RECOMMENDED FOR APPROVAL	DESIGN ENGINEER	DATE
DESIGNED: SGM	DRAWN: RJS	
CHECKED: KRC	CHECKED: KRC	

INDIANA  
DEPARTMENT OF TRANSPORTATION

PLAN SHEET  
LINE "PR-A-EB" - STA. 1342+00 TO STA. 1357+00  
LINE "PR-A-WB" - STA. 2342+00 TO STA. 2357+00

HORIZONTAL SCALE	BRIDGE FILE	
AS NOTED	164-122-04988 D	
VERTICAL SCALE	DESIGNATION	
AS NOTED	1702614	
SURVEY BOOK	SHEETS	PP-01
ELECTRONIC	5	of 14
CONTRACT	PROJECT	
R-42570	1900162	

khamison  
12/5/2022; 1:12:07 PM  
model: TYP-01 [Sheet]  
file: p:\i\p\in\hmb\org\PM\Great\_Lakes\Documents\Indianapolis Projects\78704 INDOT-S I-64 ATL\00 CAD-ORD\Sheets\Bridge\No. 104 - I-64 EB over Cherry\Bridge No. 104 - I-64 EB over Cherry\_S1702614\_S\_PP-01.dgn

**GENERAL NOTES**

Reinforcing Steel covering shall be 2 1/2" in top and 1" minimum in the bottom of the floor slab, and 2" in all other parts, unless noted.

All exposed faces of concrete bridge and transition railings to be sealed in accordance with Article 702.21 of the Specifications. (Estimated Quantity = 4,734 Sft.)

Where new work is to be fitted to the old work, the Contractor shall check and verify all dimensions, elevations and conditions in the field and report any errors or discrepancies to the Engineer and assume responsibility for their correctness and the fit of the new construction to the existing structure.

Data shown for existing bridge and subsequent geometry for proposed structure taken from original structure plans.

Original and Rehabilitation Plans for existing structure are on file in the Research and Documents Section at the Indiana Department of Transportation, as Bridge File No. I-64-124-4988, I-64-124-4988A, I-64-124-4988B, I-64-124-4988C and are available upon request.

**DESIGN DATA**

**LIVE LOAD**

Original Structure Designed for HS20-44 and Military Loading with impact and distribution of loads in accordance with 1961 AASHTO Standard Specifications for Highway Bridges. EB Structure widening Designed for HS20-44 and Military Loading with impact and distribution of loads in accordance with 2002 AASHTO Standard Specifications for Highway Bridges.

**DEAD LOAD**

Original Structure and Widened Structure designed for actual weight plus 35 psf for future wearing surface.

**DESIGN STRENGTHS**

To be in accordance with AASHTO LRFD Bridge Design Specifications, Ninth Edition, 2020.

CONCRETE:  
CLASS "C": f<sub>c</sub> = 4,000  
REINFORCING STEEL:  
GRADE 60: f<sub>c</sub> = 60,000 PSI

**MATERIAL NOTES**

1 1/2", 2", or 2 1/2" Latex Modified Concrete, LMC-VE

**NOTES**

- For Typical Bridge Sections, see Dwg. No. PLN-02.
- For clarity, the dimensions shown are based off existing plans while the alignments are based on survey data. Discrepancies may exist between the data.

**LEGEND**

- 2" Bridge Deck Remove Exist. Conc. Overlay; Use Hydrodemolition to remove unsound concrete (Total Bridge Deck Remove Exist. Conc. Overlay = 769 Sys) Construct 2 1/2" Bridge Deck Overlay (LMC-VE) (Total Bridge Deck Overlay LMC-VE = 769 Sys) Perform Longitudinal Grooving on Deck
- 1" Bridge Deck Remove Exist. Conc. Surface; Use Hydrodemolition to remove unsound concrete (Total Bridge Deck Remove Exist. Conc. Surface = 993 Sys) Construct 1 1/2" Bridge Deck Overlay (LMC-VE) (Total Bridge Deck Overlay LMC-VE = 993 Sys) Perform Longitudinal Grooving on Deck
- 1 3/4" Bridge Deck Remove Exist. Conc. Overlay; 1/2" Bridge Deck Remove Exist. Conc. Surface; Use Hydrodemolition to remove unsound concrete (Total Bridge Deck Remove Exist. Conc. Overlay = 1,659 Sys) (Total Bridge Deck Remove Exist. Conc. Surface = 1,659 Sys) Construct 2" Bridge Deck Overlay (LMC-VE) (Total Bridge Deck Overlay LMC-VE = 1,659 Sys) Perform Longitudinal Grooving on Deck
- Type 1-A Construction Joint to be installed on Reinforced Concrete Bridge Approach overlay to perpetuate the existing longitudinal construction joint. (See Unique Special Provision)

**PRESTRESSED CONCRETE I-BEAM BRIDGE**  
**3 SPANS: 52'-11", 86'-11 1/2", 52'-11"**  
**54'-10 1/2" CLEAR ROADWAY (EASTBOUND)**  
**52'-1 1/2" CLEAR ROADWAY (WESTBOUND)**  
**SKEW: 41°55'00" RT.**  
**I-64 EB/WB OVER CHERRY STREET**  
**FLOYD COUNTY**

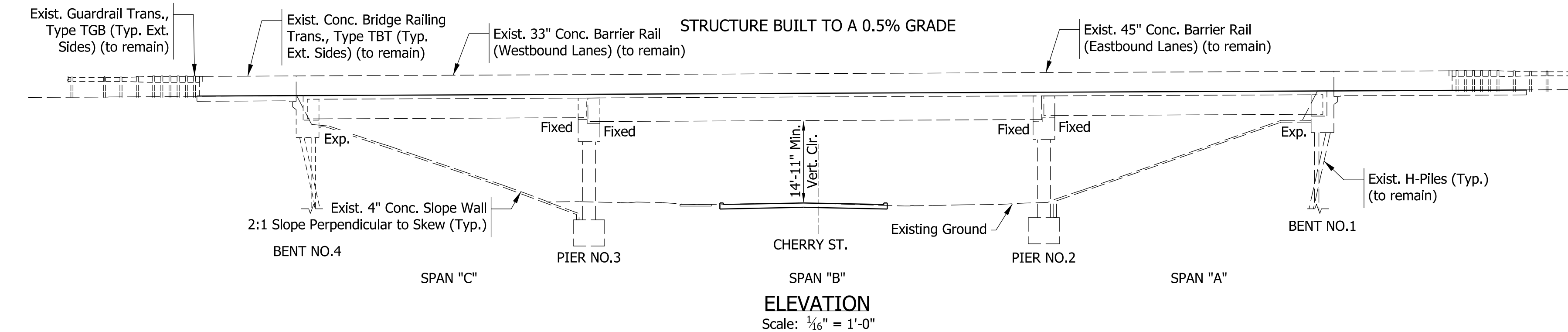

**NOTE TO REVIEWER**  
 The names of the substructure units are from existing plans. The alignment from existing plans ran the opposite direction as the alignments currently shown from survey. This causes the names to be in reverse order compared to normal naming convention.

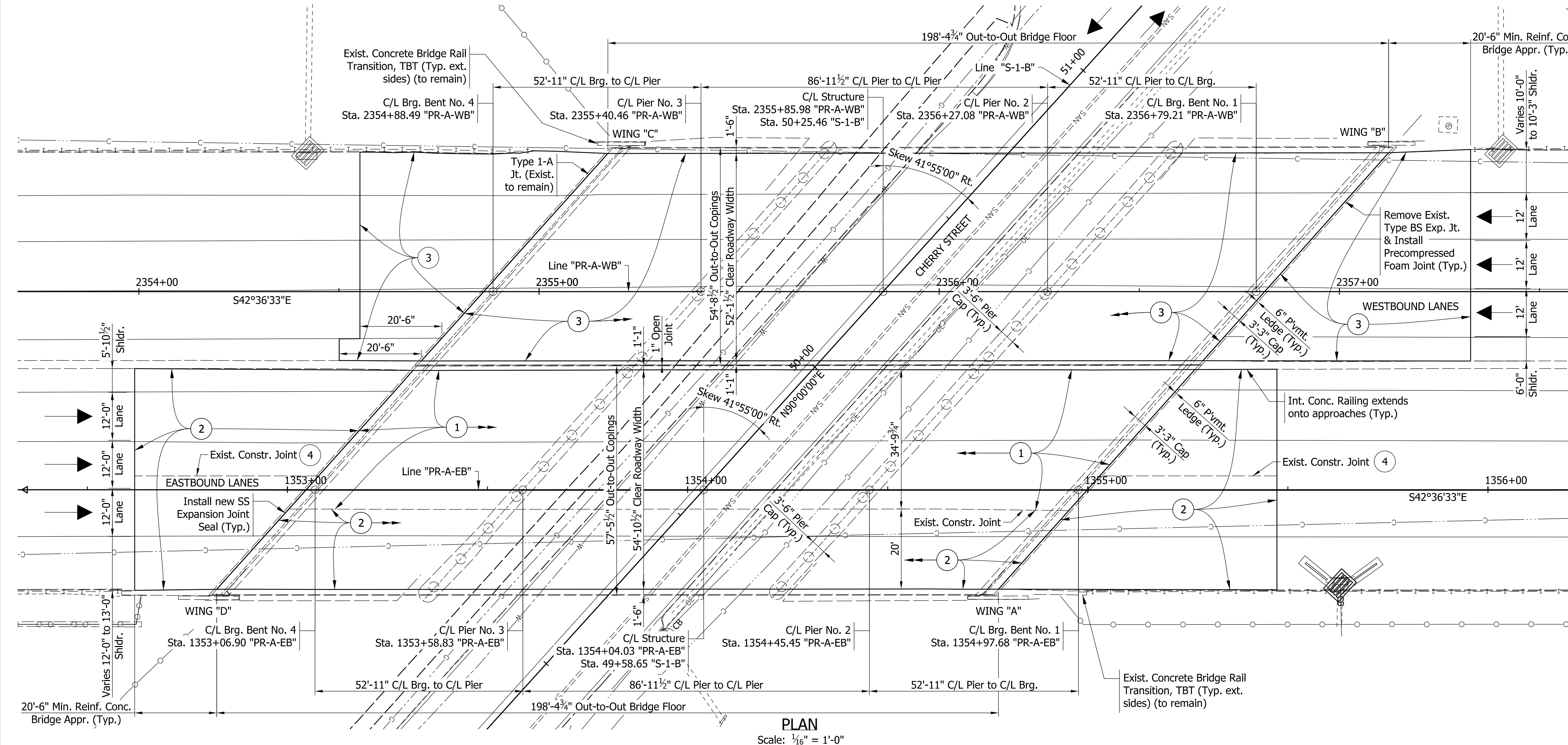

khamison  
 12/5/2022; 1:12:43 PM  
 model: PLN-01 [Sheet]  
 file: p:\i\p\in\lmb\org\PM\Great\_Lakes\Documents\Indianapolis Projects\78704 INDOT-S I-64 ATL100 CAD-ORD\Sheets\Bridges\Bridges No. 104 - I-64 EB over Cherry St\1702614\_S\_PLN01.dgn

**DRAFT**  
 NOT FOR CONSTRUCTION

RECOMMENDED FOR APPROVAL	DESIGN ENGINEER	DATE
DESIGNED: KCH	DRAWN: KCH	
CHECKED: MJF	CHECKED: MJF	

INDIANA DEPARTMENT OF TRANSPORTATION	
GENERAL PLAN	

HORIZONTAL SCALE	BRIDGE FILE
AS NOTED	164-122-04988 D
VERTICAL SCALE	DESIGNATION
AS NOTED	1702614
SURVEY BOOK	SHEETS
ELECTRONIC	8 of 14
CONTRACT	PROJECT
R-42570	1900162

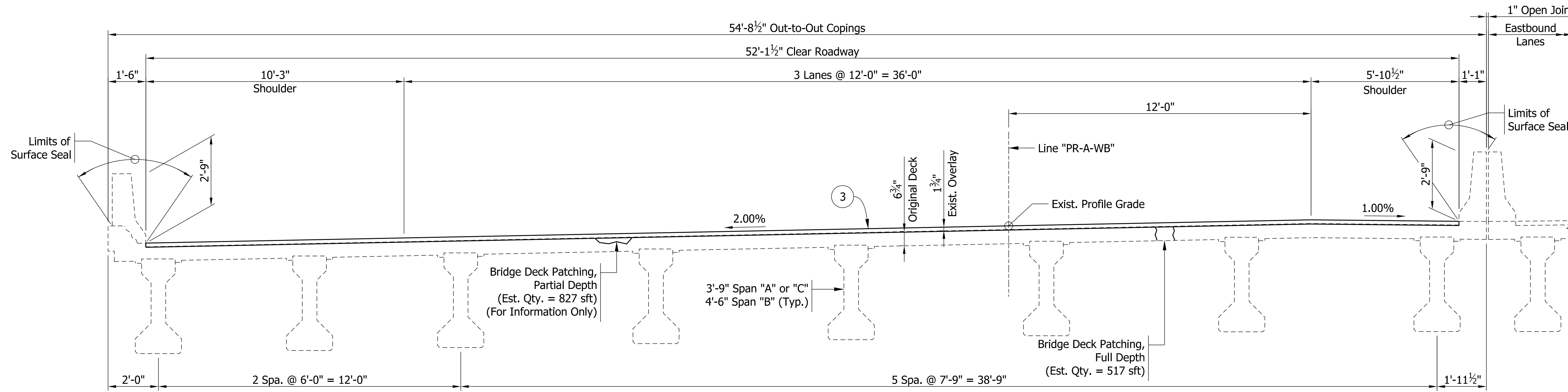

TYPICAL BRIDGE SECTION - WESTBOUND LANES  
Scale: 3/8" = 1'-0"

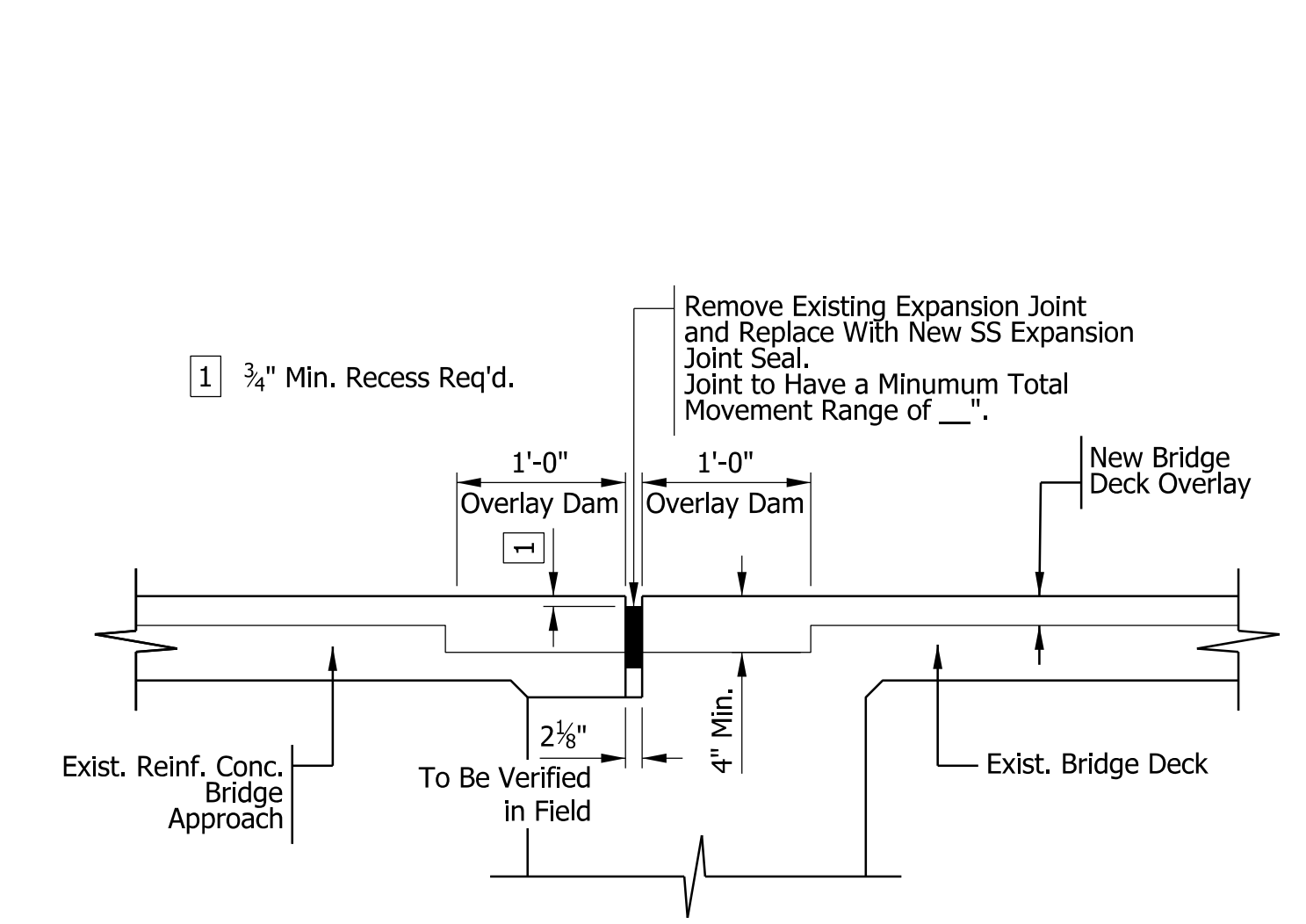

OVERLAY DAM DETAIL  
Scale: 1" = 1'-0"

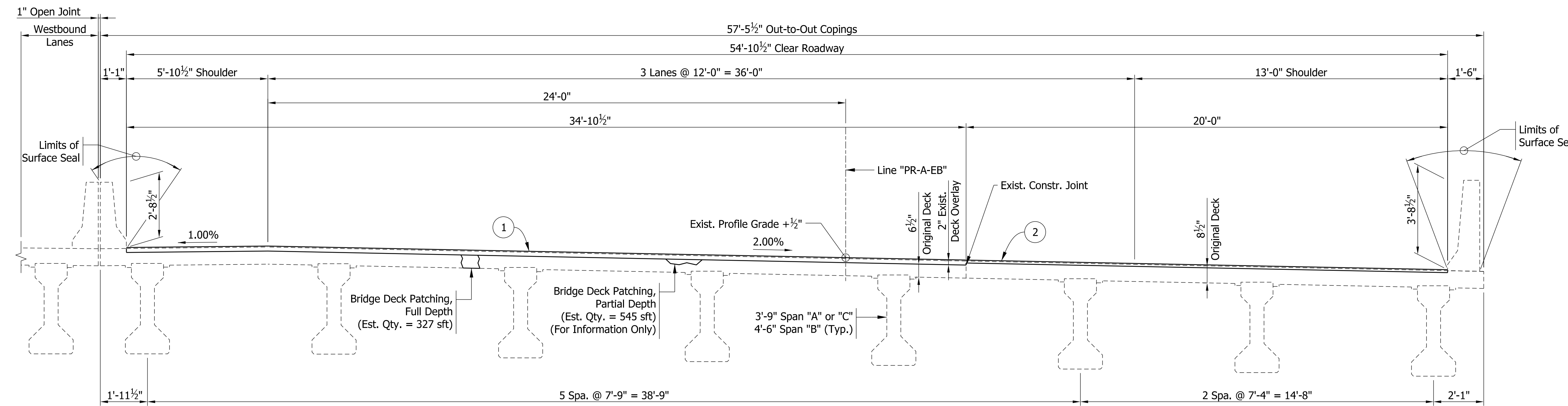

TYPICAL BRIDGE SECTION - EASTBOUND LANES  
Scale: 3/8" = 1'-0"

LEGEND

- 1 2" Bridge Deck Remove Exist. Conc. Overlay; Use Hydrodemolition to remove unsound concrete (Total Bridge Deck Remove Exist. Conc. Overlay = 769 Sys) Construct 2 1/2" Bridge Deck Overlay (LMC-VE) (Total Bridge Deck Overlay LMC-VE = 769 Sys) Perform Longitudinal Grooving on Deck
- 2 1" Bridge Deck Remove Exist. Conc. Surface; Use Hydrodemolition to remove unsound concrete (Total Bridge Deck Remove Exist. Conc. Surface = 993 Sys) Construct 1 1/2" Bridge Deck Overlay (LMC-VE) (Total Bridge Deck Overlay LMC-VE = 993 Sys) Perform Longitudinal Grooving on Deck
- 3 1 3/4" Bridge Deck Remove Exist. Conc. Overlay; 1/4" Bridge Deck Remove Exist. Conc. Surface; Use Hydrodemolition to remove unsound concrete (Total Bridge Deck Remove Exist. Conc. Overlay = 1,659 Sys) (Total Bridge Deck Remove Exist. Conc. Surface = 1,659 Sys) Construct 2" Bridge Deck Overlay (LMC-VE) (Total Bridge Deck Overlay LMC-VE = 1,659 Sys) Perform Longitudinal Grooving on Deck
- 4 Type 1-A Construction Joint to be installed on Reinforced Concrete Bridge Approach overlay to perpetuate the existing longitudinal construction joint. (See Unique Special Provision)

NOTES

1. For Bridge Plan and Elevation, see Dwg. No. PLN-01.

PRESTRESSED CONCRETE I-BEAM BRIDGE  
3 SPANS: 52'-11", 86'-11 1/2", 52'-11"  
54'-10 1/2" CLEAR ROADWAY (EASTBOUND)  
52'-1 1/2" CLEAR ROADWAY (WESTBOUND)  
SKEW: 41°55'00" RT.  
I-64 EB/WB OVER CHERRY STREET  
FLOYD COUNTY

khamison  
12/5/2022; 1:12:44 PM  
model: PLN-02  
file: p:\i\p\in\hmb\org\PM\Great\_Lakes\Documents\Indianapolis Projects\78704 INDOT-S I-64 ATL 00 CAD-ORD\Sheets\Bridge\Bridge No. 10A - I-64 EB over Cherry St\1702614\_S\_PLN01.dgn

**DRAFT**  
NOT FOR CONSTRUCTION

RECOMMENDED FOR APPROVAL	DESIGN ENGINEER	DATE
DESIGNED: KCH	DRAWN: KCH	
CHECKED: MJF	CHECKED: MJF	

INDIANA  
DEPARTMENT OF TRANSPORTATION

GENERAL PLAN

HORIZONTAL SCALE	BRIDGE FILE
AS NOTED	164-122-04988 D
VERTICAL SCALE	DESIGNATION
AS NOTED	1702614
SURVEY BOOK	SHEETS
ELECTRONIC	9 of 14
CONTRACT	PROJECT
R-42570	1900162

PROJECT	DESIGNATION
1900162	2000326 & 2000323
CONTRACT	BRIDGE FILE
R-42570	I265-00-05513 JCEB & DRCE

STRUCTURE INFORMATION				
STRUCTURE	TYPE	SPAN AND SKEW	OVER	STATION
I265-00-05513 JCEB & DRCE	CONTINUOUS COMPOSITE STEEL BEAM BRIDGE	3 SPANS: 44'-0", 71'-6" & 44'-0" SKEW: 11°52'53" RT.	STATE STREET	Q STRUCTURE Sta. 2024+46.87 "PR-L-EB" Sta. 108+12.99 "PR-LEH"

# INDIANA DEPARTMENT OF TRANSPORTATION

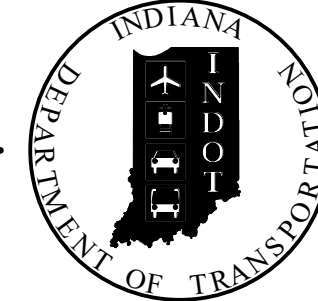

## BRIDGE REHABILITATION PLANS

FOR SPANS OVER 20 FEET

ROUTE: I-265 EB AT: RP 0+97 I-265 EB; RP 0+94 RAMP C

PROJECT NO. 2000326 & 2000323 P.E.

1900162 R/W

2000326 & 2000323 CONST.

DESIGNATION	PROJECT DESCRIPTION	
ROAD		
1900162	I-64 ATL	LEAD DES.
1900366	US 150 and Old Vincennes Road (East)	
2100019	I-64 Lighting US 150 to I-64 / I-265	
BRIDGE		
1800706	Bridge Painting on US 150 EB over I-64, Str.No. 150-22-04983 AEBL	STR. 1
1800405	Bridge Painting on US 150 EB over I-64, Str.No. 150-22-04983 AWBL	STR. 2
1700207	Bridge Replacement on I-64 EB over Quarry Road, Str.No. 164-120-10786	STR. 3
2200015	Bridge Replacement on I-64 WB over Quarry Road, Str.No. 164-120-10742	STR. 4
1702617	Bridge Replacement on I-64 WB over I-64 EB to I-265 EB Ramp, Str.No. 164-121-10787	STR. 5A
2200016	New Bridge on I-64 EB over I-64 EB Ramp to I-265 EB, Str.No.164-121-10743 EBL	STR. 5B
1800721	Bridge Replacement on I-64 WB over I-265 WB Ramp to I-64 EB, Str.No.164-121-10788	STR. 6
2200019	Bridge Replacement on I-265 WB to I-64 EB Ramp over I-64 EB to I-265 EB Ramp, Str.No.(164)I265-00-10746	STR. 7
2200017	Bridge Replacement on I-64 EB over Captain Frank Road, Str.No.164-121-10744	STR. 8
2200018	Superstructure Replacement on I-64 WB over Captain Frank Road, Str. No. 164-121-04986 DWBL	STR. 9
1702614	Bridge Deck Overlay on I-64 over Cherry Street, Str.No. 164-122-04988 D	STR. 10
2000326 / 2000323	Bridge Deck Replacement & Widening on I-265 EB & Ramp Over State Street, Str.No. I265-00-05513 JCEB & DRCE	STR. 11
2000324	Bridge Deck Overlay on I-265 WB Over State Street, Str.No. I265-00-05513 DWBL	STR. 12
1700206	Bridge Deck Replacement I-64 EB over SR 62/ SR 64	STR. 13
1700205	Bridge Deck Replacement on I-64 WB over SR 62/ SR 64	STR. 14
2000144	Bridge Deck Overlay on I-64 EB over Yelowine Lane	STR. 15
2000145	Bridge Deck Overlay on I-64 WB over Yelowine Lane	STR. 16
2002072	US 150 EB over Little Indian Creek, Str.No.150-22-05230 CEB	STR. 18
2002073	US 150 WB over Little Indian Creek, Str.No.150-22-05230 CWB	STR. 19
2200719	I-64 EB & WB over SR 62 / Spring Street, Str.No.164-123-04689 C	STR. 20
2200718	I-64 WB Off-Ramp to Spring Street over I-64 WB On-Ramp from Spring Street, Str.No.164-123-04688 D	STR. 21
DRAINAGE		
TBD	US 150 Twin Arch Pipe Liner	STR. 17
TBD	Valley View Creek (6 Small Structures and 7 Small Pipe Replacements)	
TBD	Valley View Creek CMP Liner	
TBD	UNT to Little Indian Creek CMP Liner	
TBD	Hill Brook CMP Liner	
TBD	Small Pipes CMP Liners (2)	

TRAFFIC DATA	I-265	I-265 EB to STATE STREET RAMP	STATE STREET
A.A.D.T. (2019)	63,860 V.P.D.	6,660 V.P.D.	27,200 V.P.D.
A.A.D.T. (2046)	82,080 V.P.D.	7,680 V.P.D.	34,300 V.P.D.
D.H.V. (2046)	7,180 V.P.H.	630 V.P.H.	2,980 V.P.H.
DIRECTIONAL DISTRIBUTION	53 %	100 %	55 %
TRUCKS	8 % A.A.D.T.	2 % A.A.D.T.	2 % A.A.D.T.
	6 % D.H.V.	3 % D.H.V.	2 % D.H.V.

DESIGN DATA			
DESIGN SPEED	65 M.P.H.	SIGNED AT 25 M.P.H.	
PROJECT DESIGN CRITERIA	RECONSTRUCTION FREEWAY	RECONSTRUCTION FREEWAY	NO IMPROVEMENT
FUNCTIONAL CLASSIFICATION	INTERSTATE	RAMP	
RURAL/URBAN	URBAN	URBAN	
TERRAIN	ROLLING	ROLLING	
ACCESS CONTROL	FULL	FULL	

Bridge Deck Replacement & Widening on I-265 EB & I-265 Ramp over State Street Located 0.84 Miles East of I-64 in Sections 27 & 28, T-2-S, R-6-E, New Albany Township, Floyd County, Indiana

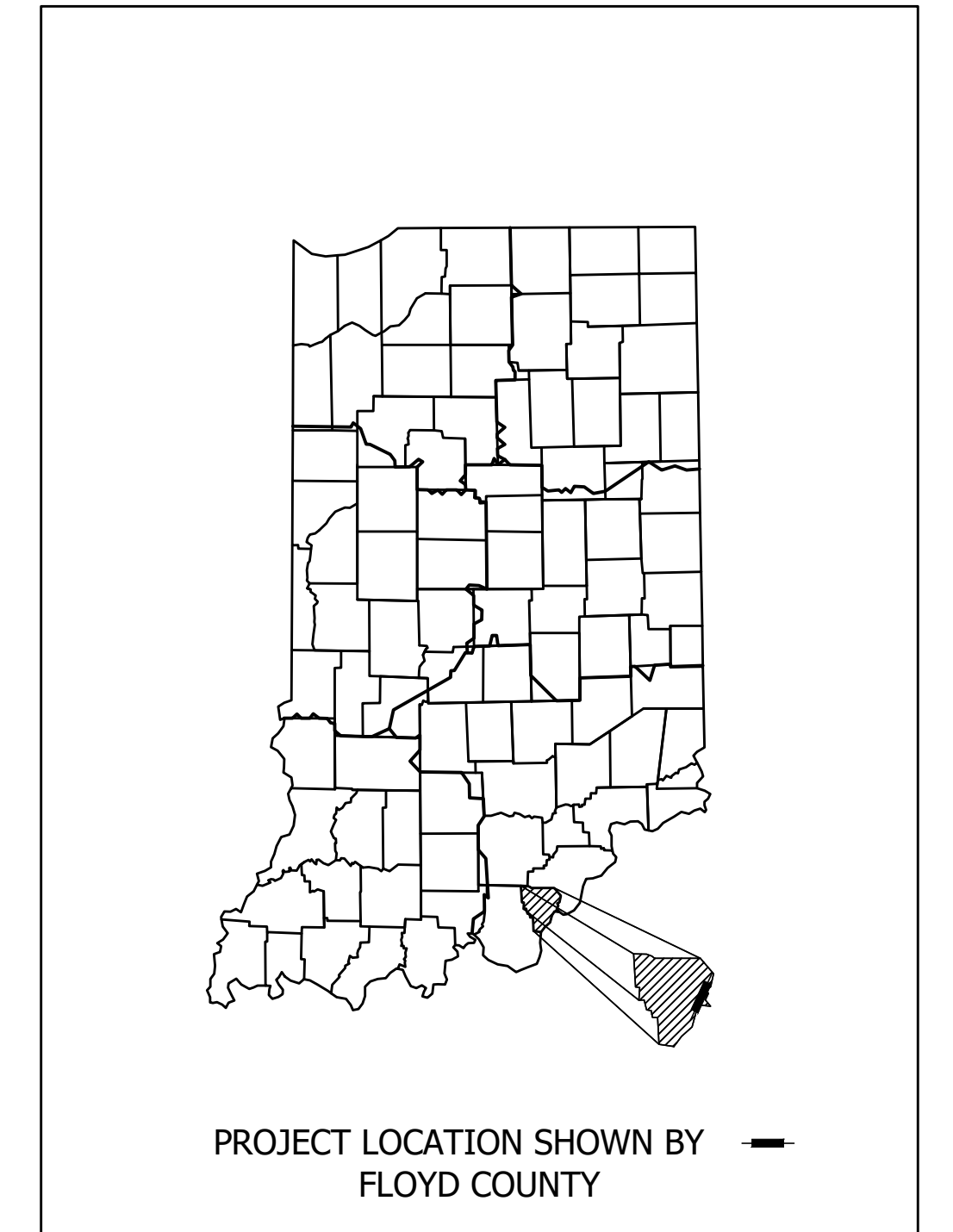
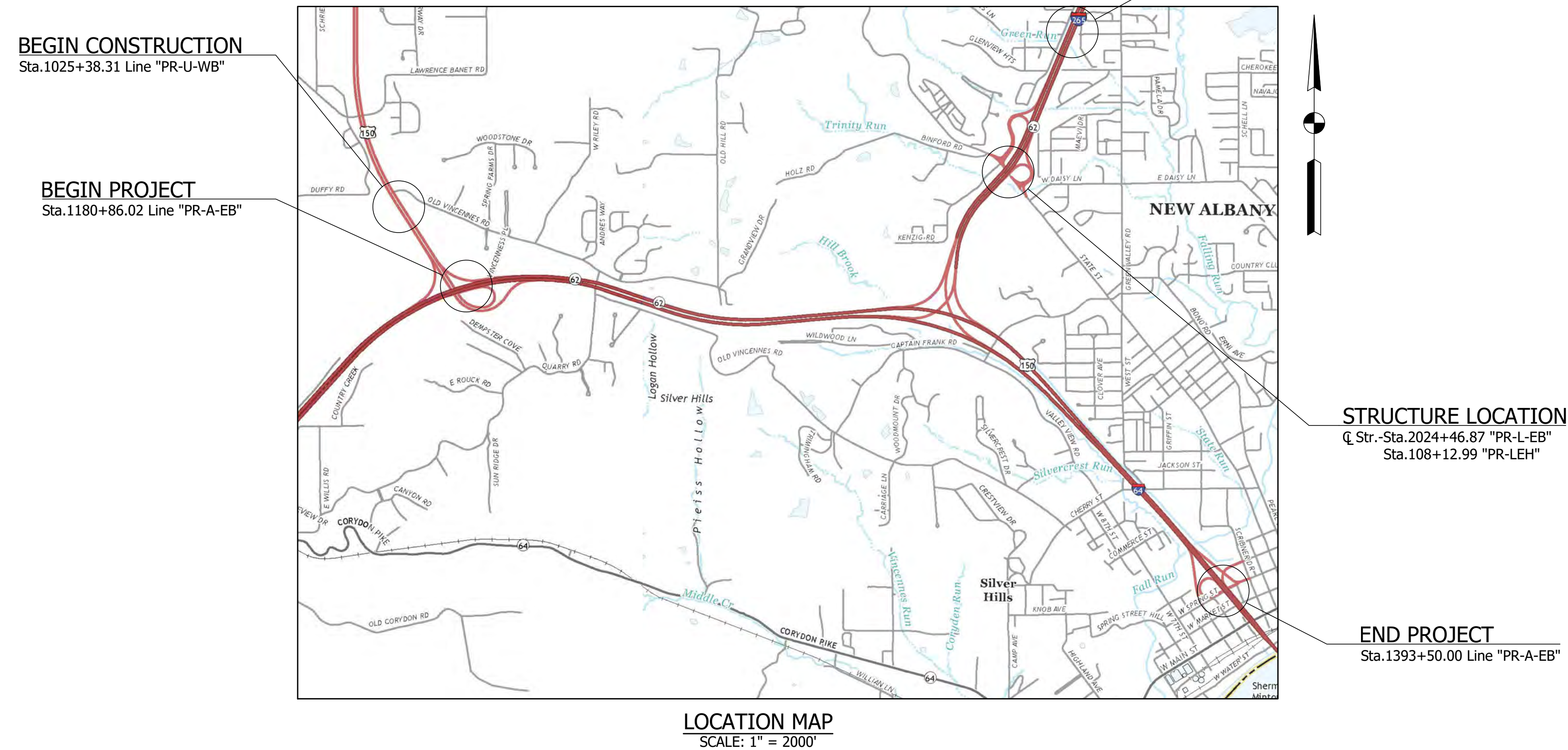

LATITUDE: 38°18'38.8" N LONGITUDE: 85°50'44.3" W

BRIDGE LENGTH: 0.031 MI.  
ROADWAY LENGTH: \* MI.  
TOTAL LENGTH: \* MI.  
MAX. GRADE: -3.31 %

\* SEE DES. NO. 1900162

HUC 12: 051401010904  
HUC 14: 05140101150020

**Note to Reviewer:**  
The list of Kinned Projects is tentative and subject to change at INDOT Seymour District's direction. This list represents the current understanding of the Contract Package

### STAGE 2 PLANS

PLANS PREPARED BY:

8320 CRAIG STREET | INDIANAPOLIS, IN 46250  
317.849.5832 | F. 317.841.4280 | WWW.B-L-N.COM

**DRAFT**  
NOT FOR CONSTRUCTION

PLANS PREPARED BY:	BEAM, LONGEST & NEFF, LLC	(317)849-5832 PHONE NUMBER
CERTIFIED BY:		DATE
APPROVED FOR LETTING:	INDIANA DEPARTMENT OF TRANSPORTATION	DATE

BRIDGE FILE	
I265-00-05513 JCEB & DRCE	
DESIGNATION	
2000326 & 2000323	
DRAWING NO.	SHEETS
	1 of 18
CONTRACT	PROJECT
R-42570	1900162

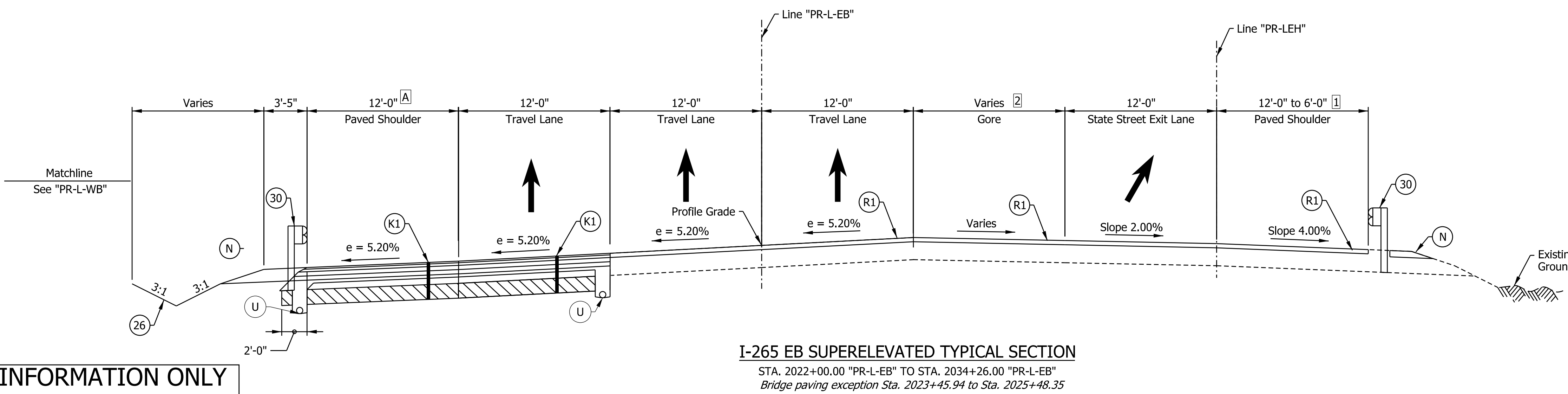
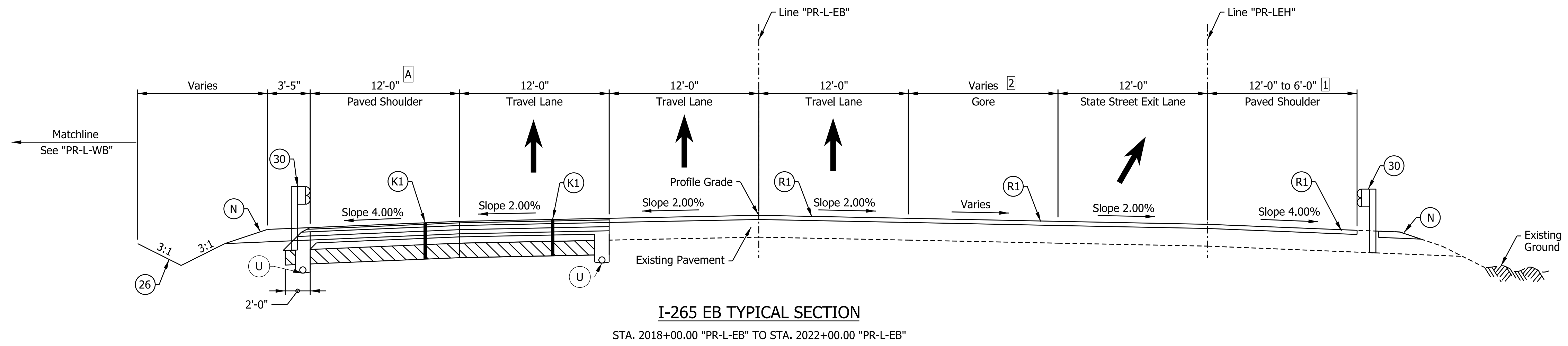
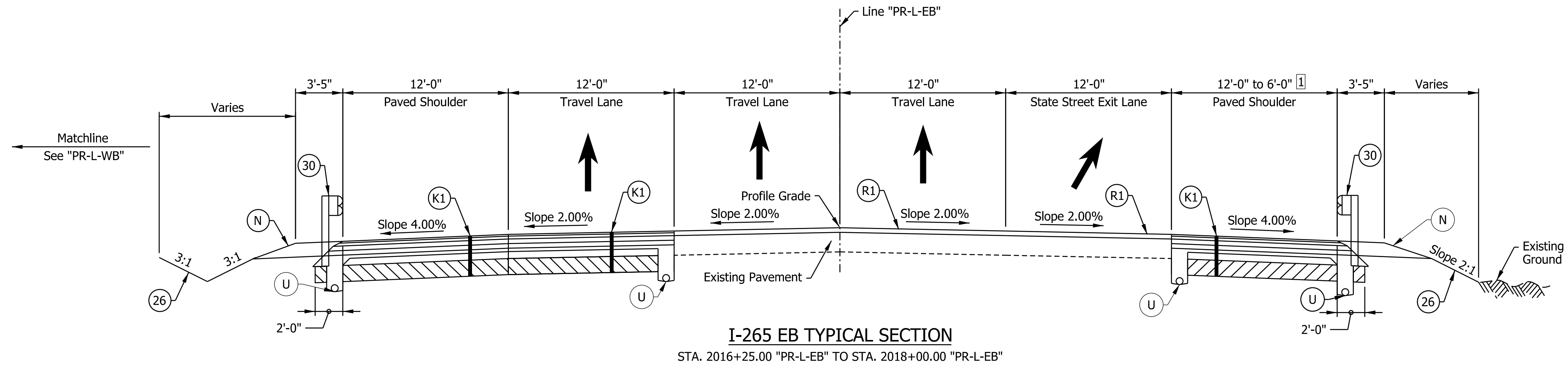

- Notes:
- See Sheet LGD-01 for construction legend
  - See Sheet TS-43 for Safety Edge Details
  - A** Shoulder width shall increase to 12'-0" approaching and exiting the bridge over State Street
  - 1** Shoulder width varies from 12'-0" at Sta. 2015+88 to 6'-0" at Sta. 2023+88
  - 2** Gore width varies from 0'-0" at Sta. 2018+00 to 12'-0" at Sta. 2023+88

**FOR INFORMATION ONLY**

**NOTE TO REVIEWER**  
 Underdrain pipe locations and details to be provided in a future submittal

**DRAFT**  
 NOT FOR CONSTRUCTION

RECOMMENDED FOR APPROVAL _____	DESIGN ENGINEER _____	DATE _____
DESIGNED: _____ DFK _____	DRAWN: _____ DTC _____	
CHECKED: _____ ADR _____	CHECKED: _____ ADR _____	

INDIANA DEPARTMENT OF TRANSPORTATION  
**I-265 EASTBOUND MAINLINE PROPOSED TYPICAL SECTIONS**

HORIZONTAL SCALE	BRIDGE FILE
3/16"=1'-0"	N/A
VERTICAL SCALE	DESIGNATION
N/A	1900162
SURVEY BOOK	SHEETS TS-19
ELECTRONIC	3 of 18
CONTRACT	PROJECT
R-42570	1900162

rstriegel 12/15/2022 7:00:51 PM  
 model: TYP-02 [Sheet]  
 file: p:\i-265\i-265\Documents\Indianapolis Projects\78704 INDOT-S I-64 ATL 00 CAD-ORD\Sheets\Roadway\1900162\_L\_S\_TYP04.dgn









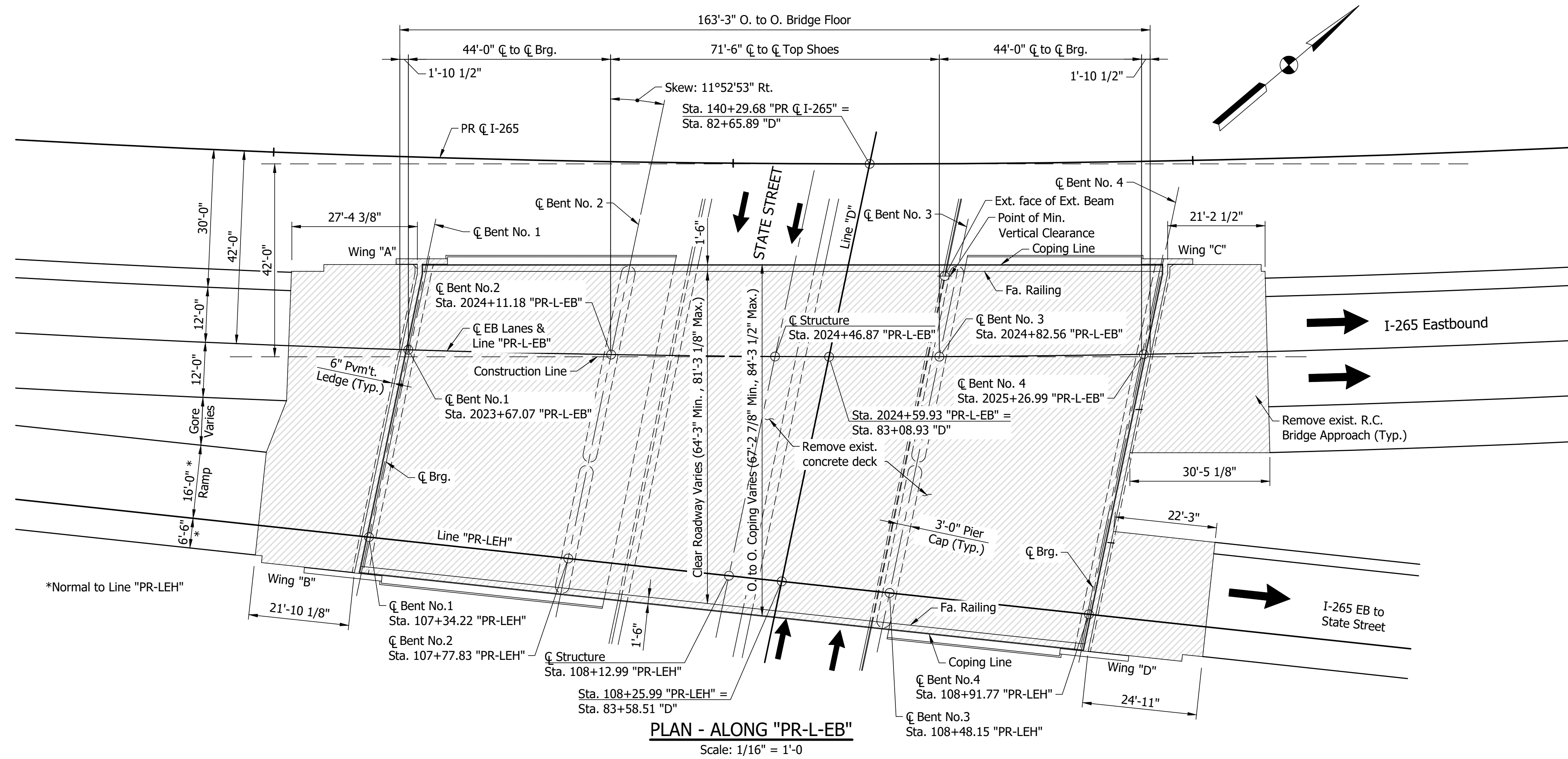
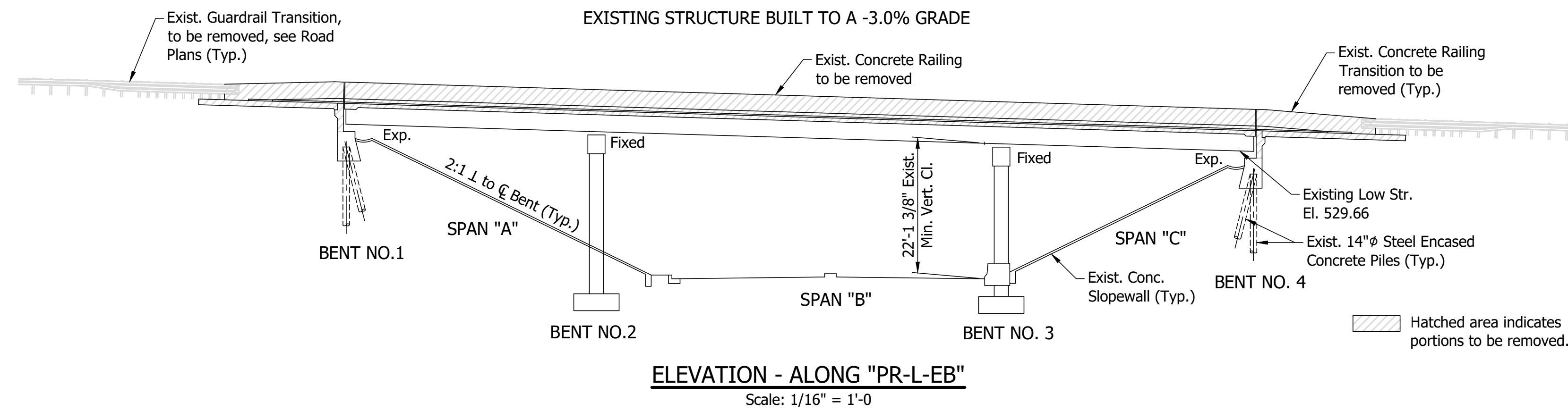

Notes:  
For Proposed Plan and Elevation, see Dwg. S3.  
For Typical Section & General Notes, see Dwg. S4.  
Hatched areas indicate portions to be removed.

CONTINUOUS COMPOSITE STEEL BEAM BRIDGE  
3 SPANS: 44'-0", 71'-6", & 44'-0"  
CLEAR ROADWAY VARIES (64'-3" MIN.) SKEW: 11°52'53" RT.  
I-265 EB AND I-265 RAMP OVER STATE STREET  
FLOYD COUNTY

**DRAFT**  
NOT FOR CONSTRUCTION

RECOMMENDED FOR APPROVAL	DESIGN ENGINEER	DATE
DESIGNED: SJM	DRAWN: JF	
CHECKED: TSW	CHECKED: SJM	

INDIANA  
DEPARTMENT OF TRANSPORTATION

GENERAL PLAN  
EXISTING

HORIZONTAL SCALE	BRIDGE FILE
AS NOTED	1265-00-05513 JCEB & DRCE
VERTICAL SCALE	DESIGNATION
AS NOTED	2000326 & 2000323
DRAWING NO.	SHEETS
S2 of S6	11 of 18
CONTRACT	PROJECT
R-42570	1900162

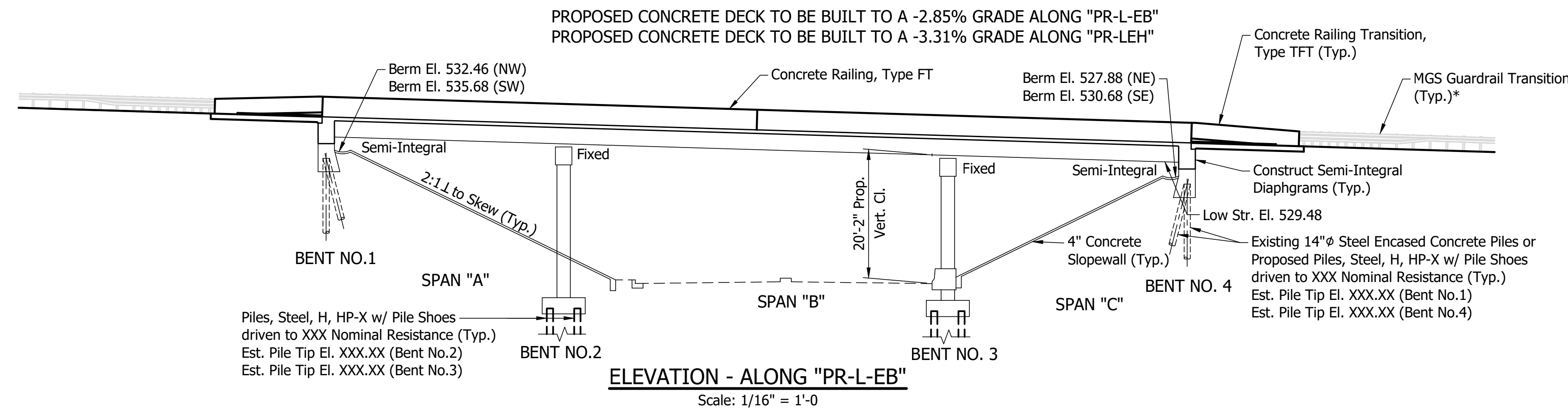

**Note to Reviewer:**  
- The Geotechnical Investigation is currently underway. Soil borings, Pile Size and Type will be added at a future submittal.

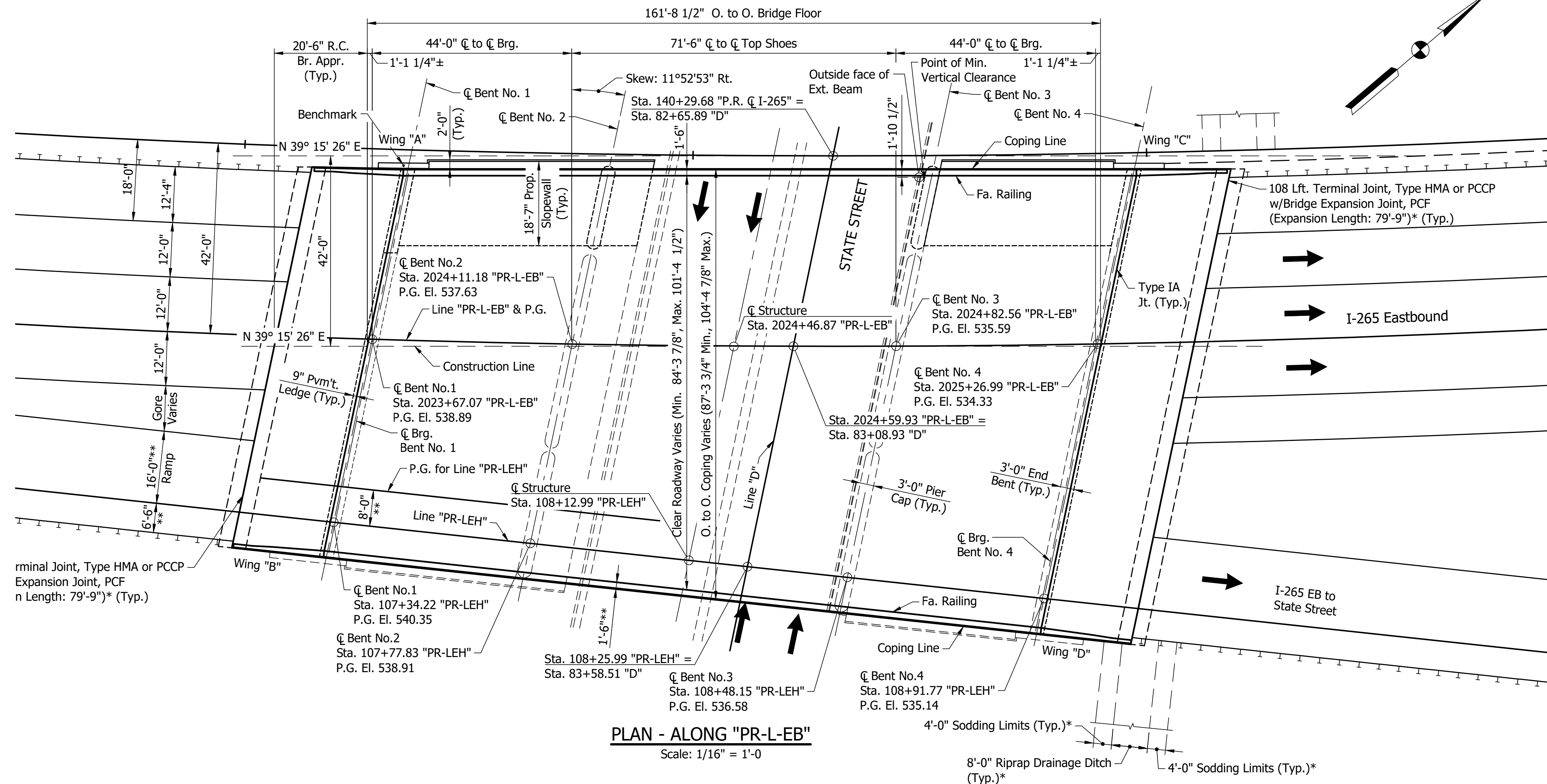

\* Roadway Item  
\*\* Normal to Line "PR-LEH"

Notes:  
For Type IA Joint, see Std.Dwg.No.E609-BRJT-01.  
For Existing Plan and Elevation, see Dwg. S2.  
For Typical Section & General Notes, see Dwg. S4.  
For Stakeout Diagram, see Dwg. S6.

**CONTINUOUS COMPOSITE STEEL BEAM BRIDGE**  
3 SPANS: 44'-0", 71'-6", & 44'-0"  
CLEAR ROADWAY VARIES (84'-3 7/8" MIN.) SKEW: 11°52'53" RT.  
I-265 EB AND I-265 RAMP OVER STATE STREET  
FLOYD COUNTY

**DRAFT**  
NOT FOR CONSTRUCTION

RECOMMENDED FOR APPROVAL	DESIGN ENGINEER	DATE
DESIGNED: SJM	DRAWN: JF	
CHECKED: TSW	CHECKED: SJM	

INDIANA  
DEPARTMENT OF TRANSPORTATION

**GENERAL PLAN  
PROPOSED**

HORIZONTAL SCALE	BRIDGE FILE
AS NOTED	1265-00-05513 JCEB & DRCB
VERTICAL SCALE	DESIGNATION
AS NOTED	2000326 & 2000323
DRAWING NO.	SHEETS
S3 of S6	12 of 18
CONTRACT	PROJECT
R-42570	1900162

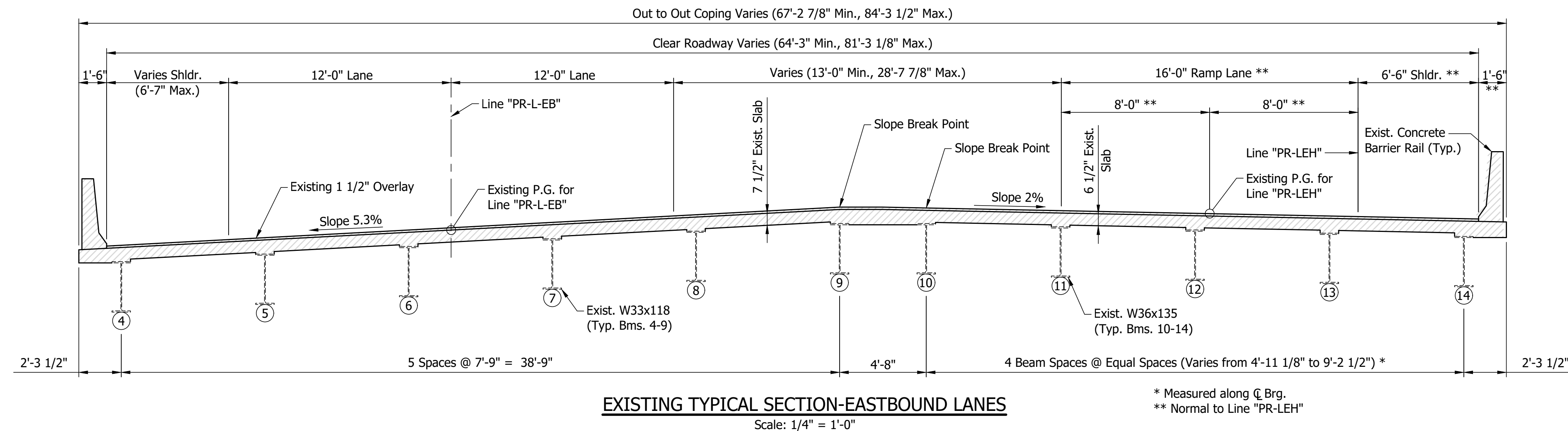

**EXISTING TYPICAL SECTION-EASTBOUND LANES**  
Scale: 1/4" = 1'-0"

\* Measured along C Brg.  
\*\* Normal to Line "PR-LEH"

**DESIGN DATA**

**LIVE LOAD**  
Original Structure designed for HS20-44 loading in accordance with the 1969 AASHTO Specifications. In addition, the widened structure designed for HS20-44 loading in accordance with the 1977 AASHTO Specifications and all interim specifications.

Deck and proposed steel beams designed for HL-93 loading in accordance with the AASHTO LRFD Bridge Design Specifications, Ninth Edition, 2020.

Existing steel beams checked for HS20-44 loading with impact and distribution of loads, in accordance with 2002 AASHTO Standard Specifications.

**DEAD LOAD**  
Actual weight plus 35 psf (composite) for future wearing surface and 15 psf (Non-Composite) for permanent metal deck forms.

**FLOOR SLAB**  
Designed with 7 1/2" structural depth plus 1/2" sacrificial wearing surface

**DESIGN STRENGTHS**

- CONCRETE:**  
Class "A":  $f_c=3,500$  psi  
Class "B":  $f_c=3,000$  psi  
Class "C":  $f_c=4,000$  psi
- REINFORCING BARS:**  
Grade 60:  $F_y=60,000$  psi
- STRUCTURAL STEEL:**  
ASTM A709 Grade 50  $F_y=50$  ksi

**CONSTRUCTION LOADING**

The exterior beams have been checked for strength, deflection, and overturning using the construction loads shown below. Cantilever overhang brackets were assumed for support of the deck overhang past the edge of exterior beam. The finishing machine was assumed to be supported 6 inches outside the vertical coping form. The top overhang brackets were assumed to be located 6 inches past the edge of the vertical coping form. The bottom overhang brackets were assumed to be braced against the intersection of the beam bottom flange and web. The Contractor shall use blocking or other methods to ensure beam rotation does not occur prior to or during concrete placement on exterior beams where diaphragm spacing exceeds 20 ft. See Special Provisions and Dwg xx for additional notes on deck pours.

**DECK FALSEWORK LOADS:**  
Designed for 15 psf for permanent metal stay-in-place deck forms, removable deck forms, and 2-ft. exterior walkway.

**CONSTRUCTION LIVE LOAD:**  
Designed for 20 psf extending 2 ft. past the edge of coping and 75 plf vertical force applied at a distance of 6 inches outside the face of coping over a 30-ft. length of the deck centered with the finishing machine.

**FINISHING-MACHINE LOAD:**  
4,500 lbs distributed over 10 ft. along the coping.

**WIND LOAD:**  
Designed for 70 mph horizontal wind loading in according with AASHTO LRFD 3.8.1.

**SEISMIC DATA**

AASHTO Guide Design Specifications for LRFD Seismic Bridge Design  
Seismic Zone Category X  
S1 = X  
Site Class X  
Fv = X

Notes:  
Hatched area indicates portions to be removed.  
For Existing Plan & Elevation, see Dwg. S2.  
For Proposed Plan & Elevation, see Dwg. S3.  
For Type "A" Construction Joint, see Std.Dwg.No.E702-CJTA-01.  
\* Measured along C Brg.  
\*\* Normal to Line "PR-LEH"  
\*\*\* Slope varies between Beams 9 and 10  
⊗ Denotes Beam Number

**CONTINUOUS COMPOSITE STEEL BEAM BRIDGE**  
3 SPANS: 44'-0", 71'-6", & 44'-0"  
CLEAR ROADWAY VARIES (84'-3 7/8" MIN.) SKEW: 11°52'53" RT.  
I-265 EB AND I-265 RAMP OVER STATE STREET  
FLOYD COUNTY

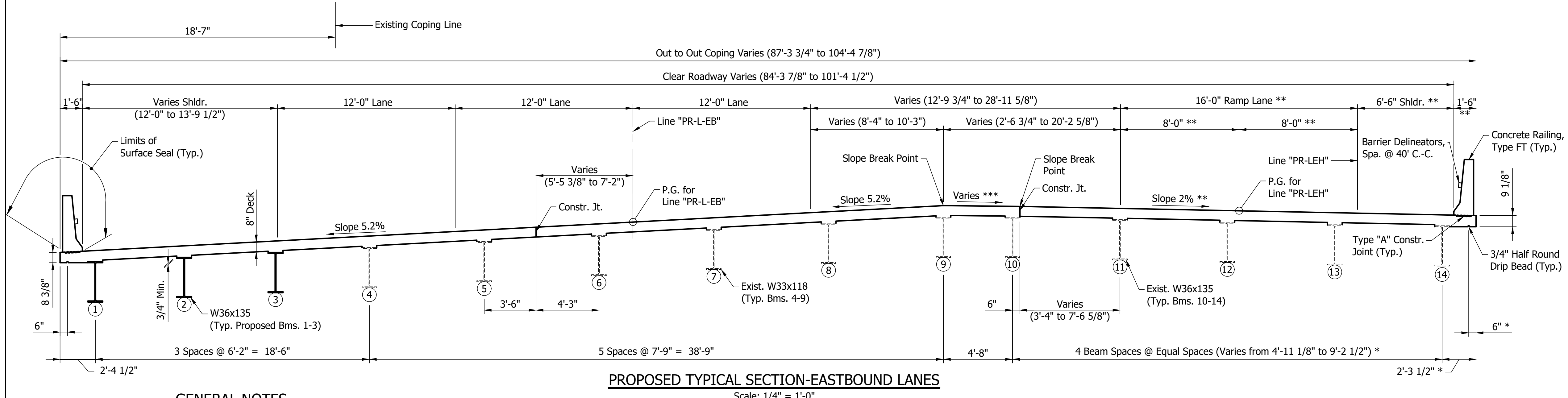

**PROPOSED TYPICAL SECTION-EASTBOUND LANES**  
Scale: 1/4" = 1'-0"

**GENERAL NOTES**

- Reinforcing bar covering shall be 2 1/2" in top and 1" minimum in the bottom of the floor slab, 3" in footings except for bottom bars which shall be 4" and 2" in all other parts, unless otherwise noted.
- Reinforcing bars in deck, barrier, end bent diaphragms and end bent caps shall be epoxy coated, unless otherwise noted.
- All faces of the concrete railing to be sealed in accordance with Article 702.21 of the Specifications. (Estimated Quantity = XXXX Sft.)
- Where new work is to be fitted to the old work, the Contractor shall check and verify all dimensions, elevations and conditions in the field and report any errors or discrepancies to the Engineer and assume responsibility for their correctness and the fit of the new construction to the existing structure.
- Portions of present structure to be removed.
- Data shown for existing bridge and subsequent geometry for proposed structure taken from original structure plans.
- Plans for existing structure are on file in the Research and Documents Section at the Indiana Department of Transportation, as Bridge File No. I-265-0-5513 and are available upon request. The existing bridge bridge was built and alignment was established under Road Contract No. 8872 & 13754.
- Epoxy resin adhesive shall be used where new concrete abuts existing concrete.

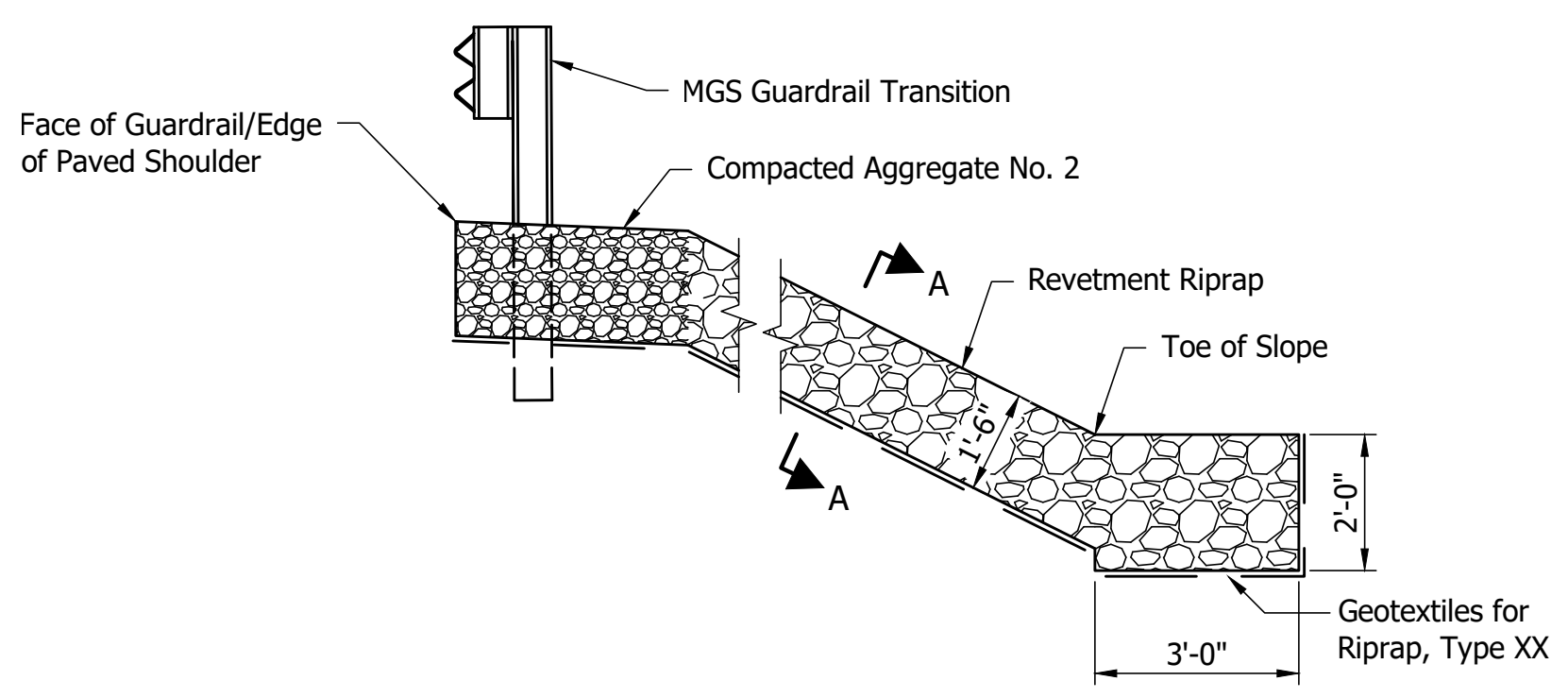

**LONGITUDINAL SECTION**

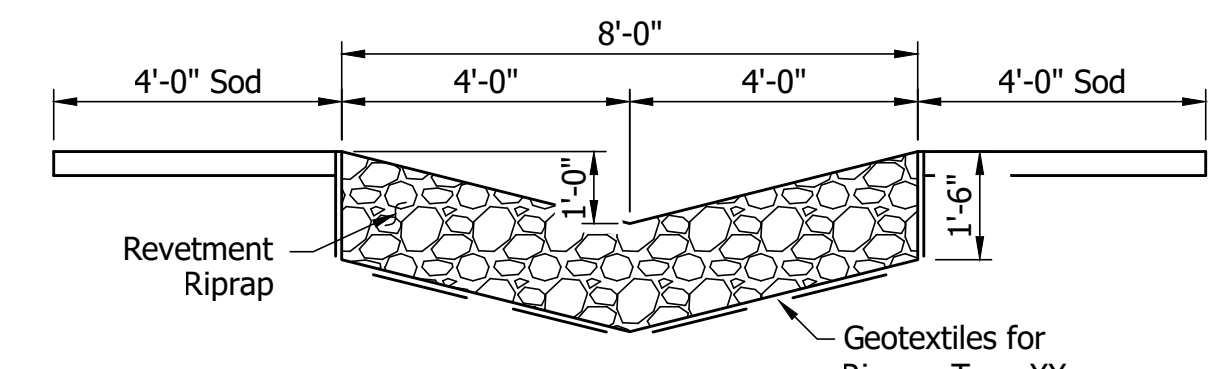

**SECTION A-A**

**Note to Reviewer:**

- Seismic Data will be provided at a later submittal when the Geotechnical Investigation is available.
- Geotextile Type to be provided when Geotechnical Report is complete
- Surface Seal Quantity to be provided at Stage 3

**RIPRAP DRAINAGE TURNOUT DETAIL**  
Scale: 3/8" = 1'-0"

**DRAFT**  
NOT FOR CONSTRUCTION

RECOMMENDED FOR APPROVAL	DESIGN ENGINEER	DATE
DESIGNED: SJM	DRAWN: JF	
CHECKED: TSW	CHECKED: SJM	

INDIANA DEPARTMENT OF TRANSPORTATION	
GENERAL PLAN TYPICAL SECTIONS	

HORIZONTAL SCALE	BRIDGE FILE
AS NOTED	I265-00-05513 JCEB & DRCB
VERTICAL SCALE	DESIGNATION
AS NOTED	2000326 & 2000323
DRAWING NO.	SHEETS
S4 of S6	13 of 18
CONTRACT	PROJECT
R-42570	1900162

PROJECT	DESIGNATION
1900162	2000324
CONTRACT	BRIDGE FILE
R-42570	I265-00-05513 DWBL

# INDIANA DEPARTMENT OF TRANSPORTATION

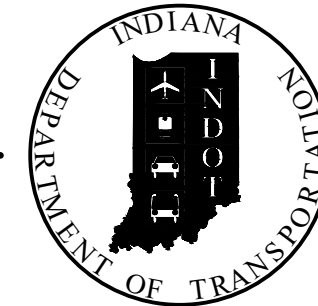

STRUCTURE INFORMATION				
STRUCTURE	TYPE	SPAN AND SKEW	OVER	STATION
I265-00-05513 DWBL	CONTINUOUS COMPOSITE STEEL BEAM BRIDGE	3 SPANS @ 31'-6", 69'-3", 31'-6" SKEW: 11°52'53" RT	STATE STREET	± STRUCTURE Sta.3019+21.97 "PR-L-WB"

## BRIDGE PREVENTIVE MAINTENANCE PLANS

FOR SPANS OVER 20 FEET  
ROUTE: I-265 WB AT: RP 0+98

PROJECT NO. 2000324 P.E.  
1900162 R/W  
2000324 CONST.

Bridge Deck Overlay on I-265 WB over State Street  
Located 0.84 Miles East of I-64 in Sections 27 & 28, T-2-S, R-6-E,  
New Albany Township, Floyd County, Indiana

DESIGNATION	PROJECT DESCRIPTION		LEAD DES.
ROAD			
1900162	I-64 ATL		
1900366	US 150 and Old Vincennes Road (East)		
2100019	I-64 Lighting US 150 to I-64 / I-265		
BRIDGE			
1800706	Bridge Painting on US 150 EB over I-64, Str.No. 150-22-04983 AEBL	STR. 1	
1800405	Bridge Painting on US 150 EB over I-64, Str.No. 150-22-04983 AWBL	STR. 2	
1700207	Bridge Replacement on I-64 EB over Quarry Road, Str.No. I64-120-10786	STR. 3	
2200015	Bridge Replacement on I-64 WB over Quarry Road, Str.No. I64-120-10742	STR. 4	
1702617	Bridge Replacement on I-64 WB over I-64 EB to I-265 EB Ramp, Str.No. I64-121-10787	STR. 5A	
2200016	New Bridge on I-64 EB over I-64 EB Ramp to I-265 EB, Str.No.I64-121-10743 EBL	STR. 5B	
1800721	Bridge Replacement on I-64 WB over I-265 WB Ramp to I-64 EB, Str.No.I64-121-10788	STR. 6	
2200019	Bridge Replacement on I-265 WB to I-64 EB Ramp over I-64 EB to I-265 EB Ramp, Str.No.(I64)I265-00-10746	STR. 7	
2200017	Bridge Replacement on I-64 EB over Captain Frank Road, Str.No.I64-121-10744	STR. 8	
2200018	Superstructure Replacement on I-64 WB over Captain Frank Road, Str. No. I64-121-04986 DWBL	STR. 9	
1702614	Bridge Deck Overlay on I-64 over Cherry Street, Str.No. I64-122-04988 D	STR. 10	
2000326 / 2000323	Bridge Deck Replacement & Widening on I-265 EB & Ramp Over State Street, Str.No. I265-00-05513 JCEB & DRCB	STR. 11	
2000324	Bridge Deck Overlay on I-265 WB Over State Street, Str.No. I265-00-05513 DWBL	STR. 12	
1700206	Bridge Deck Replacement I-64 EB over SR 62/ SR 64	STR. 13	
1700205	Bridge Deck Replacement on I-64 WB over SR 62/ SR 64	STR. 14	
2000144	Bridge Deck Overlay on I-64 EB over Yenowine Lane	STR. 15	
2000145	Bridge Deck Overlay on I-64 WB over Yenowine Lane	STR. 16	
2002072	US 150 EB over Little Indian Creek, Str.No.150-22-05230 CEB	STR. 18	
2002073	US 150 WB over Little Indian Creek, Str.No.150-22-05230 CWB	STR. 19	
2200719	I-64 EB & WB over SR 62 / Spring Street, Str.No.I64-123-04689 C	STR. 20	
2200718	I-64 WB Off-Ramp to Spring Street over I-64 WB On-Ramp from Spring Street, Str.No.I64-123-04688 D	STR. 21	
DRAINAGE			
TBD	US 150 Twin Arch Pipe Liner	STR. 17	
TBD	Valley View Creek (6 Small Structures and 7 Small Pipe Replacements)		
TBD	Valley View Creek CMP Liner		
TBD	UNT to Little Indian Creek CMP Liner		
TBD	Hill Brook CMP Liner		
TBD	Small Pipes CMP Liners (2)		

BEGIN CONSTRUCTION  
Sta.1025+38.31 Line "PR-U-WB"

BEGIN PROJECT  
Sta.1180+86.02 Line "PR-A-EB"

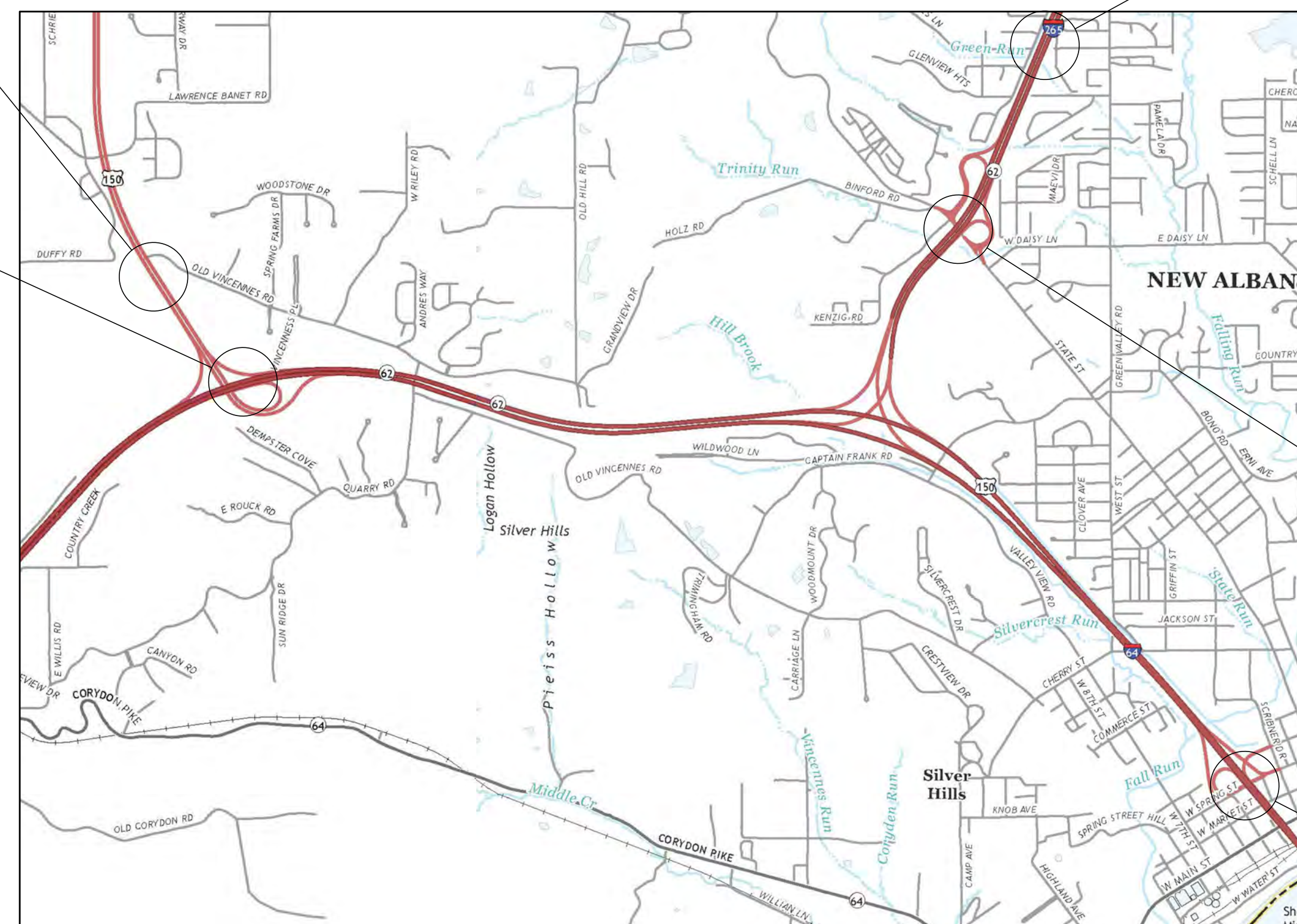

END CONSTRUCTION  
Sta.2077+97.42 Line "PR-L-EB"

STRUCTURE LOCATION  
± Str.-Sta.3019+21.97 Line "PR-L-WB"

END PROJECT  
Sta.1393+50.00 Line "PR-A-EB"

LOCATION MAP  
SCALE: 1" = 2000'

TRAFFIC DATA		I-265 MAINLINE	STATE STREET
A.A.D.T.	(2019)	63,860 V.P.D.	27,200 V.P.D.
A.A.D.T.	(2046)	82,080 V.P.D.	34,300 V.P.D.
D.H.V	(2046)	7,180 V.P.H.	2,980 V.P.H.
DIRECTIONAL DISTRIBUTION		53 %	55 %
TRUCKS		8 % A.A.D.T. 6 % D.H.V.	2 % A.A.D.T. 2 % D.H.V.

DESIGN DATA		
DESIGN SPEED	65 M.P.H.	
PROJECT DESIGN CRITERIA	4R (FREEWAY)	NO IMPROVEMENT
FUNCTIONAL CLASSIFICATION	URBAN INTERSTATE	
RURAL/URBAN	URBAN	
TERRAIN	ROLLING	
ACCESS CONTROL	FULL	

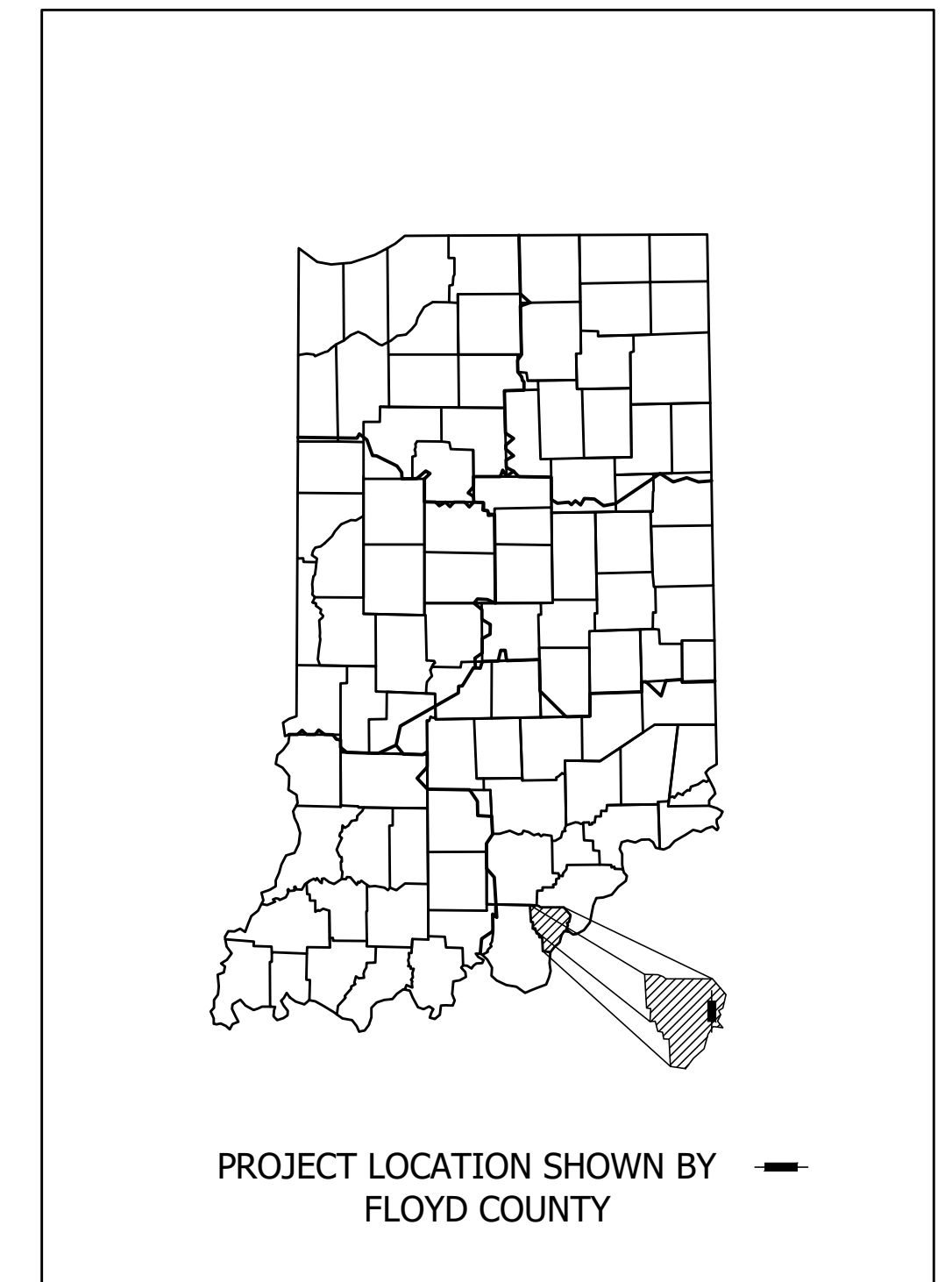

LATITUDE: 38°18'39.71" N LONGITUDE: 85°50'45.17" W

BRIDGE LENGTH: 0.025 MI.  
ROADWAY LENGTH: \* MI.  
TOTAL LENGTH: \* MI.  
MAX. GRADE: 3.00 %  
\* SEE DES. NO. 1900162

HUC 12: 051401010904  
HUC 14: 05140101150020

Note to Reviewer:  
The list of Kinned Projects is tentative and subject to change at INDOT Seymour District's direction. This list represents the current understanding of the Contract Package

### STAGE 2 PLANS

PLANS PREPARED BY:



DRAFT  
NOT FOR CONSTRUCTION

PLANS PREPARED BY: BEAM, LONGEST & NEFF, LLC (317)849-5832 PHONE NUMBER  
CERTIFIED BY: \_\_\_\_\_ DATE  
APPROVED FOR LETTING: \_\_\_\_\_ DATE  
INDIANA DEPARTMENT OF TRANSPORTATION

BRIDGE FILE	
I265-00-05513 DWBL	
DESIGNATION	
2000324	
DRAWING NO.	SHEETS
1	of 13
CONTRACT	PROJECT
R-42570	1900162

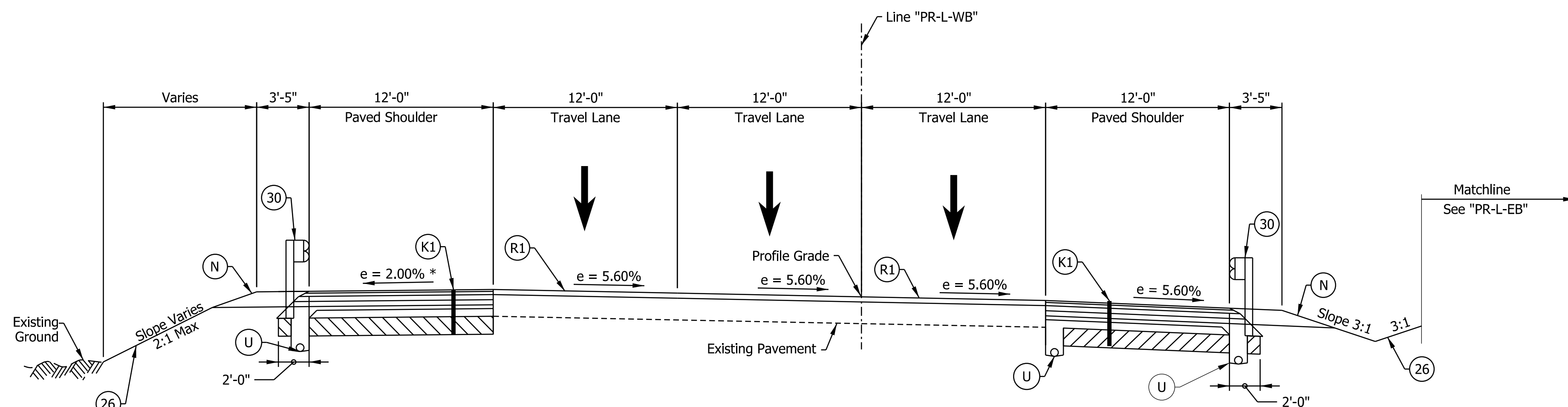

**I-265 WB TYPICAL SUPERELEVATED SECTION**  
 STA. 3011+37.00 "PR-L-WB" TO STA. 3014+00.00 "PR-L-WB"

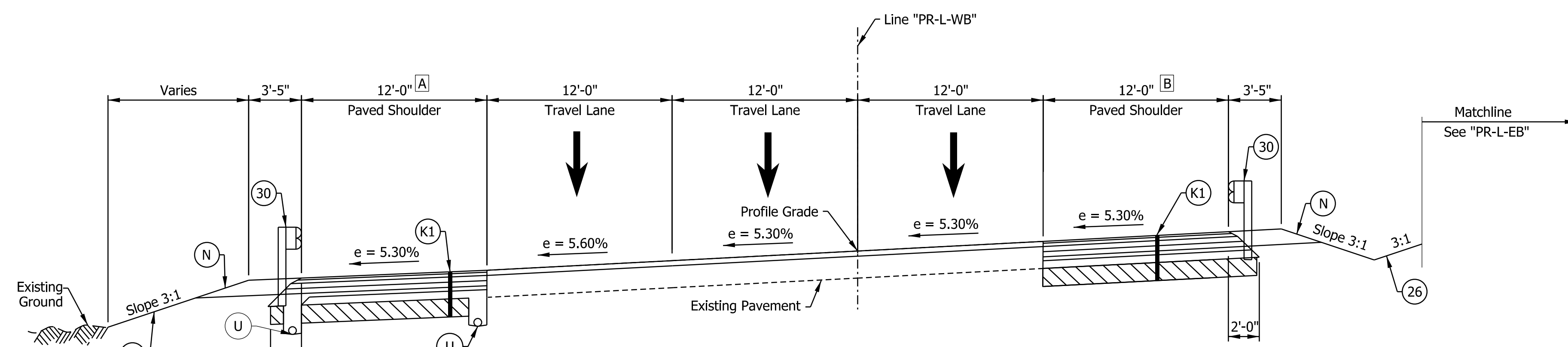

**I-265 WB SUPERELEVATED TYPICAL SECTION**  
 STA. 3018+00.00 "PR-L-WB" TO STA. 3019+89.62 "PR-L-WB"  
 Bridge Paving Exception Sta. 3018+29.09 to Sta. 3020+14.43

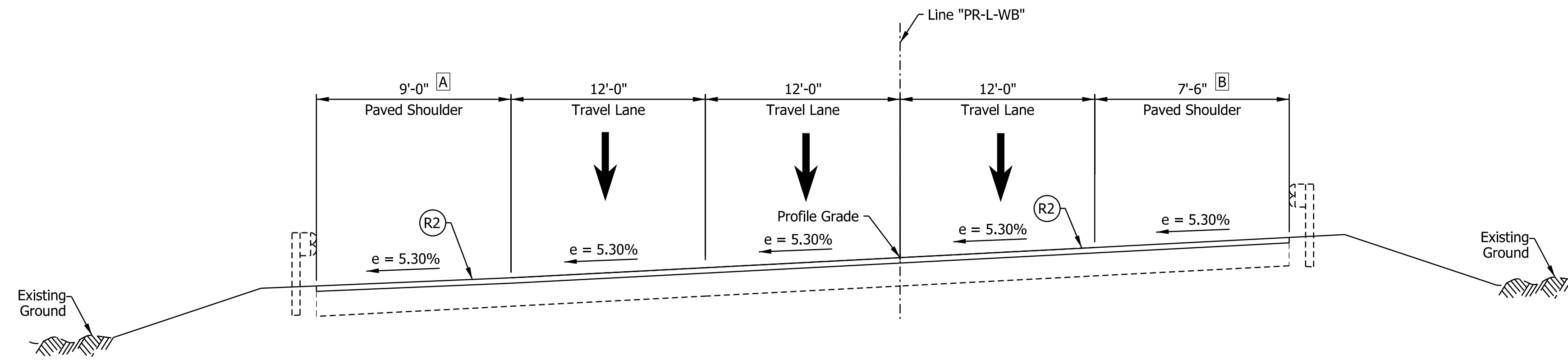

**I-265 WB SUPERELEVATED TYPICAL SECTION**  
 STA. 3019+89.62 "PR-L-WB" TO STA. 3021+14.43 "PR-L-WB"

- Notes:
- See Sheet LGD-01 for construction legend
  - See Sheet TS-43 for Safety Edge Details
  - \* Max rollover between shoulder and travel lane not to exceed 8%.
  - A** Shoulder width varies from 12'-0" at Sta. 3017+00 to 9'-0" at Sta. 3018+28  
Shoulder width varies from 8'-0" at Sta. 3020+15 to 9'-0" at Sta. 3021+14.43
  - B** Shoulder width varies from 12'-0" at Sta. 3017+00 to 7'-6" at Sta. 3018+28  
Shoulder width varies from 7'-6" at Sta. 3020+15 to 4'-6" at Sta. 3021+14.43

**FOR INFORMATION ONLY**

**NOTE TO REVIEWER**  
 Underdrain pipe locations and details to be provided in a future submittal

**DRAFT**  
 NOT FOR CONSTRUCTION

RECOMMENDED FOR APPROVAL	DESIGN ENGINEER	DATE
DESIGNED: DFK	DRAWN: DTC	
CHECKED: ADR	CHECKED: ADR	

INDIANA DEPARTMENT OF TRANSPORTATION  
**I-265 WESTBOUND MAINLINE PROPOSED TYPICAL SECTIONS**

HORIZONTAL SCALE	BRIDGE FILE
3/16"=1'-0"	N/A
VERTICAL SCALE	DESIGNATION
N/A	1900162
SURVEY BOOK	SHEETS
ELECTRONIC	3 of 13
CONTRACT	PROJECT
R-42570	1900162

rsthiegl  
 12/5/2022; 7:01:06 PM  
 model: TYP-05 [Sheet]  
 file: p:\i-265\lhb\org\mg\Great\_Lakes\Documents\Indianapolis\Projects\78704 INDOT-S I-64 ATL\00 CAD-ORD\Sheets\Roadway\1900162\_L\_S\_TYP04.dgn

rstriegel  
 12/15/2022 7:31:21 PM  
 model: PLN-02 [Sheet]  
 file: p:\i\p\in\hmb\org\PM\Great\_Lakes\Documents\Indianapolis\Projects\78704 INDOT-S I-64 ATL 00 CAD-ORD\Sheets\Roadway\1900162\_S\_PLN006.dgn

**FOR INFORMATION ONLY**

+62.4, 116.1 Post  
 3010+64.4, 120.9 Post  
 +89.5, 275.7 Post  
 +95.1, 123.3 Sgl. Post Sign  
 3011+26.9, 129.2 Light Pole  
 +76.9, 139.4 Light Pole  
 +62.4, 275.4 Post  
 +69.2, 122.5 Post

SEC. 28-T25-R6E  
NEW ALBANY TOWNSHIP  
FLOYD COUNTY

SEC. 27-T25-R6E  
NEW ALBANY TOWNSHIP  
FLOYD COUNTY

SEC. 28-T25-R6E  
NEW ALBANY TOWNSHIP  
FLOYD COUNTY

SEC. 27-T25-R6E  
NEW ALBANY TOWNSHIP  
FLOYD COUNTY

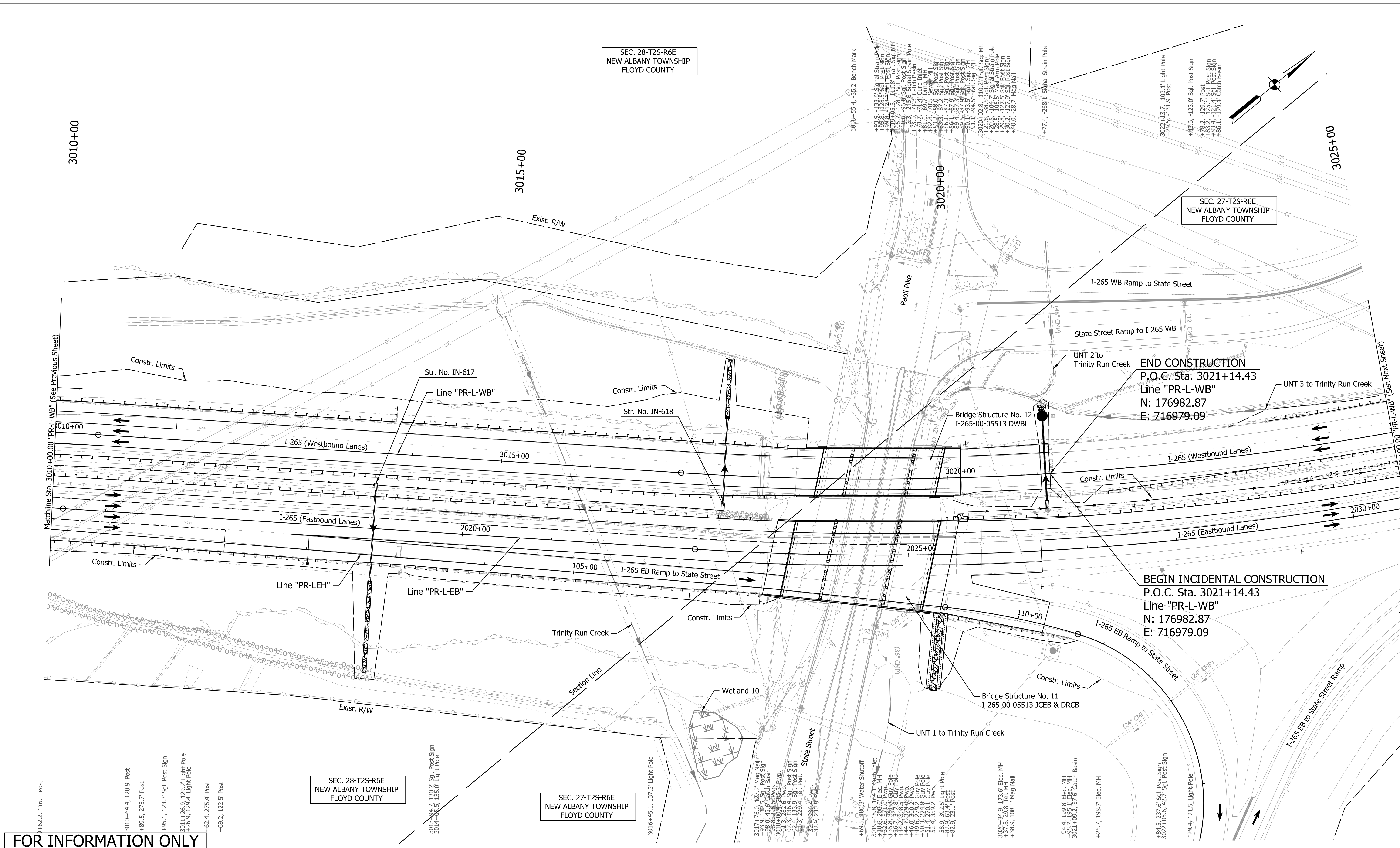

**DRAFT**  
NOT FOR CONSTRUCTION

RECOMMENDED FOR APPROVAL	DESIGN ENGINEER	DATE
DESIGNED: SGM	DRAWN: RJS	
CHECKED: KRC	CHECKED: KRC	

INDIANA  
 DEPARTMENT OF TRANSPORTATION  
  
 PLAN SHEET  
 LINE "PR-L-WB"  
 STA. 3010+00 TO STA. 3025+00

HORIZONTAL SCALE	BRIDGE FILE
1"=50'	N/A
VERTICAL SCALE	DESIGNATION
N/A	1900162
SURVEY BOOK	SHEETS
ELECTRONIC	4 of 13
CONTRACT	PROJECT
R-42570	1900162

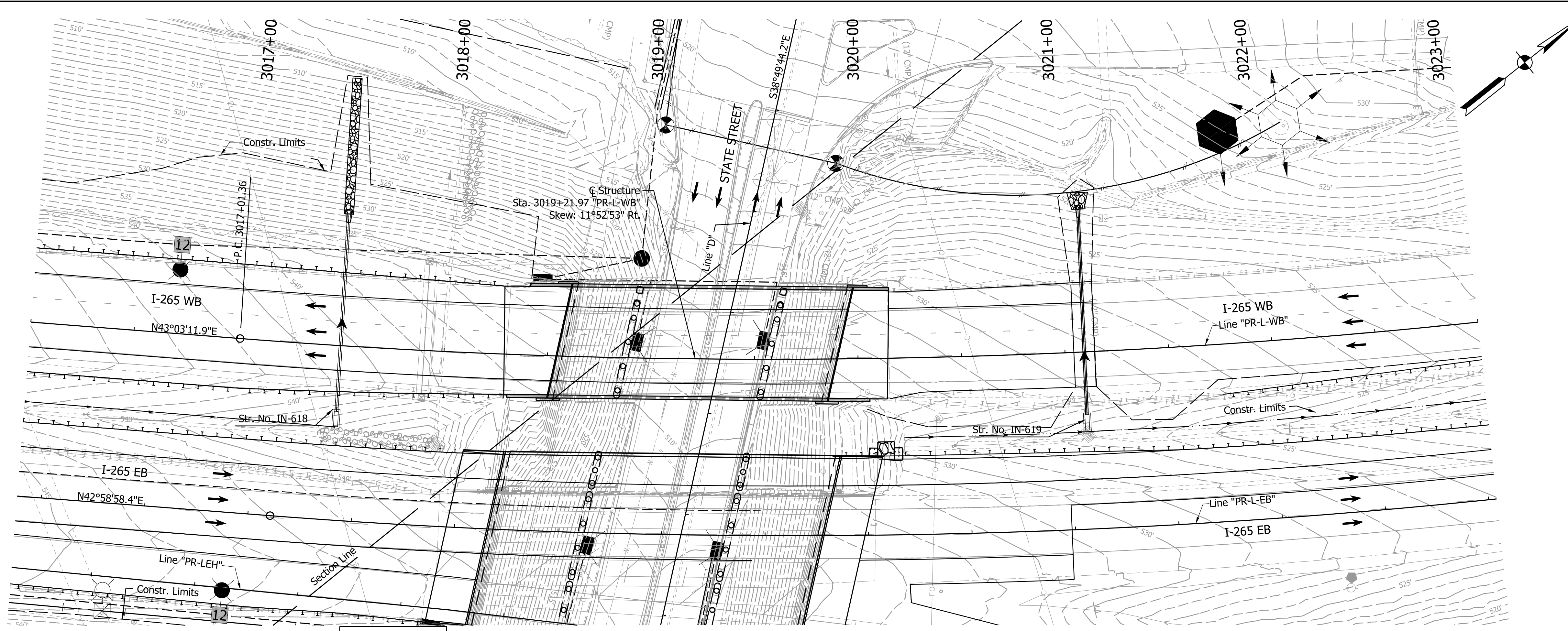

**EXISTING STRUCTURE**  
 Existing Structure (I265-00-05514 CWBL) is a  
 Three-span (31'-6", 69'-3" & 31'-6")  
 Continuous Composite Steel Beam Bridge With  
 A 52'-3/4" Clear Roadway  
 (To Be Rehabilitated)

**EARTHWORK TABULATION**  
 For Earthwork Summary, See Road Plans Des. No. 1900162

**HORIZONTAL CURVE DATA FOR LINE "PR-L-WB"**

**CURVE 32**  
 P.I. 3022+88.53 "PR-L-WB"  
 $\Delta = 20^\circ 21' 41.37''$  LT  
 $D = 01^\circ 45' 08.50''$   
 $R = 3269.63'$   
 $T = 587.17'$   
 $L = 1161.95'$   
 $E = 52.30'$   
 $e = 5.30\%$

**NOTES:**  
 For Reference Ties and Benchmarks,  
 See Road Plans Des. No. 1900162.  
 For Ditch Grades & Guardrail Limits,  
 See Plan & Profile Sheet of Road Plans, Des. No. 1900162.  
 For existing and proposed utilities, drainage, lighting, signing,  
 and ITS, see Des. No. 1900162.

**CONTINUOUS STEEL BEAM BRIDGE**  
 3 SPANS: 31'-6", 69'-3" & 31'-6"  
 52'-3/4" CLEAR ROADWAY SKEW: 11°52'53" RT.  
 I-265 WB OVER STATE STREET,  
 FLOYD COUNTY

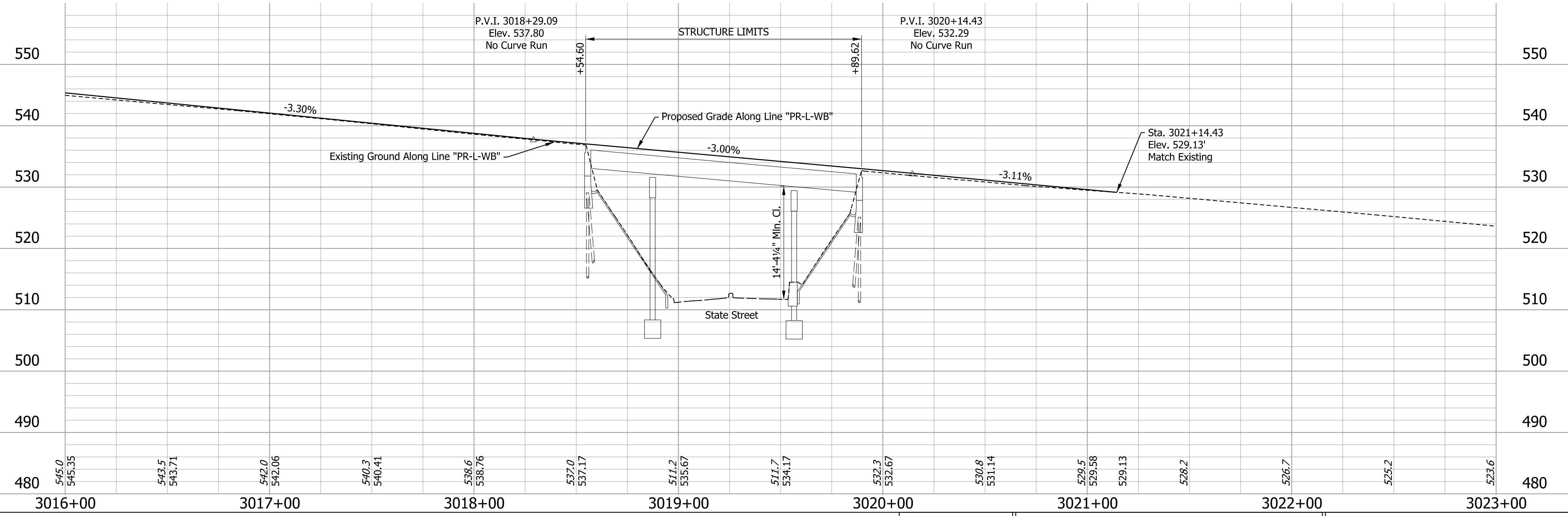

**DRAFT**  
 NOT FOR CONSTRUCTION

RECOMMENDED FOR APPROVAL	DESIGN ENGINEER	DATE
DESIGNED: NDM	DRAWN: JP	
CHECKED: TSW	CHECKED: NDM	

INDIANA  
 DEPARTMENT OF TRANSPORTATION

LAYOUT - LINE "PR-L-WB"

HORIZONTAL SCALE	BRIDGE FILE
1"=30'	I265-00-05514 DWBL
VERTICAL SCALE	DESIGNATION
1"=10'	2000324
DRAWING NUMBER	SHEETS
S1 of S5	7 of 13
CONTRACT	PROJECT
R-42570	1900162

ssmith  
 12/5/2022 10:16:49 AM  
 model: PIN-01 [Sheet]  
 file: p:\i\pin-01\hmb.org\PM\Great\_Lakes\Documents\Indianapolis Projects\78704 INDOT-S I-64 ATL 00 CAD-ORD\Sheets\Bridges\Bridges No. 12 - I-265 SB over State St\1900162\_S\_LAY12.dgn

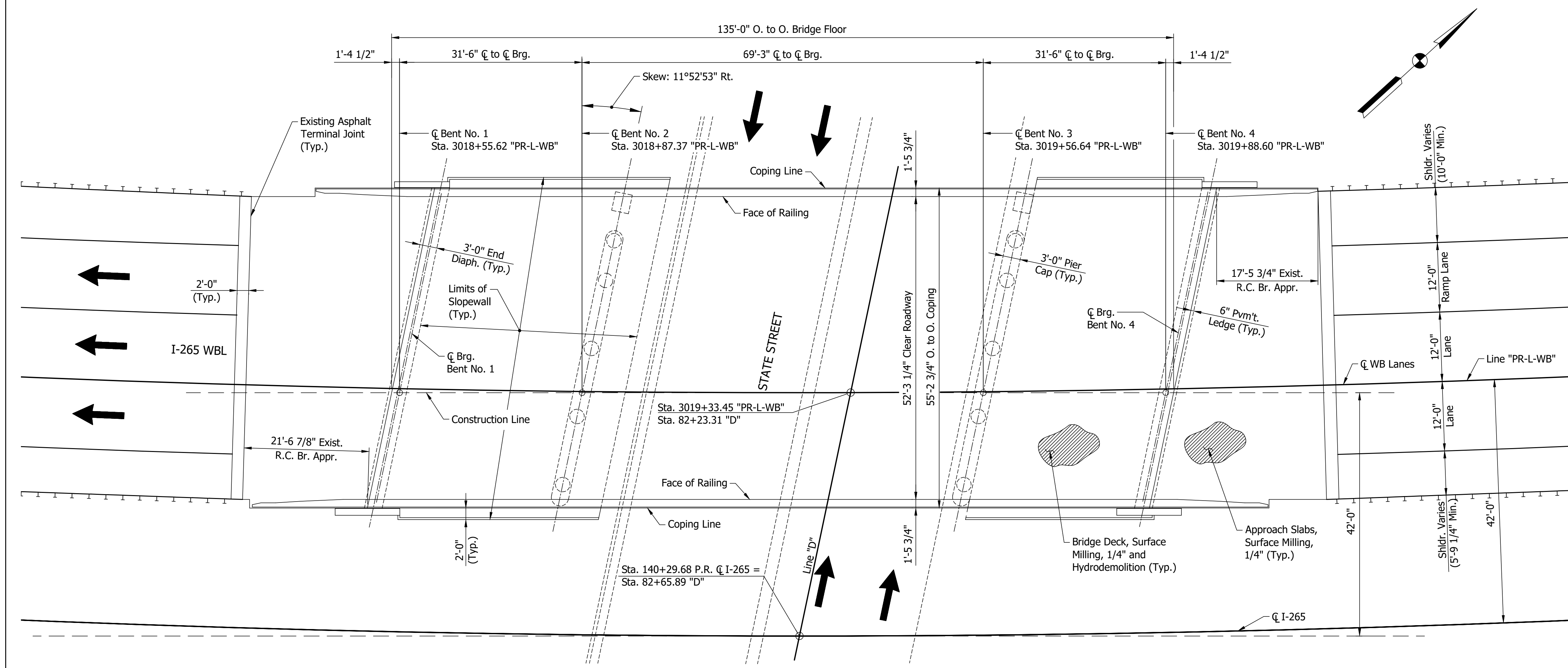
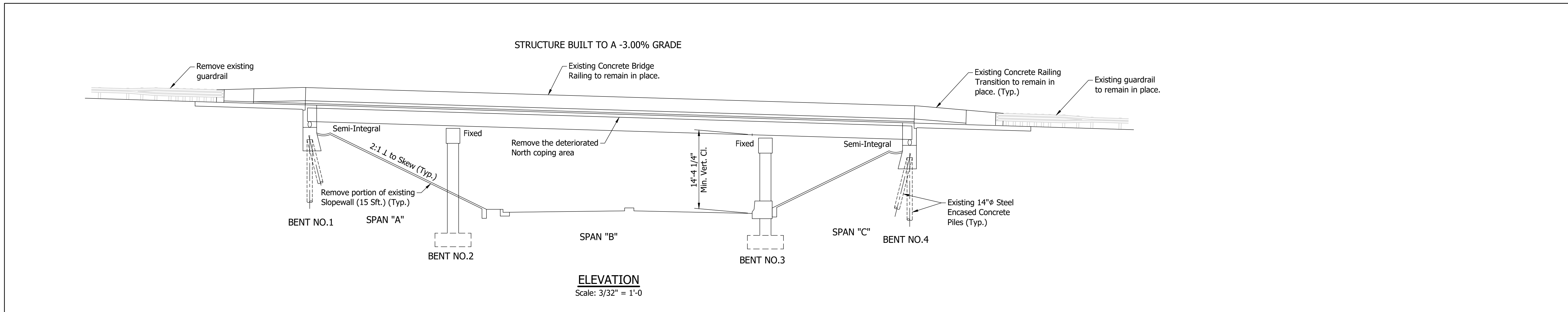

Notes:  
For Typical Section & General Notes, see Dwg. S4.  
For Line "D" information, see Original Plans.

**CONTINUOUS COMPOSITE STEEL BEAM BRIDGE**  
3 SPANS: 31'-6", 69'-3", & 31'-6"  
52'-3 1/4" CLEAR ROADWAY SKEW: 11°52'53" RT.  
I-265 WB OVER STATE STREET  
FLOYD COUNTY

DRAFT NOT FOR CONSTRUCTION	RECOMMENDED FOR APPROVAL _____	DESIGN ENGINEER _____ DATE _____	INDIANA DEPARTMENT OF TRANSPORTATION	HORIZONTAL SCALE AS NOTED	BRIDGE FILE 1265-00-05513 DWBL
	DESIGNED: NDM	DRAWN: JF	GENERAL PLAN EXISTING	VERTICAL SCALE AS NOTED	DESIGNATION 2000324
	CHECKED: TSW	CHECKED: NDM		DRAWING NO. S2 of S5	SHEETS 8 of 13
				CONTRACT R-42570	PROJECT 1900162



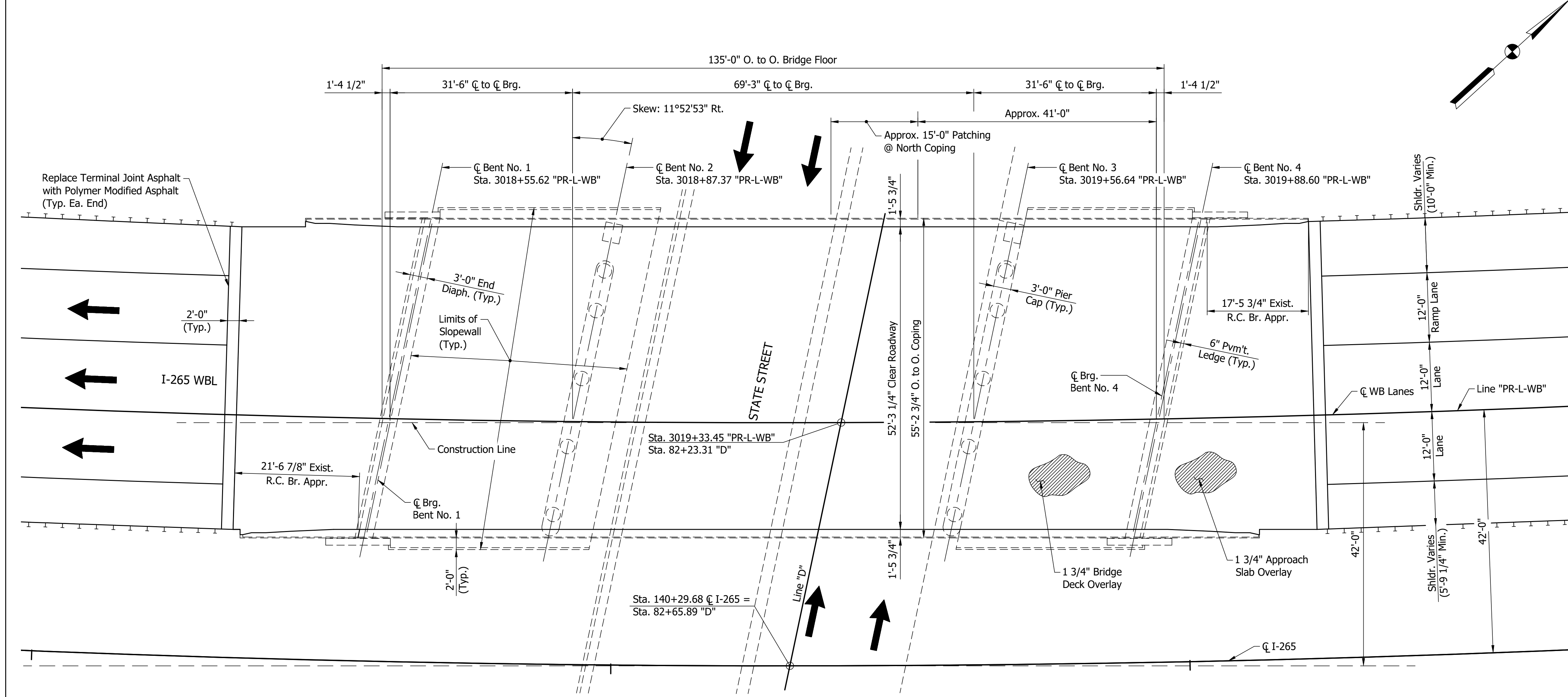
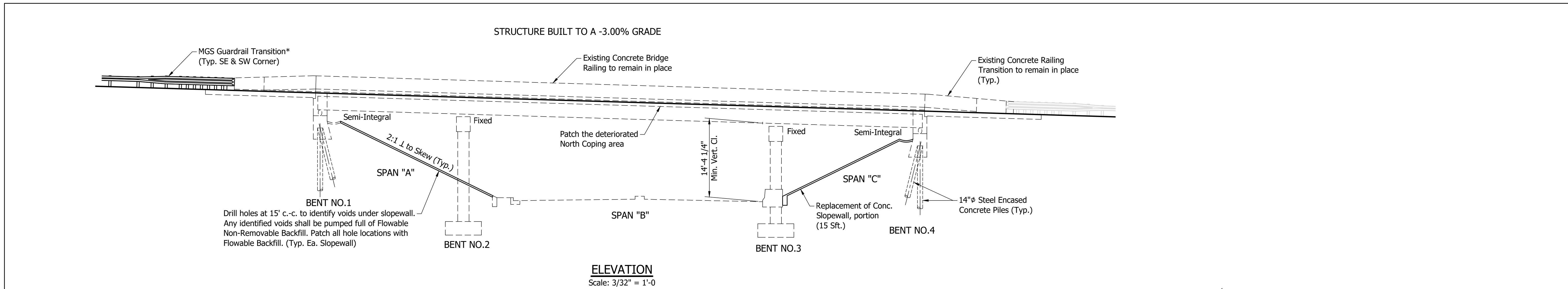

Notes:  
 For Typical Section & General Notes, see Dwg. S4.  
 For pavement transitions on roadway approaches, see Road Plans Des. No. 1900162  
 \* Roadway Item

**CONTINUOUS COMPOSITE STEEL BEAM BRIDGE**  
**3 SPANS: 31'-6", 69'-3", & 31'-6"**  
**52'-3 1/4" CLEAR ROADWAY SKEW: 11°52'53" RT.**  
**I-265 WB OVER STATE STREET**  
**FLOYD COUNTY**

<b>DRAFT</b> NOT FOR CONSTRUCTION	RECOMMENDED FOR APPROVAL _____	DESIGN ENGINEER _____ DATE _____	INDIANA DEPARTMENT OF TRANSPORTATION	HORIZONTAL SCALE AS NOTED	BRIDGE FILE 1265-00-05513 DWBL
	DESIGNED: NDM	DRAWN: JF	<b>GENERAL PLAN</b> <b>PROPOSED</b>	VERTICAL SCALE AS NOTED	DESIGNATION 2000324
	CHECKED: TSW	CHECKED: NDM		DRAWING NO. S3 of S5	SHEETS 9 of 13
				CONTRACT R-42570	PROJECT 1900162

**GENERAL NOTES**

Reinforcing bar covering shall be 2" in top and 1" minimum in the bottom of the floor slab, and 2" in all other parts, unless noted otherwise.

Where new work is to be fitted to the old work, the Contractor shall check and verify all dimensions, elevations and conditions in the field and report any errors or discrepancies to the Engineer and assume responsibility for their correctness and the fit of the new construction to the existing structure.

All exposed faces of concrete bridge and transition railings to be sealed in accordance with Article 702.21 of the Specifications. (Estimated Quantity = X Sft.)

Plans for existing structure are on file in the Research and Documents Section at the Indiana Department of Transportation, as Bridge File No. I-265-0-5513, I-265-0-5513A, I-265-0-5513B and I-265-0-5513C and are available upon request.

Data shown for the existing bridge and subsequent geometry for the proposed structure was taken from the original structure and rehabilitation plans.

**DESIGN DATA**

**LIVE LOAD**

Designed for HS-20-44 loading in accordance with the 1996 AASHTO Bridge Design Specifications.

**MATERIAL NOTES**

**BRIDGE DECK OVERLAY**

1 3/4" Latex Modified Portland Cement Concrete or  
1 3/4" Silica Fume Modified Structural Concrete

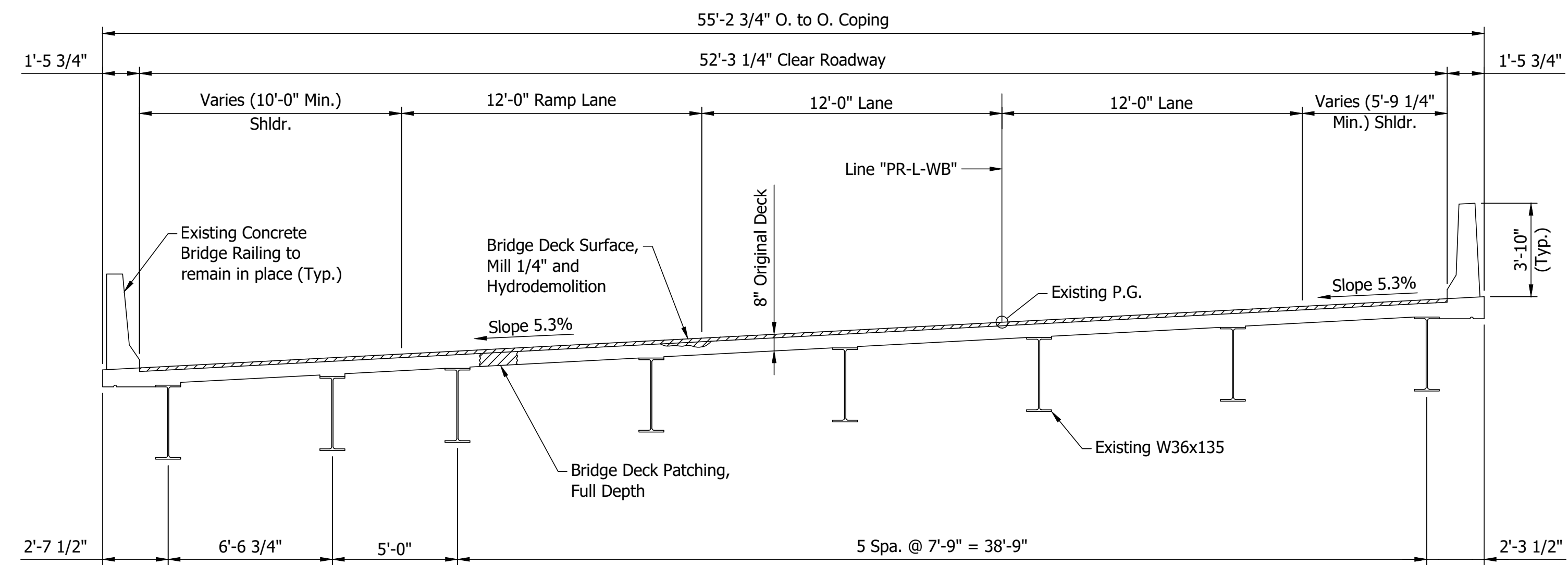

**TYPICAL SECTION-EXISTING WESTBOUND LANES**  
Scale: 1/4" = 1'-0"

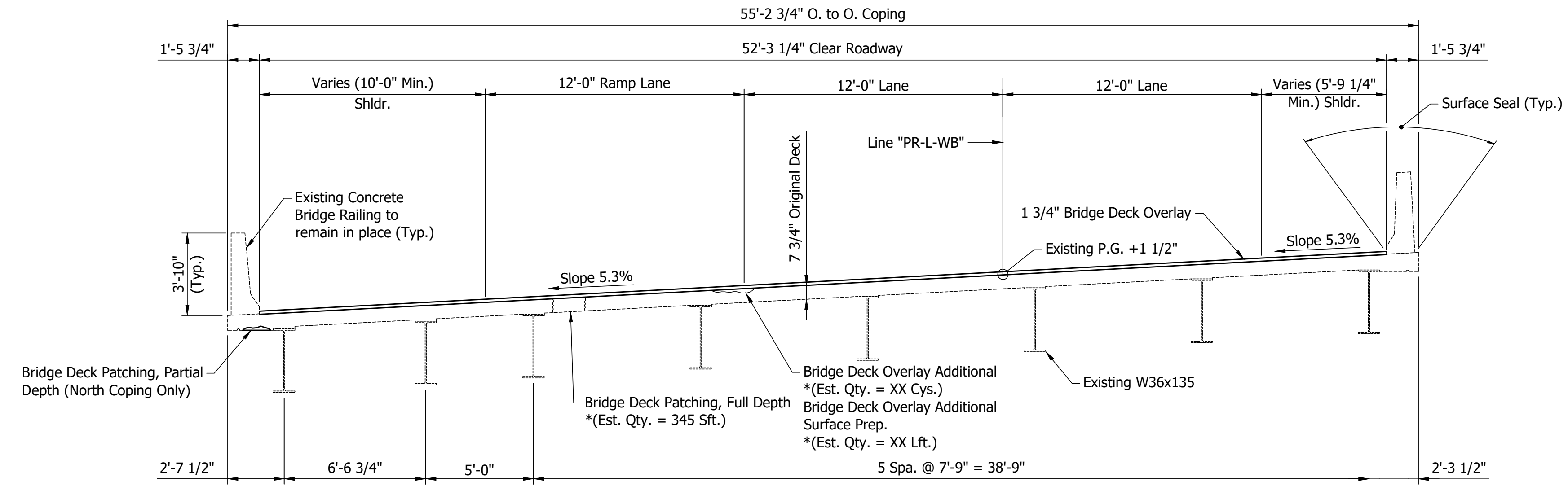

**TYPICAL SECTION-PROPOSED WESTBOUND LANES**  
Scale: 1/4" = 1'-0"

**Note to Reviewer:**  
- Surface Seal Quantity to be provided at Stage 3

Note:  
For Plan & Elevation, see Dwg. S2 & S3.  
\* For Information Only

CONTINUOUS COMPOSITE STEEL BEAM BRIDGE  
3 SPANS: 31'-6", 69'-3", & 31'-6"  
52'-3 1/4" CLEAR ROADWAY SKEW: 11°52'53" RT.  
I-265 WB OVER STATE STREET  
FLOYD COUNTY

**DRAFT**  
NOT FOR CONSTRUCTION

RECOMMENDED FOR APPROVAL	DESIGN ENGINEER	DATE
DESIGNED: NDM	DRAWN: JF	
CHECKED: TSW	CHECKED: NDM	

INDIANA  
DEPARTMENT OF TRANSPORTATION

GENERAL PLAN  
TYPICAL SECTIONS

HORIZONTAL SCALE	BRIDGE FILE
AS NOTED	1265-00-05513 DWBL
VERTICAL SCALE	DESIGNATION
AS NOTED	2000324
DRAWING NO.	SHEETS
S4 of S5	10 of 13
CONTRACT	PROJECT
R-42570	1900162

PROJECT	DESIGNATION
1900162	2200719
CONTRACT	BRIDGE FILE
R-42570	164-123-04689 C

STRUCTURE INFORMATION				
STRUCTURE	TYPE	SPAN AND SKEW	OVER	STATION
I64-123-04689 C	CONTINUOUS STEEL BEAM BRIDGE	3 SPANS: 41'-0", 70'-6", 41'-0" SKEW: 10°34'30" RT.	SPRING STREET	C STRUCTURE STA. 1385+01.18 "PR-A-EB"  C STRUCTURE STA. 2386+50.20 "PR-A-WB"

KIN PROJECT INFORMATION		
DESIGNATION	PROJECT DESCRIPTION	
ROAD		
1900162	Added Travel Lanes on I-64	LEAD DES.
1900366	US 150 and Old Vincennes Road (East)	
2100019	I-64 Lighting US 150 to I-64 / I-265	
BRIDGE		
1800706	Bridge Painting on US 150 EB over I-64	Str. 1
1800405	Bridge Painting on US 150 WB over I-64	Str. 2
1700207	Bridge Replacement on I-64 EB over Quarry Road	Str. 3
2200015	Bridge Replacement on I-64 WB over Quarry Road	Str. 4
1702617	Bridge Replacement on I-64 WB over I-64 Ramp to I-265 EB	Str. 5A
2200016	Bridge Replacement on I-64 EB over I-64 Ramp to I-265 EB	Str. 5B
1800721	Bridge Replacement on I-64 WB over I-265 Ramp to I-64 EB	Str. 6
2200019	Bridge Replacement on I-265 WB to I-64 EB over I-64 EB to I-265 EB	Str. 7
2200017	Bridge Replacement on I-64 EB over Captain Frank Road	Str. 8
2200018	Superstructure Replacement on I-64 WB over Captain Frank Road	Str. 9
1702614	Bridge Deck Overlay on I-64 EB & WB over Cherry Street	Str. 10
2000326 / 2000323	Bridge Deck Replacement and Widening on I-265 EB over State Street	Str. 11
2000324	Bridge Deck Overlay on I-265 WB over State Street	Str. 12
1700205	I-64 WB over SR62 / SR 64	Str. 14
1700206	I-64 EB over SR62 / SR 64	Str. 13
2000144	Bridge Deck Overlay on I-64 EB over Yenowine Lane	Str. 15
2000145	Bridge Deck Overlay on I-64 WB over Yenowine Lane	Str. 16
2002072	US 150 EB over Little Indian Creek	Str. 18
2002073	US 150 WB over Little Indian Creek	Str. 19
2200719	I-64 EB & WB over SR 62 / Spring Street	Str. 20
2200718	I-64 WB Off-Ramp to Spring over I-64 WB On-Ramp from Spring	Str. 21
DRAINAGE		
TBD	US 150 Twin Arch Pipe Liner	Str. 17
TBD	Valley View Creek (6 Small Structure and 7 Small Pipe Replacements)	
TBD	Valley View Creek CMP Liner	
TBD	UNT to Little Indian Creek CMP Liner	
TBD	Hill Brook CMP Liner	
TBD	Small Pipes CMP Liners (2)	

**NOTE TO REVIEWER**  
 The list of KIN'd projects is tentative and subject to change at INDOT Seymour District's direction. This list represents the current understanding of the contract package.

**STAGE 2 PLANS**

# INDIANA DEPARTMENT OF TRANSPORTATION

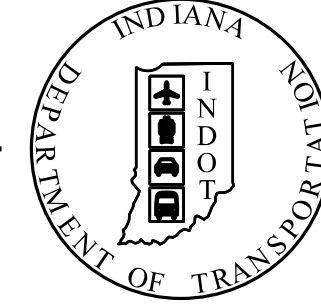

## BRIDGE PREVENTIVE MAINTENANCE PLANS

FOR SPANS OVER 20 FEET  
 ROUTE : I-64 EB/WB AT: RP 123+46

PROJECT NO. 2200719 P.E.  
 1900162 R/W  
 2200719 CONST.

BRIDGE DECK OVERLAY ON I-64 EB/WB OVER SPRING STREET  
 LOCATED 0.18 MILES WEST OF SR 111 IN  
 SECTION 3, T-3-S, R-6-E, NEW ALBANY TOWNSHIP, FLOYD COUNTY, INDIANA

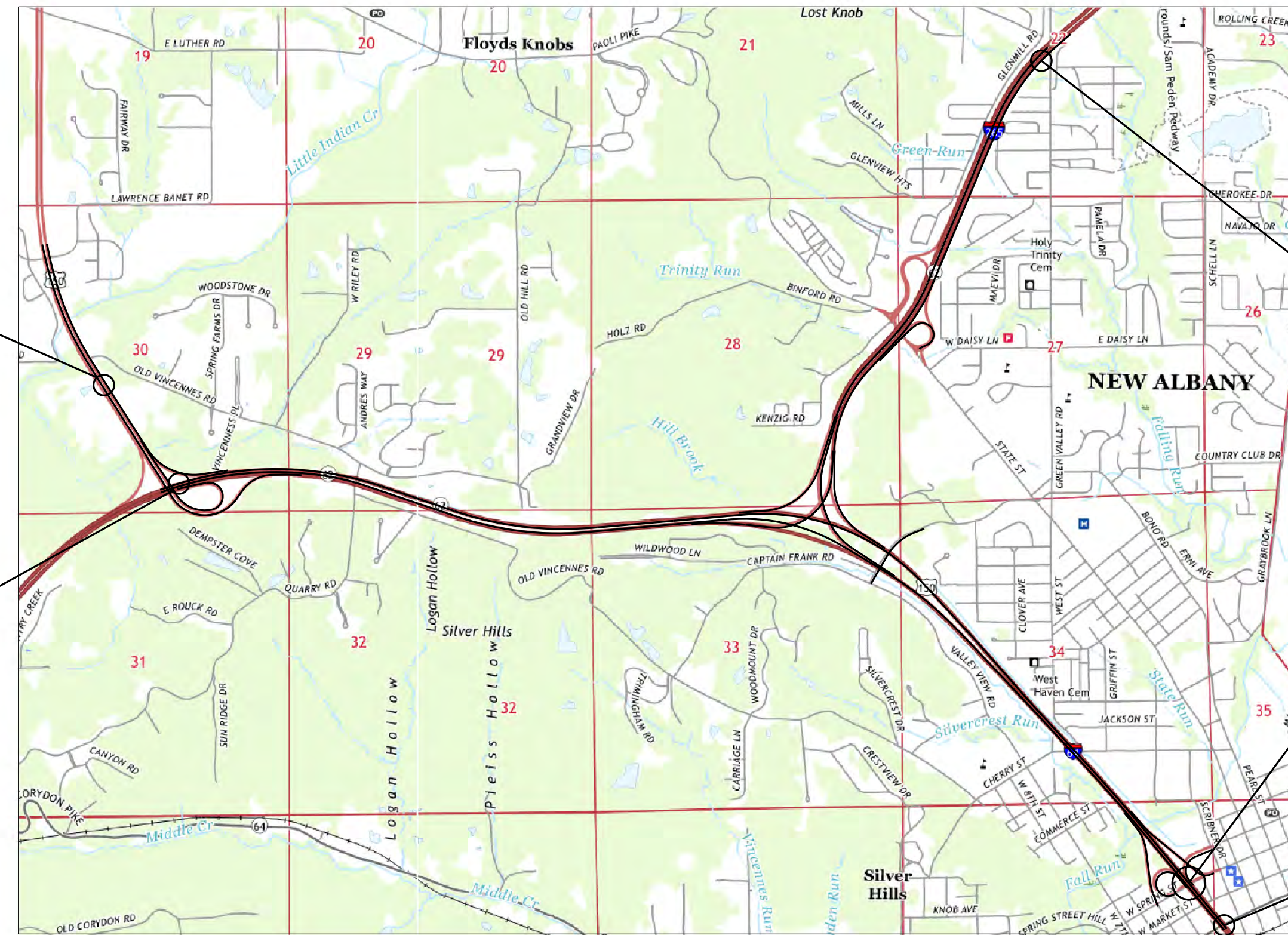

LOCATION MAP  
 FLOYD COUNTY

TRAFFIC DATA	I-64 MAINLINE	SPRING STREET
A.A.D.T. (2019)	77,380 V.P.D.	14,400 V.P.D.
A.A.D.T. (2046)	93,460 V.P.D.	16,560 V.P.D.
D.H.V (2046)	8,910 V.P.H.	1,070 V.P.H.
DIRECTIONAL DISTRIBUTION	67%	80%
TRUCKS	9%	3%
	6% D.H.V.	1% D.H.V.

DESIGN DATA		
DESIGN SPEED	70 M.P.H.	
PROJECT DESIGN CRITERIA	4R (FREEWAY)	NO IMPROVEMENT
FUNCTIONAL CLASSIFICATION	INTERSTATE	
RURAL/URBAN	URBAN	
TERRAIN	ROLLING	
ACCESS CONTROL	FULL	

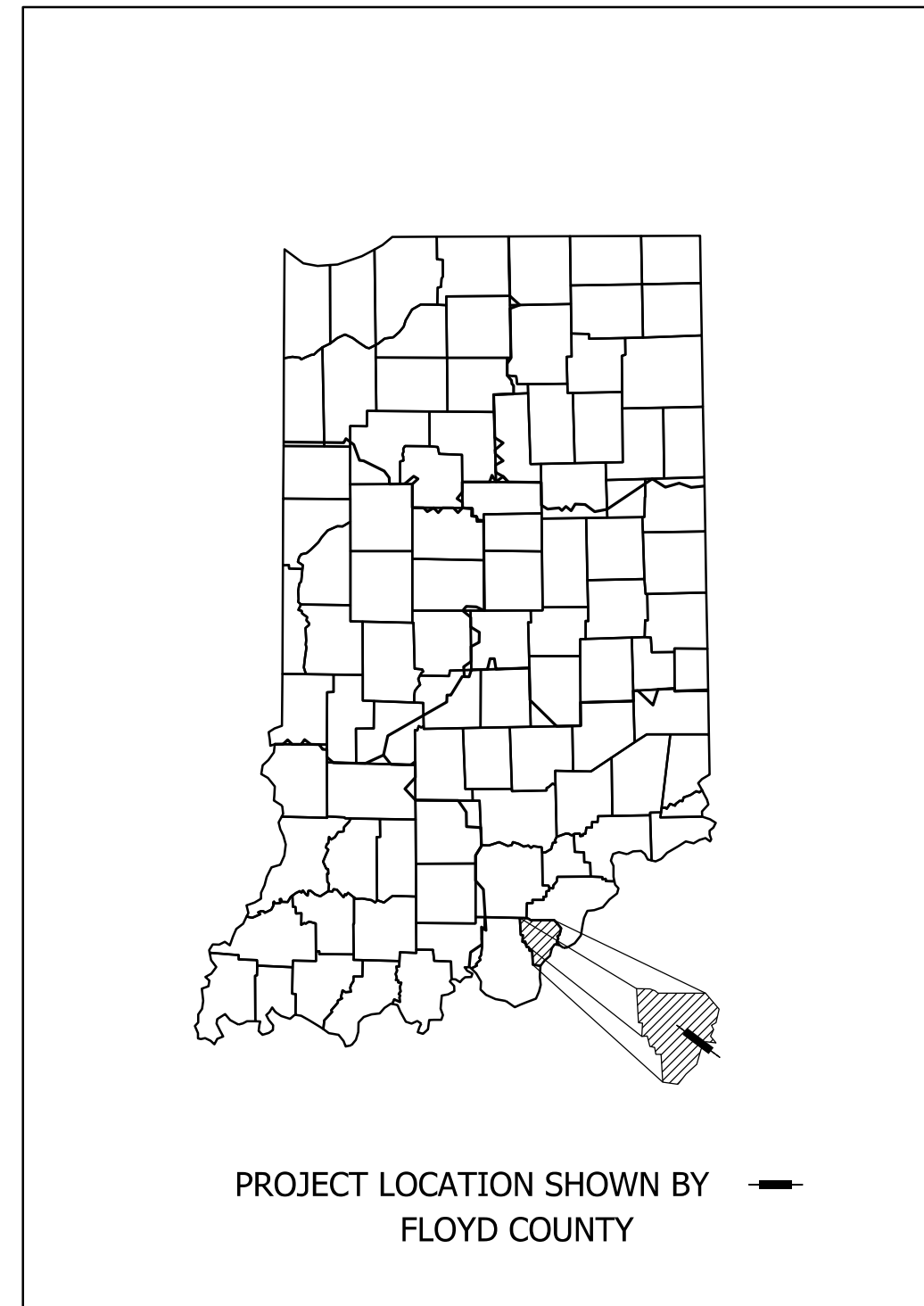

LATITUDE: 38°17'26.7" N LONGITUDE: 85°50'06.4" W

BRIDGE LENGTH: 0.029 MI.  
 ROADWAY LENGTH: \* MI.  
 TOTAL LENGTH: \* MI.  
 MAX. GRADE: 3.000 %  
 \* SEE DES NO. 1900162

12-DIGIT HYDROLOGIC UNIT CODE: 051401010904

INDIANA DEPARTMENT OF TRANSPORTATION  
 STANDARD SPECIFICATIONS DATED 2022  
 TO BE USED WITH THESE PLANS

khamison  
 12/16/2022 11:31:47 AM  
 model: TTL-01 [Sheet]  
 file: p:\i\p\i\hmb\org\PMG\Great\_Lakes\Documents\Indianapolis Projects\78704 INDOT-S I-64 ATL 00 CAD-ORD\Sheets\Bridge\Bridge No. 20 - I-64 EB and WB over Spring\_S\2200719\_S\_TTL-01.dgn



9102 North Meridian Street, Suite 200, Indianapolis, IN 46260  
 Phone: (317) 566-0629

**DRAFT**  
 NOT FOR CONSTRUCTION

PLANS PREPARED BY:	SJCA, INC	(317) 566-0629
		PHONE NUMBER
CERTIFIED BY:		DATE
RECOMMENDED FOR LETTING:		DATE
	INDIANA DEPARTMENT OF TRANSPORTATION	

BRIDGE FILE		
164-123-04689 C		
DESIGNATION		
2200719		
SURVEY BOOK	SHEETS	TTL-01
ELECTRONIC	1 of	13
CONTRACT	PROJECT	
R-42570	1900162	

khamison  
 12/16/2022; 11:32:03 AM  
 model: TYP-01 [Sheet]  
 file: p:\i\p\in\hmb\org\PM\Great\_Lakes\Documents\Indianapolis Projects\78704 INDOT-S I-64 ATL 00 CAD-ORD\Sheets\Bridges\No. 20 - I-64 EB and WB over Spring\_S\2200719\_5\_TYP01.dgn

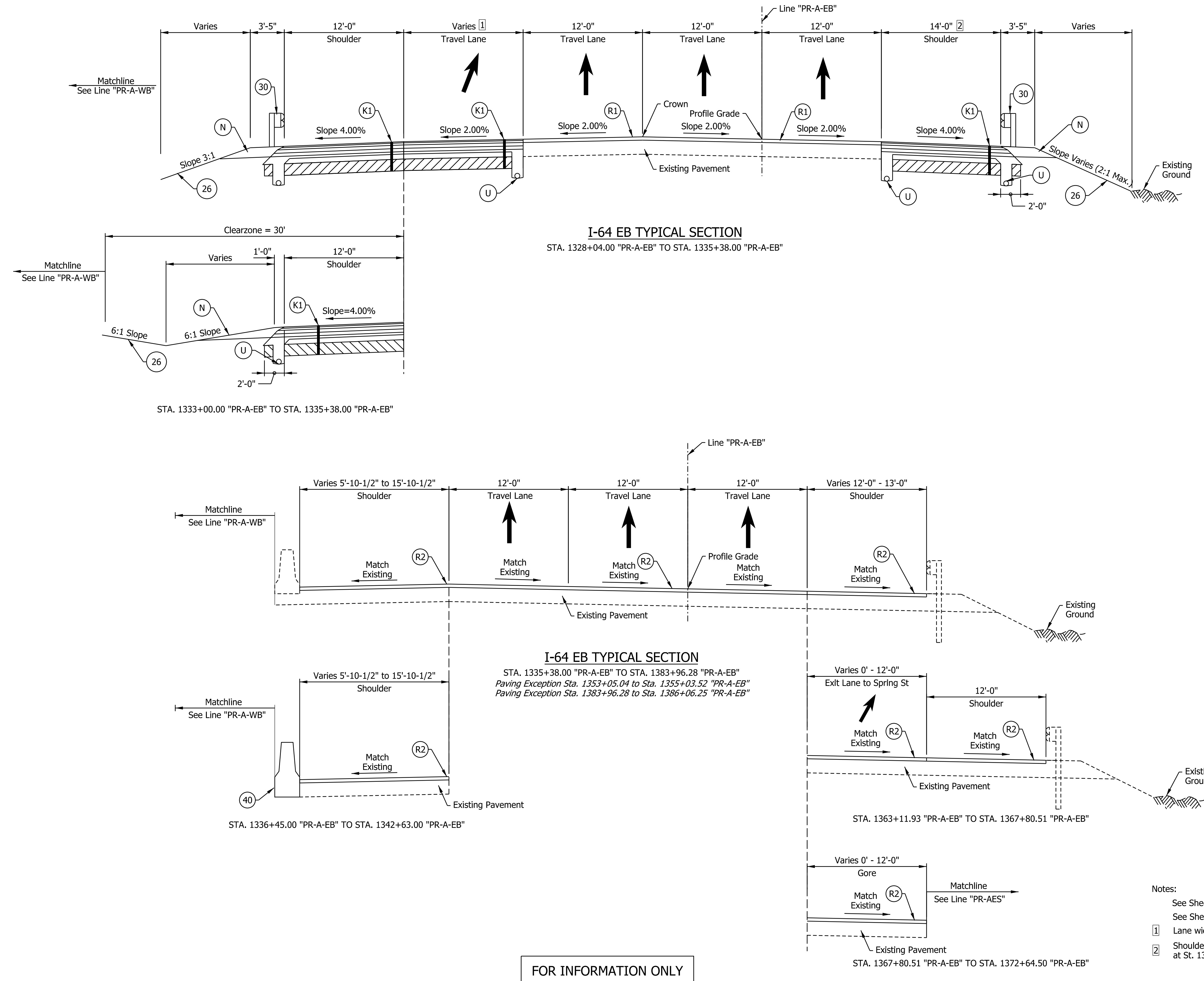

FOR INFORMATION ONLY

- Notes:
- See Sheet LGD-01 for construction legend
  - See Sheet TS-43 for Safety Edge Details
  - ① Lane width varies from 12'-0" at Sta. 1323+93.14 to 0'-0" Sta. 1333+00.00
  - ② Shoulder width varies from 14'-0" at Sta. 1333+00.00 to 12'-0" at St. 1335+38.00

**DRAFT**  
 NOT FOR CONSTRUCTION

RECOMMENDED FOR APPROVAL _____	DESIGN ENGINEER _____	DATE _____
DESIGNED: _____ SGM _____	DRAWN: _____ CGR _____	
CHECKED: _____ ADR _____	CHECKED: _____ ADR _____	

INDIANA  
 DEPARTMENT OF TRANSPORTATION  
  
**I-64 EASTBOUND MAINLINE  
 PROPOSED TYPICAL SECTIONS**

HORIZONTAL SCALE	BRIDGE FILE
3/16" = 1'-0"	164-123-04689 C
VERTICAL SCALE	DESIGNATION
AS NOTED	2200719
SURVEY BOOK	SHEETS TYP-01
ELECTRONIC	3 of 13
CONTRACT	PROJECT
R-42570	1900162

Notes:

- See Sheet LGD-01 for construction legend
- See Sheet TS-43 for Safety Edge Details
- 1 Lane width varies from 12'-0" at Sta. 2334+00.00 to 0'-0" at Sta. 2339+80.00
- 2 Shoulder width varies from 14'-0" at Sta. 2334+00.00 to 10'-10" at Sta. 2339+80.00
- 3 Shoulder width varies, maximum of 19'-6". Match Existing.

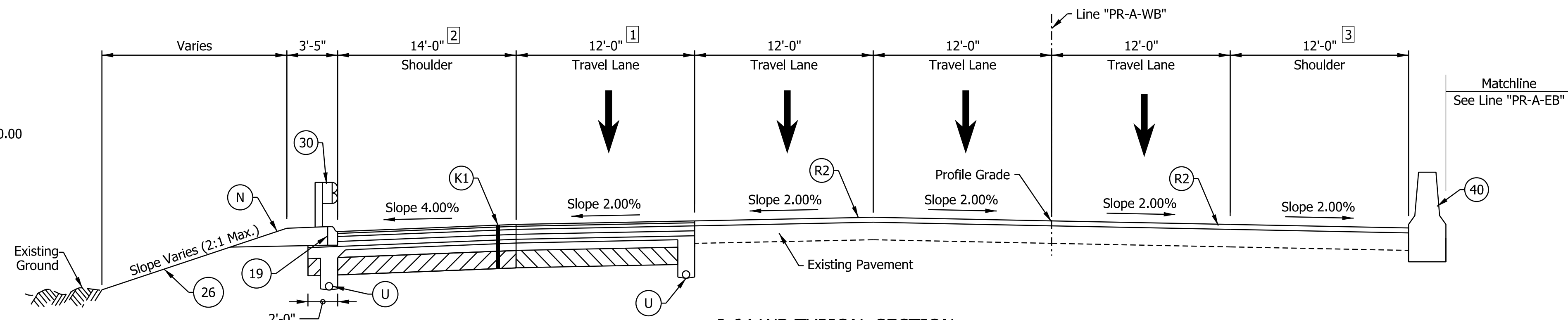

I-64 WB TYPICAL SECTION

STA. 2337+79.00 "PR-A-WB" TO STA. 2339+80.00 "PR-A-WB"

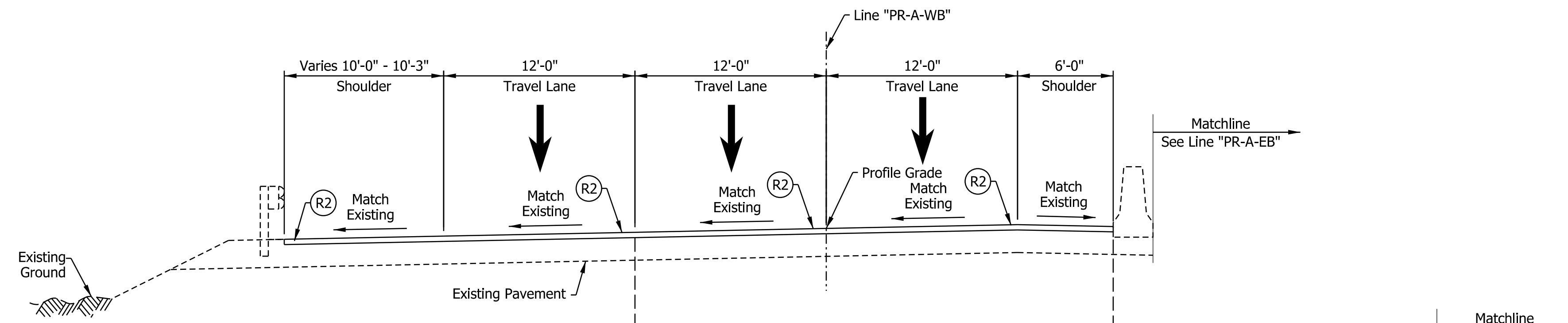

I-64 WB TYPICAL SECTION

STA. 2339+80.00 "PR-A-WB" TO STA. 2385+47.44 "PR-A-WB"  
 Paving Exception Sta. 2354+86.59 to Sta. 2356+85.07 "PR-A-WB"  
 Paving Exception Sta. 2385+47.44 to Sta. 2387+57.40 "PR-A-WB"

STA. 2337+82.00 "PR-A-WB" TO STA. 2344+00.00 "PR-A-WB"

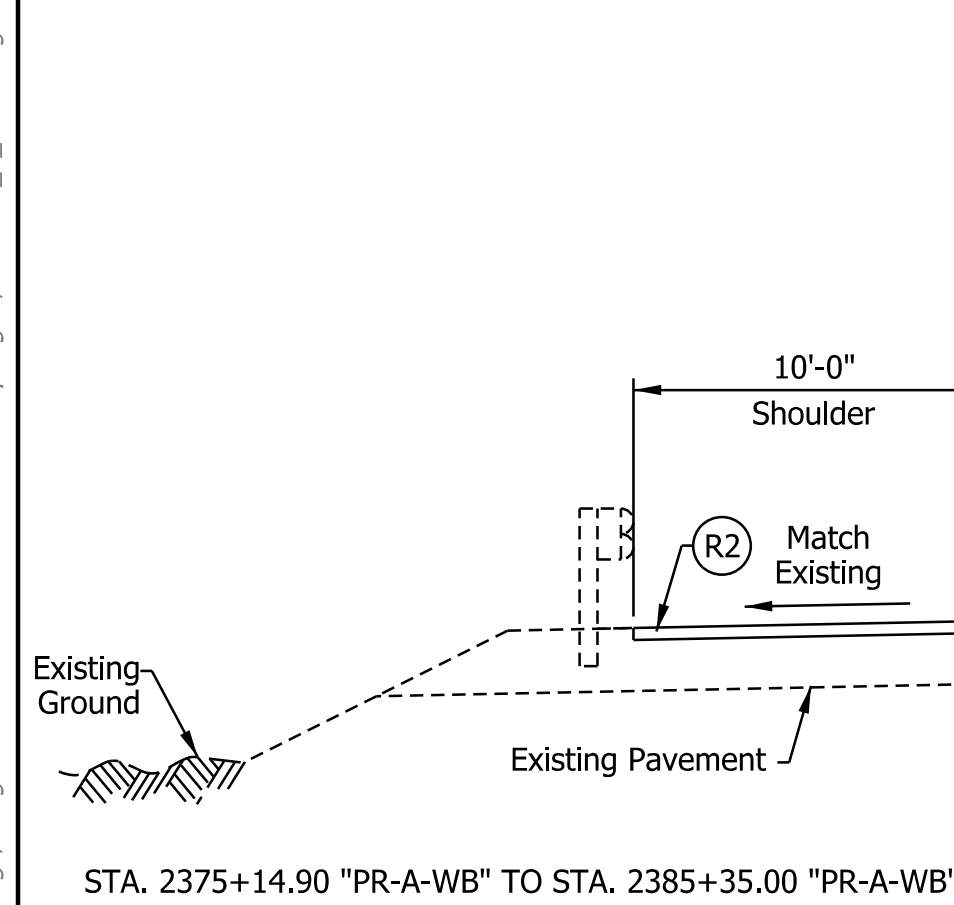

STA. 2372+38.29 "PR-A-WB" TO STA. 2375+14.90 "PR-A-WB"

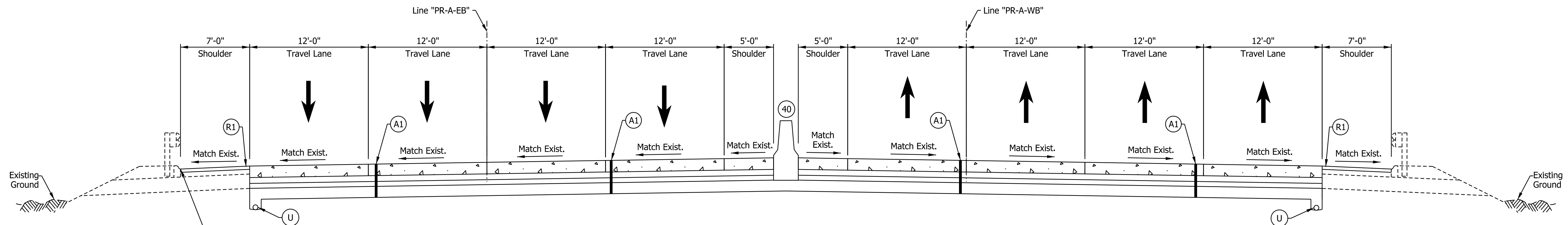

I-64 EB TYPICAL SECTION

STA. 1386+06.25 "PR-A-EB" TO STA. 2388+71.50 "PR-A-EB"

FOR INFORMATION ONLY

I-64 WB TYPICAL SECTION

STA. 2387+57.40 "PR-A-WB" TO STA. 2390+10.10 "PR-A-WB"

khamison 12/16/2022; 11:32:09 AM  
 model: TYP-01 [Sheet]  
 file: p:\i\p\in\hmb\org\PMGreat\_Lakes\Documents\Indianapolis Projects\78704 INDOT-S I-64 ATL 00 CAD-ORD\Sheets\Bridges\No. 20 - I-64 EB and WB over Spring Sl/2200719\_S\_TYP02.dgn

**DRAFT**  
 NOT FOR CONSTRUCTION

RECOMMENDED FOR APPROVAL _____	DESIGN ENGINEER _____	DATE _____
DESIGNED: _____ SGM _____	DRAWN: _____ CGR _____	
CHECKED: _____ ADR _____	CHECKED: _____ ADR _____	

INDIANA  
DEPARTMENT OF TRANSPORTATION

I-64 WESTBOUND MAINLINE  
PROPOSED TYPICAL SECTIONS

HORIZONTAL SCALE	BRIDGE FILE
3/16" = 1'-0"	164-123-04689 C
VERTICAL SCALE	DESIGNATION
AS NOTED	2200719
SURVEY BOOK	SHEETS TYP-02
ELECTRONIC	4 of 13
CONTRACT	PROJECT
R-42570	1900162

khamison  
 12/16/2022; 11:33:24 AM  
 model: TYP-01 [Sheet]  
 file: p:\i\p\i\hmb\org\PM\Great\_Lakes\Documents\Indianapolis Projects\78704 INDOT-S I-64 ATL100 CAD-ORD\Sheets\Bridge\No. 20 - I-64 EB and WB over Spring St\2200719\_S\_P01.dgn

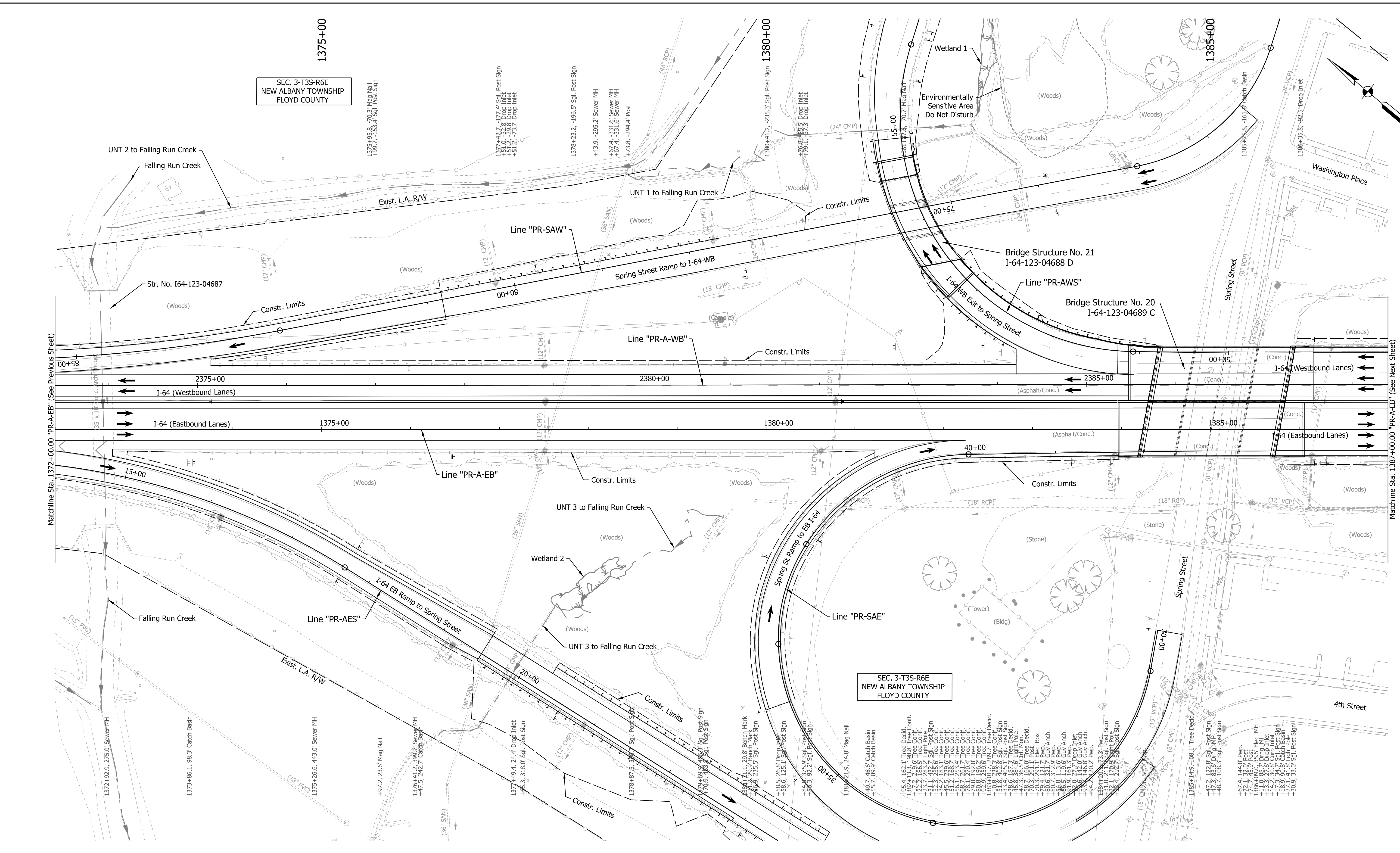

**Note:**  
 For Geometric information see Geometric Layout Sheets  
 GEO-01 to GEO-13.

FOR INFORMATION ONLY

**DRAFT**  
 NOT FOR CONSTRUCTION

RECOMMENDED FOR APPROVAL	DESIGN ENGINEER	DATE
DESIGNED: SGM	DRAWN: RJS	
CHECKED: KRC	CHECKED: KRC	

INDIANA DEPARTMENT OF TRANSPORTATION	
PLAN SHEET	
LINE "PR-A-EB" - STA. 1372+00 TO STA. 1387+00 LINE "PR-A-WB" - STA. 2372+00 TO STA. 2387+00	

HORIZONTAL SCALE	BRIDGE FILE	
1" = 50'	164-123-04689 C	
VERTICAL SCALE	DESIGNATION	
AS NOTED	2200719	
SURVEY BOOK	SHEETS	PP-01
ELECTRONIC	5	of 13
CONTRACT	PROJECT	
R-42570	1900162	

**GENERAL NOTES**

Reinforcing Steel covering shall be 2 1/2" in top and 1" minimum in the bottom of the floor slab, and 2" in all other parts, unless noted.

All exposed faces of concrete bridge and transition railings to be sealed in accordance with Article 702.21 of the Specifications. (Estimated Quantity = 4,260 Sft.)

Where new work is to be fitted to the old work, the Contractor shall check and verify all dimensions, elevations and conditions in the field and report any errors or discrepancies to the Engineer and assume responsibility for their correctness and the fit of the new construction to the existing structure.

Data shown for existing bridge and subsequent geometry for proposed structure taken from original structure plans.

Original and Rehabilitation Plans for existing structure are on file in the Research and Documents Section at the Indiana Department of Transportation, as Bridge File No. I-64-124-4988, I-64-124-4988A, I-64-124-4988B and are available upon request.

**DESIGN DATA**

**LIVE LOAD**

The structure originally designed for H20-S16-44 (Modified) loading in accordance with AASHTO Standard Specifications for Highway Bridges, 1957 Edition. Bridge deck was replaced in 1999 in accordance with Indiana Department of Highway Standard Specifications dated 1988.

**DEAD LOAD**

Originally designed for actual weight plus 35 psf for future wearing surface and 15 psf for permanent metal deck forms.

**DESIGN STRESSES**

CONCRETE:  
CLASS "C": f<sub>c</sub> = 4,000  
REINFORCING STEEL:  
GRADE 60: F<sub>y</sub> = 60,000 PSI

**BRIDGE DECK OVERLAY**

1 3/4" Latex-Modified or Silica Fume Overlay (see Special Provisions for details)

**MATERIAL NOTES**

Concrete used for patching to be in accordance with INDOT Standard Specifications 710.

**NOTES**

- For Typical Bridge Sections, see Dwg. No. PLN-02.
- MGS Guardrail Transition and Terminal Joint pay items included with roadway plans - see Des. No. 1900162.

**LEGEND**

- |  |   |
|--|---|
| <ol style="list-style-type: none"> <li>1/4" Bridge Deck Remove Exist. Conc. Surface; Use Hydrodemolition to remove unsound concrete (Total Bridge Deck Remove Exist. Conc. Surface = 1,926 Sys) Construct 1 3/4" Bridge Deck Overlay (Contractor option of LMC or Microsilica) (Total Bridge Deck Overlay = 2,060 Sys) Perform Longitudinal Grooving on Deck</li> <li>Remove existing Reinf. Conc. Bridge Approach and replace with proposed Reinf. Conc. Bridge Approach (see details)</li> <li>Install new Concrete Bridge Railing Transition, TFC Mod. (1 each) (Total Concrete Bridge Railing Transition, TFC = 4 each)</li> <li>Install new Concrete Median Barrier, Mod. (34 Lft) (Connect to Exist. Conc. Median Barrier) (Total Concrete Median Barrier, Mod. = 68 Lft)</li> </ol> | <ol style="list-style-type: none"> <li>Install new Railing, Concrete FC Mod. (4.5 lft) (Connect to Exist. Railing, Concrete FC) (Total Railing, Concrete FC = 36 lft)</li> <li>Remove exist. portion of mudwall, deck, and concrete bridge rail from back of mudwall extending into deck 4'-0" and convert existing end bents to semi-integral.</li> <li>Remove 6' of Exist. Conc. Slopewall and replace with Slopewall, Concrete, 4" (Total Slopewall, Concrete, 4" = 95 Sys)</li> <li>Inspection Holes to assess condition of existing slopewalls (Total Inspection Holes = 8 each)</li> <li>Surface Seal Exist. Concrete Bridge Rail and install Barrier Delineators</li> <li>Patch delaminated areas of substructure (Est. Qty. = 50 sft)</li> <li>Install Integral Concrete Curb (Total Curb, Integral Concrete = 42 lft)</li> </ol> |
|--|---|

**NOTE TO REVIEWER**

- Additional FC Railing and TFC Transition Formliner details will be provided at STG 3 submittal.
- Additional Railing Concrete FC Mod. width details to be provided at STG 3 submittal.

**CONTINUOUS STEEL BEAM BRIDGE**  
**3 SPANS: 41'-0", 70'-6", 41'-0"**  
**59'-10 1/2" CLEAR ROADWAY (EASTBOUND)**  
**59'-10 1/2" CLEAR ROADWAY (WESTBOUND)**  
**SKEW: 10°34'30" RT.**  
**I-64 EB/WB OVER SPRING STREET**  
**FLOYD COUNTY**

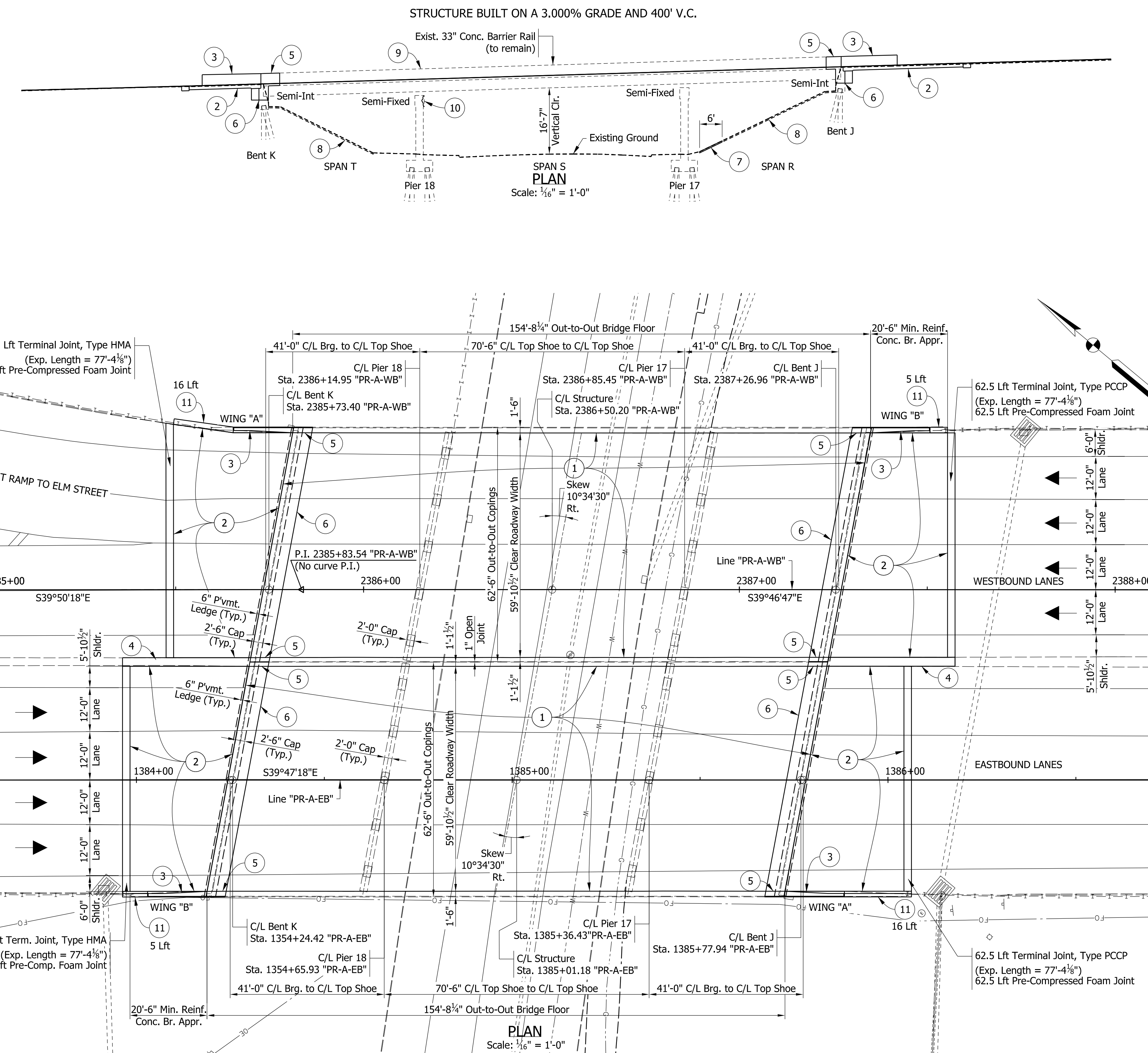

**DRAFT**  
NOT FOR CONSTRUCTION

RECOMMENDED FOR APPROVAL _____	DESIGN ENGINEER _____	DATE _____
DESIGNED: KCH	DRAWN: KCH	
CHECKED: RK	CHECKED: RK	

INDIANA DEPARTMENT OF TRANSPORTATION  
**GENERAL PLAN**

HORIZONTAL SCALE	BRIDGE FILE
AS NOTED	164-123-04689 C
VERTICAL SCALE	DESIGNATION
AS NOTED	2200719
SURVEY BOOK	SHEETS
ELECTRONIC	8 of 13
CONTRACT	PROJECT
R-42570	1900162

khamison 12/16/2022; 1:32:01 PM  
 model: PLN-01 [Sheet]  
 file: p:\i\p\i\lmb\org\PMGreat\_Lakes\Documents\Indianapolis Projects\78704 INDOT-S I-64 ATL100 CAD-ORD\Sheets\Bridges\Bridges\No. 20 - I-64 EB and WB over Spring St\2200719\_S\_PLN01.dgn

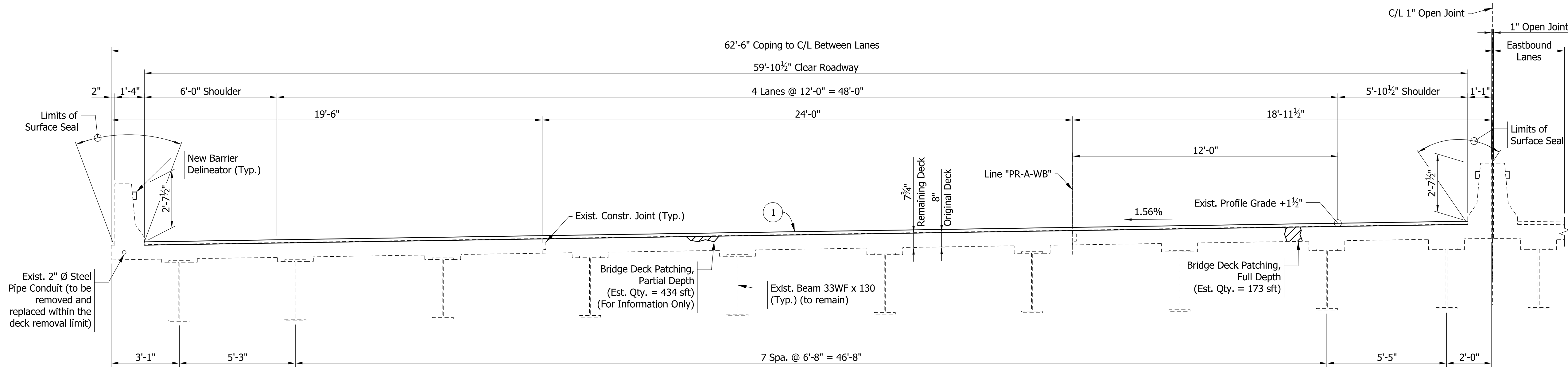

TYPICAL BRIDGE SECTION - WESTBOUND LANES

Scale: 1/16" = 1'-0"

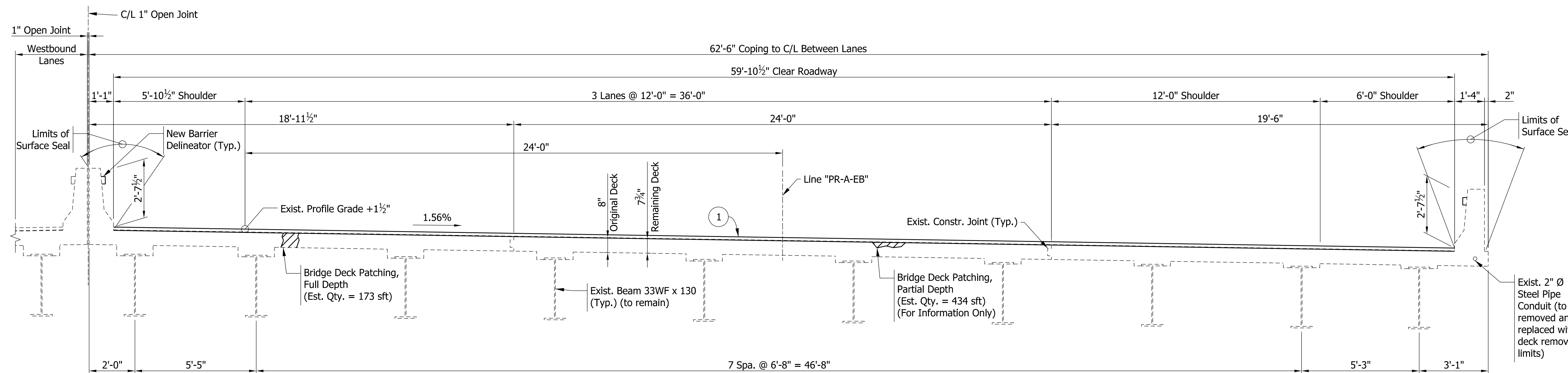

TYPICAL BRIDGE SECTION - EASTBOUND LANES

Scale: 1/16" = 1'-0"

LEGEND

- 1 1/4" Bridge Deck Remove Exist. Conc. Surface; Use Hydrodemolition to remove unsound concrete (Total Bridge Deck Remove Exist. Conc. Surface = 1,926 Sys) Construct 1 3/4" Bridge Deck Overlay (Contractor option of LMC or Microsilica) (Total Bridge Deck Overlay = 2,060 Sys) Perform Longitudinal Grooving on Deck

NOTES

- 1. For Bridge Plan and Elevation, see Dwg. No. PLN-01.

CONTINUOUS STEEL BEAM BRIDGE  
 3 SPANS: 41'-0", 70'-6", 41'-0"  
 59'-10 1/2" CLEAR ROADWAY (EASTBOUND)  
 59'-10 1/2" CLEAR ROADWAY (WESTBOUND)  
 SKEW: 10°34'30" RT.  
 I-64 EB/WB OVER SPRING STREET  
 FLOYD COUNTY

DRAFT  
NOT FOR CONSTRUCTION

RECOMMENDED FOR APPROVAL	DESIGN ENGINEER	DATE
DESIGNED: KCH	DRAWN: KCH	
CHECKED: RK	CHECKED: RK	

INDIANA DEPARTMENT OF TRANSPORTATION	
GENERAL PLAN	

HORIZONTAL SCALE	BRIDGE FILE
AS NOTED	164-123-04689 C
VERTICAL SCALE	DESIGNATION
AS NOTED	2200719
SURVEY BOOK	SHEETS
ELECTRONIC	9 of 13
CONTRACT	PROJECT
R-42570	1900162

khamison 12/16/2022; 1:32:03 PM model: PLN-02 file: p:\i\p\in\hmb\org\p\Great\_Lakes\Documents\Indianapolis Projects\78704 INDOT-S I-64 ATL100 CAD-ORD\Sheets\Bridge\Bridge No. 20 - I-64 EB and WB over Spring St\2200719\_S\_PLN01.dgn



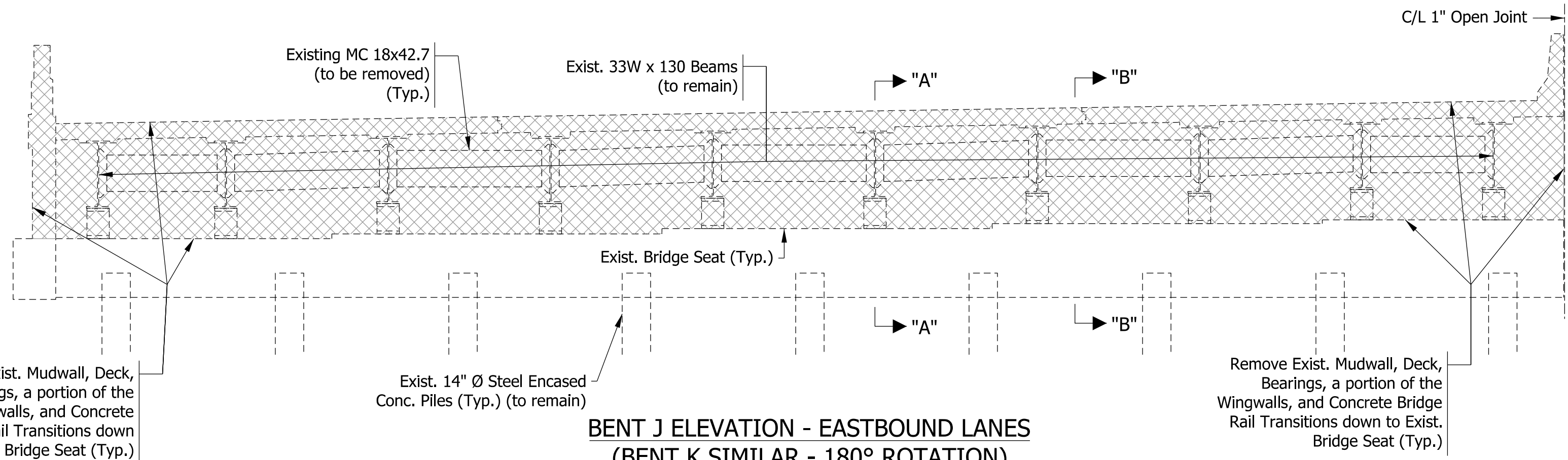

**NOTE TO REVIEWER**  
 Full length of wingwalls do not need to be removed. Further removal details will be included with next submittal.

**BENT J ELEVATION - EASTBOUND LANES**  
 (BENT K SIMILAR - 180° ROTATION)  
 Scale: 3/4" = 1'-0"

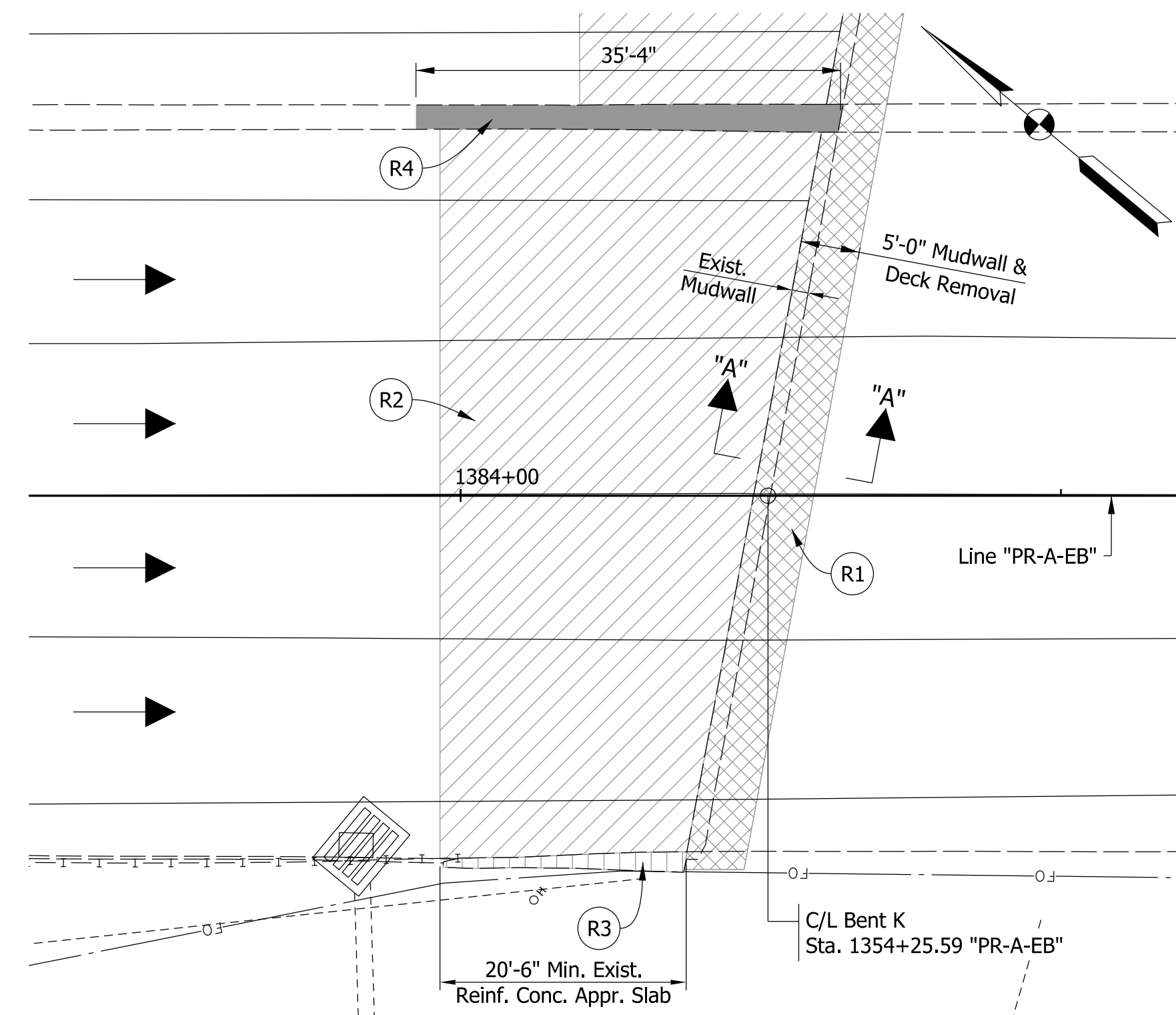

**REMOVAL PLAN - EB STRUCTURE - WEST APPROACH**  
 (EB STRUCTURE - EAST APPROACH AND WB STRUCTURE SIMILAR)  
 Scale: 3/32" = 1'-0"

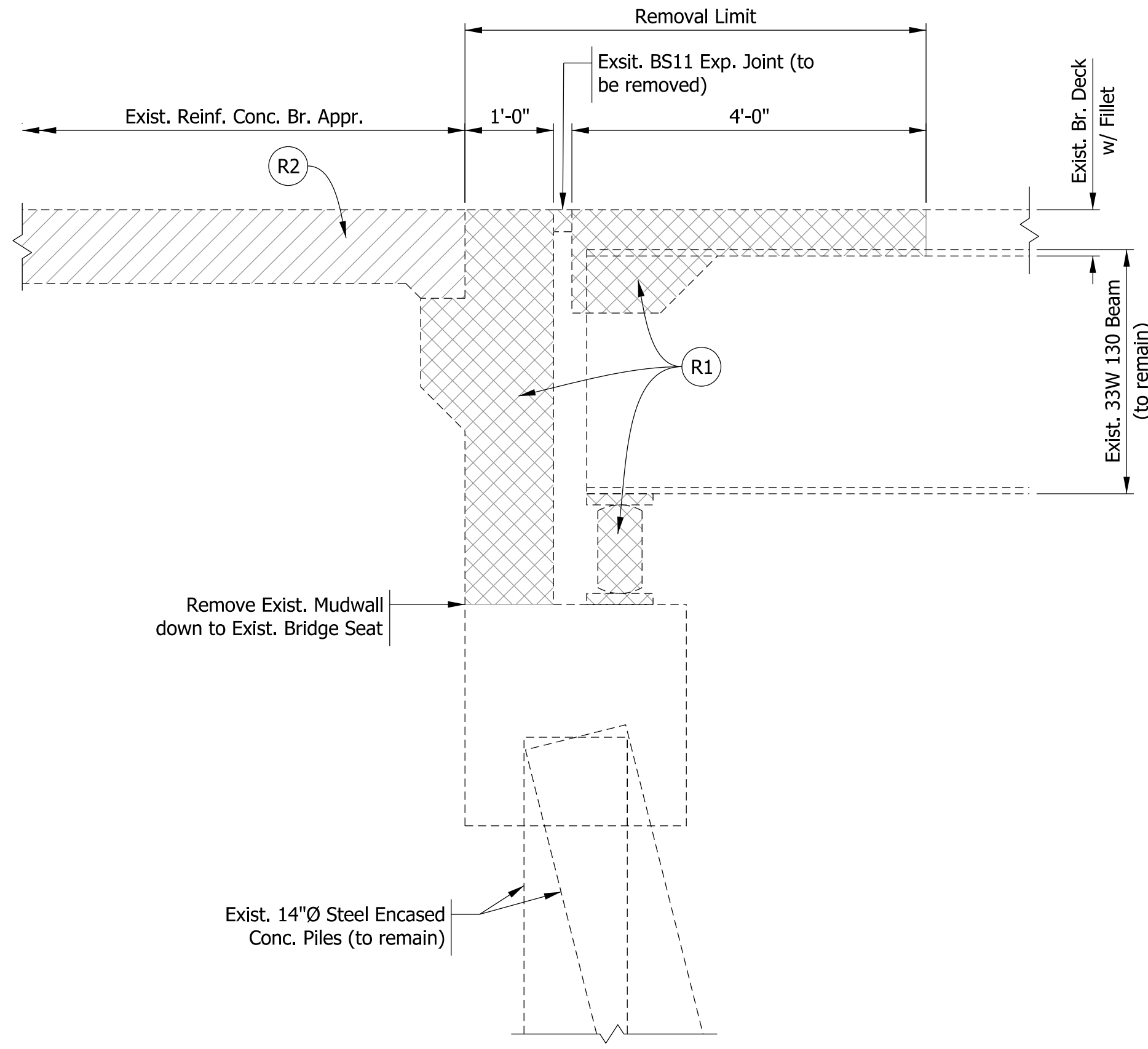

**SECTION "A-A" (THRU BEAM)**

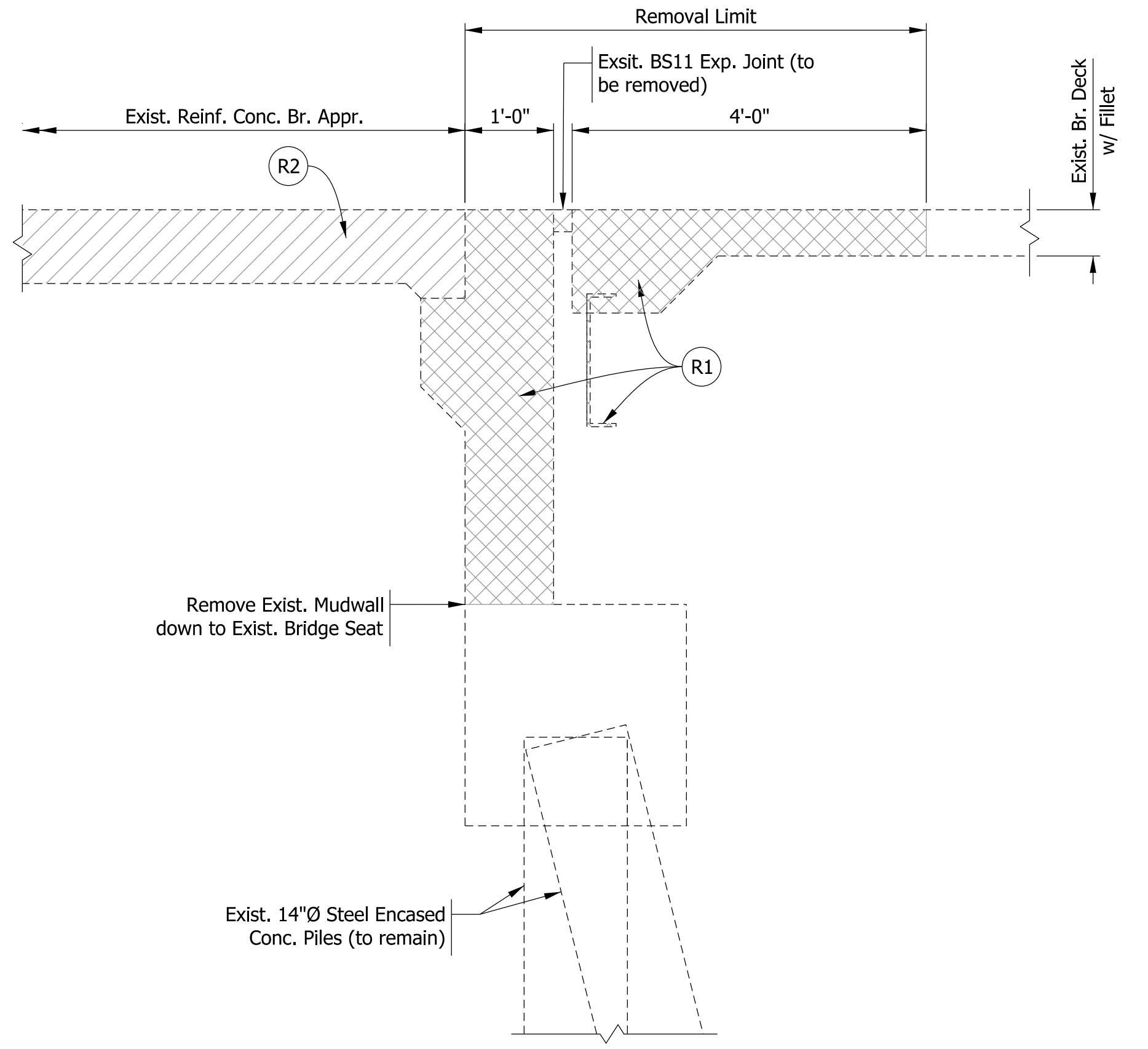

**SECTION "B-B" (BETWEEN BEAMS)**

- LEGEND**
- R1 Remove existing portion of mudwall, deck, cross frames and concrete bridge rail from back of mudwall extending into deck 4'-0"
  - R2 Remove existing Reinforced Concrete Bridge Approach
  - R3 Remove existing Concrete Bridge Railing Transition, TFC
  - R4 Remove existing Concrete Median Barrier

**NOTES**  
 1. Existing 2" Ø Steel Conduit to be removed and replaced within the Deck Removal limits.

**DRAFT**  
 NOT FOR CONSTRUCTION

RECOMMENDED FOR APPROVAL	DESIGN ENGINEER	DATE
DESIGNED: KCH	DRAWN: KCH	
CHECKED: RK	CHECKED: RK	

**INDIANA DEPARTMENT OF TRANSPORTATION**

**REMOVAL DETAILS**

HORIZONTAL SCALE	BRIDGE FILE	
AS NOTED	164-123-04689 C	
VERTICAL SCALE	DESIGNATION	
AS NOTED	2200719	
SURVEY BOOK	SHEETS	REM-01
ELECTRONIC	12 of	13
CONTRACT	PROJECT	
R-42570	1900162	

khamison 12/16/2022; 11:34:20 AM model: REM-01 file: p:\p\in\hmb\org\PM\Great\_Lakes/Documents\Indianapolis Projects\78704 INDOT-S 1-64 ATL 00 CAD-ORD\Sheets\Bridges\Bridg No. 20 - 1-64 EB and WB over Spring Sl/2200719\_S\_REMO1.dgn

PROJECT	DESIGNATION
1900162	2200718
CONTRACT	BRIDGE FILE
R-42570	164-123-04688 D

STRUCTURE INFORMATION				
STRUCTURE	TYPE	SPAN AND SKEW	OVER	STATION
I64-123-04688 D	REINFORCED CONCRETE GIRDER BRIDGE	3 SPANS: 33'-10 1/8", 37'-4", 27'-11 3/8" ON CURVE	I-64 RAMP 123D TO I-64 WBL	☉ STRUCTURE STA. 54+13.81 "PR-AWS"

# INDIANA DEPARTMENT OF TRANSPORTATION

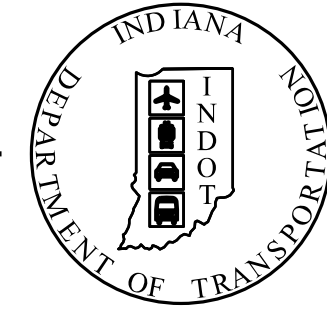

TRAFFIC DATA	I-64 WBL RAMP 123C	I-64 RAMP 123D TO I-64 WBL
A.A.D.T. (2019)	11,870 V.P.D.	6,510 V.P.D.
A.A.D.T. (2046)	14,050 V.P.D.	9,320 V.P.D.
D.H.V (2046)	1,740 V.P.H.	1,270 V.P.H.
DIRECTIONAL DISTRIBUTION	100%	100%
TRUCKS	3%	5%
	1% D.H.V.	2% D.H.V.

DESIGN DATA		
DESIGN SPEED	70 M.P.H.	
PROJECT DESIGN CRITERIA	4R (FREEWAY)	NO IMPROVEMENT
FUNCTIONAL CLASSIFICATION	INTERSTATE	
RURAL/URBAN	URBAN	
TERRAIN	ROLLING	
ACCESS CONTROL	FULL	

## BRIDGE PREVENTIVE MAINTENANCE PLANS FOR SPANS OVER 20 FEET

ROUTE : I-64 WB RAMP AT: RP 123+45

PROJECT NO. 2200718 P.E.  
1900162 R/W  
2200718 CONST.

KIN PROJECT INFORMATION			
DESIGNATION	PROJECT DESCRIPTION		
ROAD			
1900162	Added Travel Lanes on I-64		LEAD DES.
1900366	US 150 and Old Vincennes Road (East)		
2100019	I-64 Lighting US 150 to I-64 / I-265		
BRIDGE			
1800706	Bridge Painting on US 150 EB over I-64	Str. 1	
1800405	Bridge Painting on US 150 WB over I-64	Str. 2	
1700207	Bridge Replacement on I-64 EB over Quarry Road	Str. 3	
2200015	Bridge Replacement on I-64 WB over Quarry Road	Str. 4	
1702617	Bridge Replacement on I-64 WB over I-64 Ramp to I-265 EB	Str. 5A	
2200016	Bridge Replacement on I-64 EB over I-64 Ramp to I-265 EB	Str. 5B	
1800721	Bridge Replacement on I-64 WB over I-265 Ramp to I-64 EB	Str. 6	
2200019	Bridge Replacement on I-265 WB to I-64 EB over I-64 EB to I-265 EB	Str. 7	
2200017	Bridge Replacement on I-64 EB over Captain Frank Road	Str. 8	
2200018	Superstructure Replacement on I-64 WB over Captain Frank Road	Str. 9	
1702614	Bridge Deck Overlay on I-64 EB & WB over Cherry Street	Str. 10	
2000326 / 2000323	Bridge Deck Replacement and Widening on I-265 EB over State Street	Str. 11	
2000324	Bridge Deck Overlay on I-265 WB over State Street	Str. 12	
1700205	I-64 WB over SR62 / SR 64	Str. 14	
1700206	I-64 EB over SR62 / SR 64	Str. 13	
2000144	Bridge Deck Overlay on I-64 EB over Yenowine Lane	Str. 15	
2000145	Bridge Deck Overlay on I-64 WB over Yenowine Lane	Str. 16	
2002072	US 150 EB over Little Indian Creek	Str. 18	
2002073	US 150 WB over Little Indian Creek	Str. 19	
2200719	I-64 EB & WB over SR 62 / Spring Street	Str. 20	
2200718	I-64 WB Off-Ramp to Spring over I-64 WB On-Ramp from Spring	Str. 21	
DRAINAGE			
TBD	US 150 Twin Arch Pipe Liner	Str. 17	
TBD	Valley View Creek (6 Small Structure and 7 Small Pipe Replacements)		
TBD	Valley View Creek CMP Liner		
TBD	UNT to Little Indian Creek CMP Liner		
TBD	Hill Brook CMP Liner		
TBD	Small Pipes CMP Liners (2)		

BRIDGE DECK OVERLAY ON I-64 WB RAMP OVER I-64 RAMP 123D TO I-64 WB LOCATED 0.28 MILES WEST OF SR 111 IN SECTION 3, T-3-S, R-6-E, NEW ALBANY TOWNSHIP, FLOYD COUNTY, INDIANA

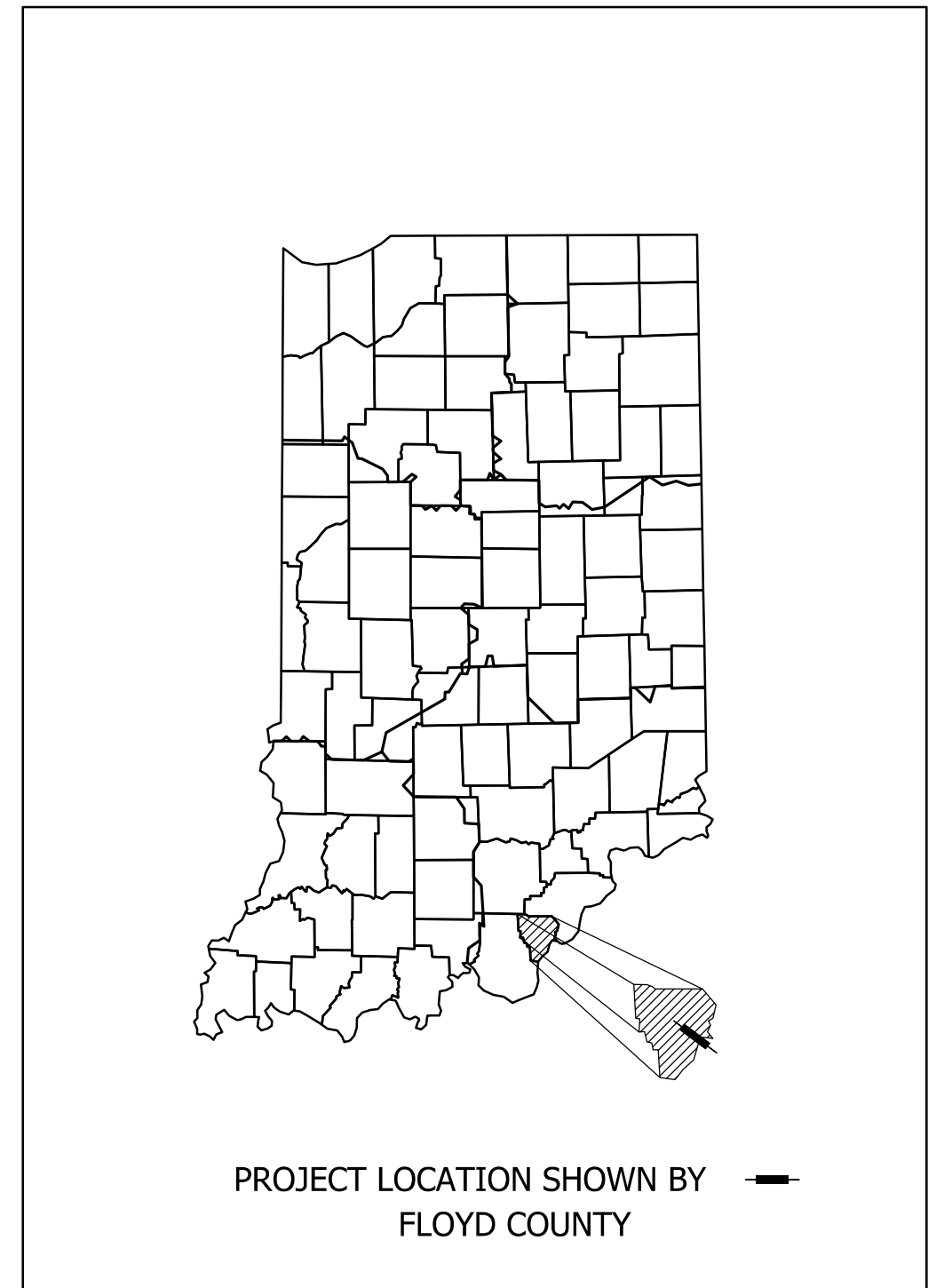
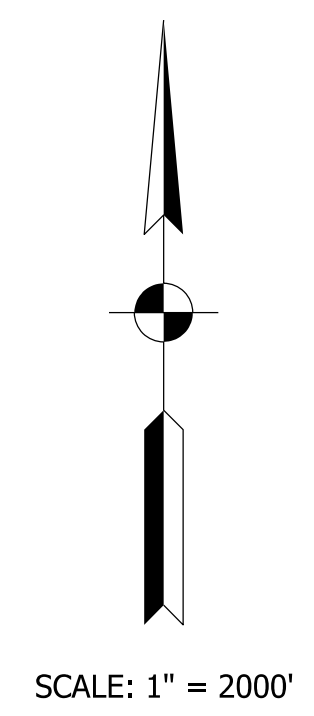
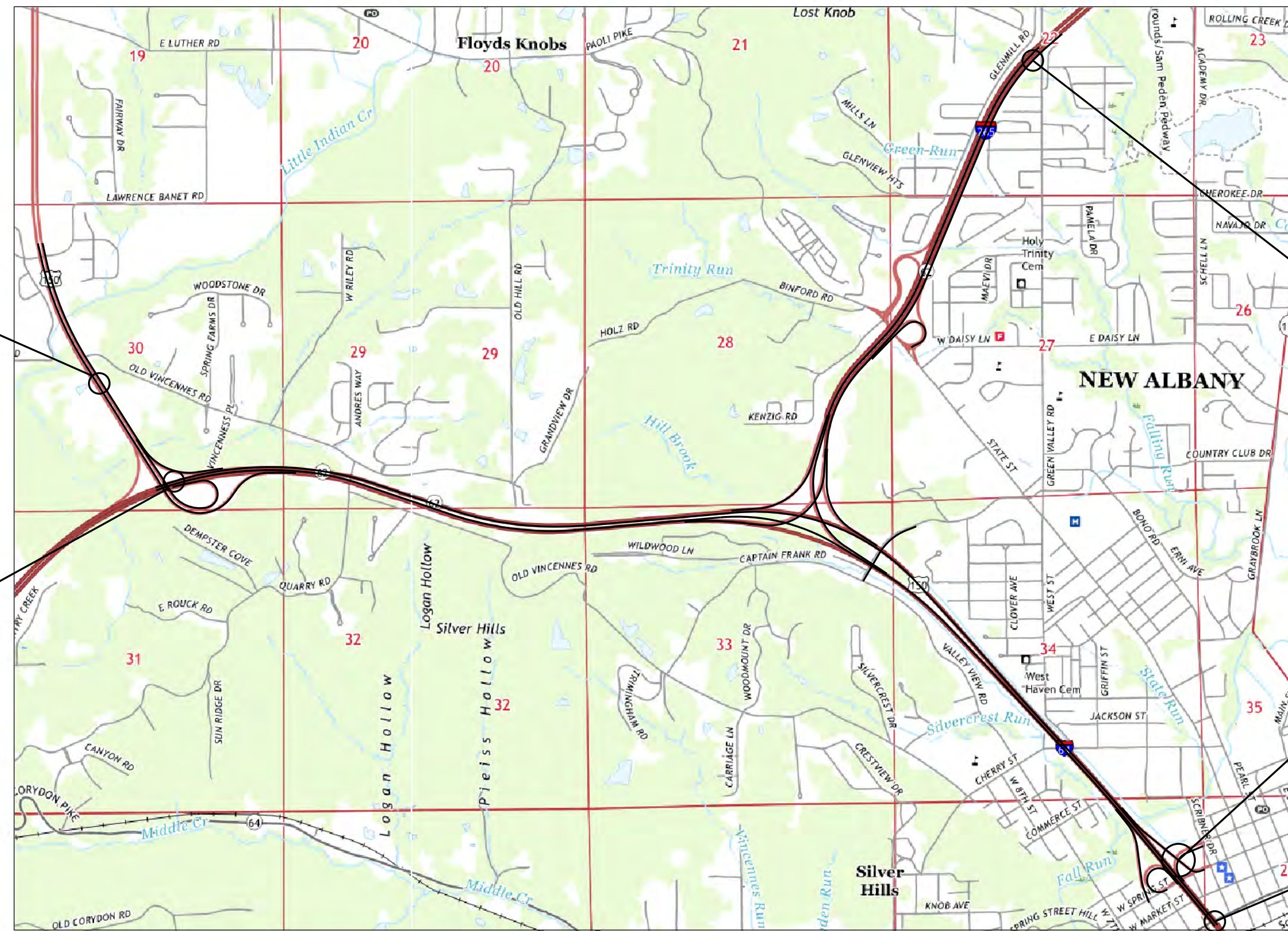

LATITUDE: 38°17'07" N	LONGITUDE: 85°49'42" W
BRIDGE LENGTH: _____	0.020 MI.
ROADWAY LENGTH: _____	* MI.
TOTAL LENGTH: _____	* MI.
MAX. GRADE: _____	1.850 %
* SEE DES NO. 1900162	
12-DIGIT HYDROLOGIC UNIT CODE: 051401010904	

**NOTE TO REVIEWER**  
The list of KIN'd projects is tentative and subject to change at INDOT Seymour District's direction. This list represents the current understanding of the contract package.

**STAGE 2 PLANS**



**DRAFT**  
NOT FOR CONSTRUCTION

PLANS PREPARED BY: SJCA, INC	(317) 566-0629
CERTIFIED BY: _____	PHONE NUMBER
RECOMMENDED FOR LETTING: _____	DATE
INDIANA DEPARTMENT OF TRANSPORTATION	
DATE	

INDIANA DEPARTMENT OF TRANSPORTATION  
STANDARD SPECIFICATIONS DATED 2022  
TO BE USED WITH THESE PLANS

BRIDGE FILE		
164-123-04688 D		
DESIGNATION		
2200718		
SURVEY BOOK	SHEETS	TTL-01
ELECTRONIC	1 of	8
CONTRACT	PROJECT	
R-42570	1900162	

kharison 12/5/2022 4:42:04 PM model: TTL-01 [Sheet] file: p:\i\p\i\h\mb\org\PM\Great\_Lakes\Documents\Indianapolis Projects\78704 INDOT-S I-64 ATL 00 CAD-ORD\Sheets\Bridges\Bridges No. 21 - I-64 WB Exit over I-64 WB Entrance\2200718\_S\_TTL01.dgn

khamison 12/5/2022; 4:42:19 PM model: TYP-01 [Sheet] file: p:\i\p\in\hmb\org\PMGreat\_Lakes\Documents\Indianapolis\Projects\78704 INDOT-S I-64 ATL 00 CAD-ORD\Sheets\Bridges\Bridg No. 21 - I-64 WB Exit over I-64 WB Entrance\220718\_S\_TYP01.dgn

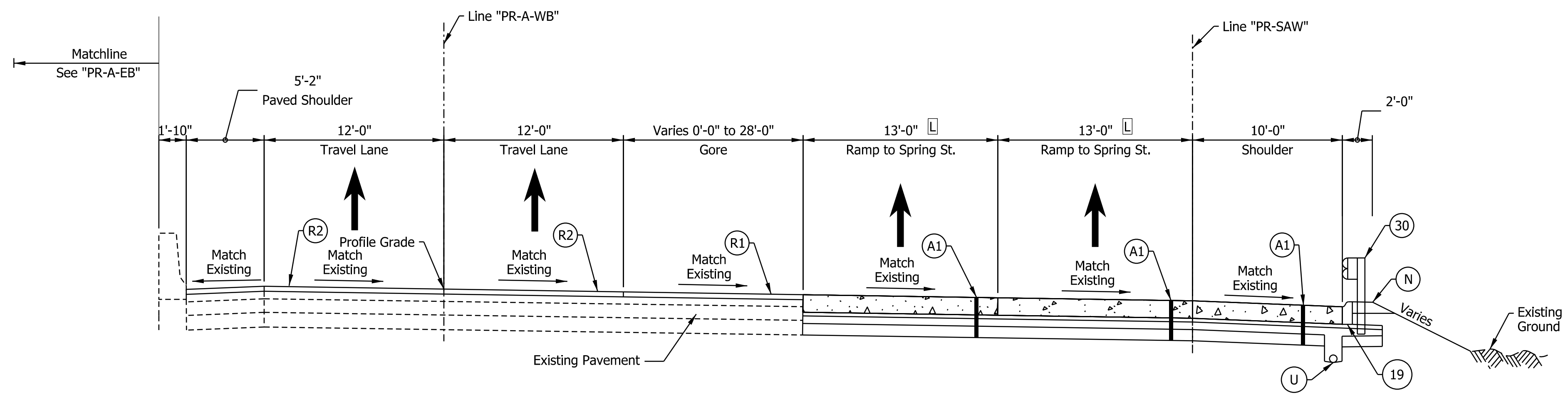

**I-64 WB TO SPRING ST. AT THE GORE TYPICAL SECTION**  
 STA. 51+25.24 "PR-AWS" TO STA. 52+29.77 "PR-AWS"

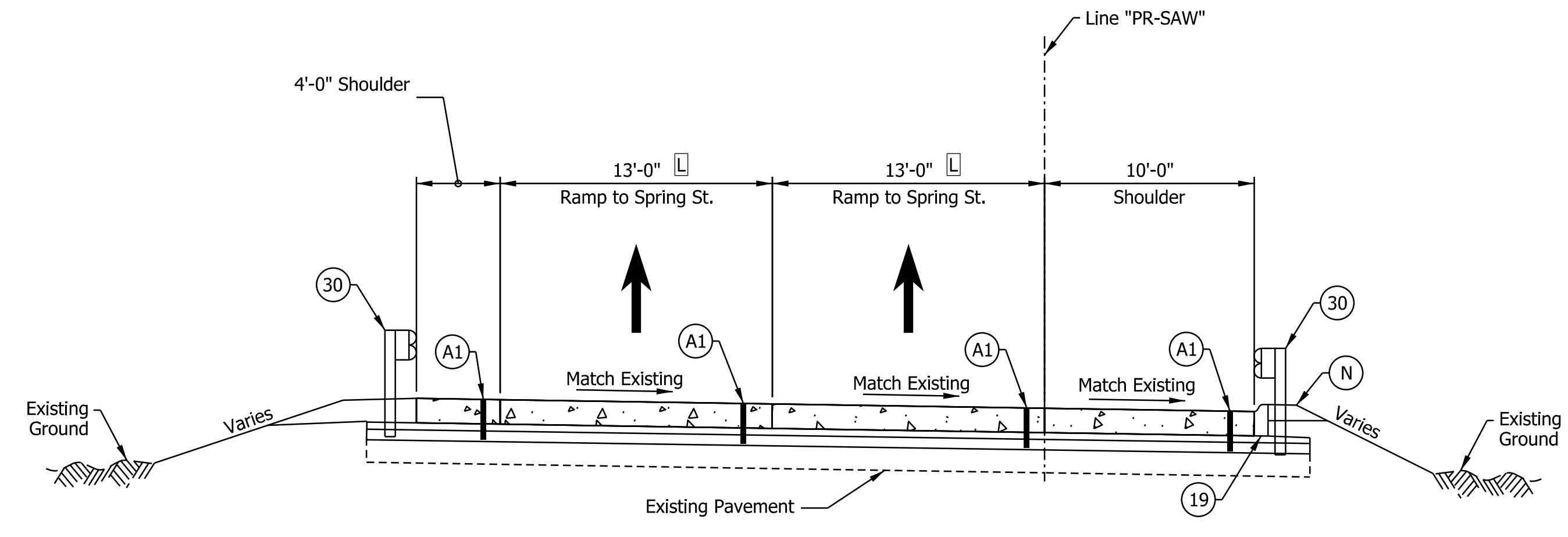

**I-64 WB TO SPRING ST. TYPICAL SECTION**  
 STA. 52+29.77 "PR-AWS" TO STA. 55+70.80 "PR-AWS"  
 Bridge Paving Exception Sta. 53+45.00 to Sta. 54+50.00

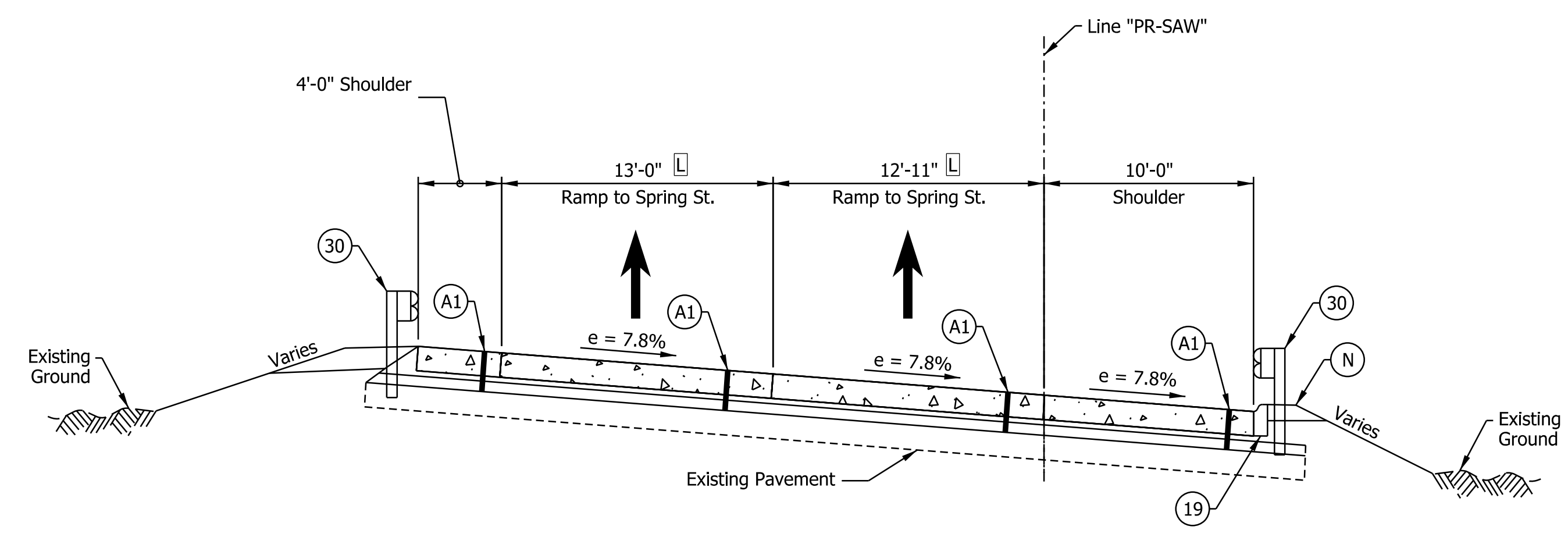

**I-64 WB TO SPRING ST. SUPERELEVATED TYPICAL SECTION**  
 STA. 52+98.00 "PR-AWS" TO STA. 54+95.45 "PR-AWS"

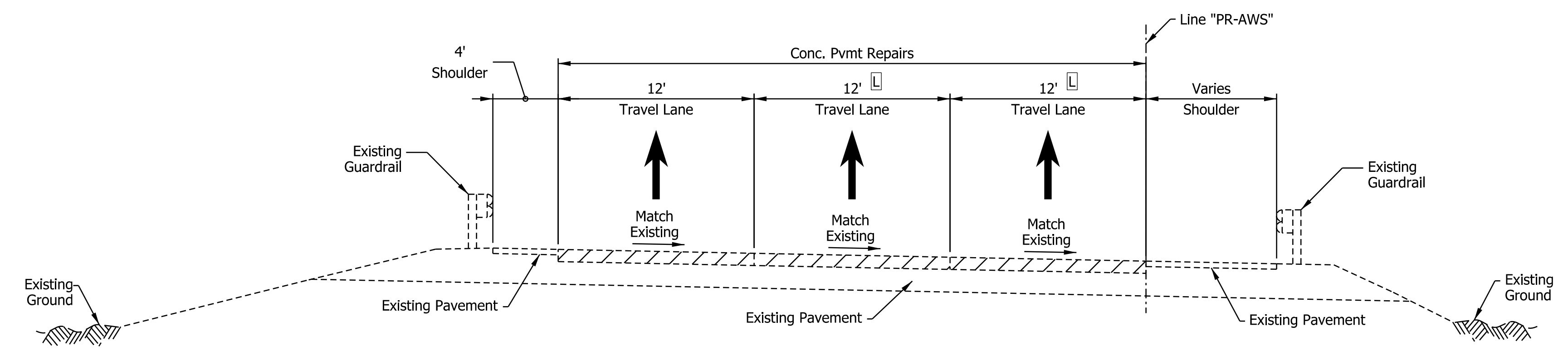

**I-64 WB TO SPRING ST. RAMP TYPICAL SECTION**  
 STA. 54+95.45 "PR-AWS" TO STA. 58+58.00 "PR-AWS"

- Notes:**
- See Sheet LGD-01 for construction legend
  - See Sheet TS-43 for Safety Edge Details
  - A** Lane width varies 16'-0" from STA. 17+67.97 "PR-AES" to 24'-0" from STA. 19+50.00 "PR-AES"
  - B** Replace from STA. 20+30.00 "PR-AES" to STA. 23+90.00 "PR-AES"
  - C** Replace from STA. 19+50.00 "PR-AES" to STA. 25+70.00 "PR-AES"
  - D** Equals 16'-0" from STA. 31+36.00 "PR-SAE" to STA. 32+42.00 "PR-SAE"  
Varies from 16'-0" at STA. 32+42.00 "PR-SAE" to 0'-0" at STA. 36+00.00 "PR-SAE"
  - E** Equals 2'-0" from STA. 31+36.00 "PR-SAE" to STA. 32+26.00 "PR-SAE"  
Equals 0'-0" at STA. 32+26.00 "PR-SAE"
  - F** Equals 13'-0" from STA. 30+00.00 "PR-SAE" to STA. 32+42.00 "PR-SAE"  
Varies from 13'-0" at STA. 32+42.00 "PR-SAE" to 12'-0" at STA. 36+00.00 "PR-SAE"
  - G** Lane width varies 24'-0" from STA. 36+00.00 "PR-SAE" to 16'-0" from STA. 40+00.00 "PR-SAE"
  - H** Equals 6'-0" from STA. 19+50.00 to STA. 21+11.70 "PR-AES"  
Equals 2'-0" from STA. 21+11.70 to STA. 26+76.00 "PR-AES"
  - I** Replace from STA. 76+68.09 to STA. 80+84.00 "PR-SAW"
  - L** Equals 13'-0" from STA. 51+25.24 "PR-AWS" to STA. 55+12.51 "PR-AWS"  
Varies from 13'-0" at STA. 55+12.51 "PR-AWS" to 12'-0" at STA. 56+12.49 "PR-AWS"
  - M** Replace from STA. 33+13.75 to STA. 33+83.39 "PR-SAE"

FOR INFORMATION ONLY

**DRAFT**  
 NOT FOR CONSTRUCTION

RECOMMENDED FOR APPROVAL _____	DESIGN ENGINEER _____	DATE _____
DESIGNED: _____ JKH _____	DRAWN: _____ JKH _____	
CHECKED: _____ ADR _____	CHECKED: _____ ADR _____	

INDIANA  
 DEPARTMENT OF TRANSPORTATION

**I-64 / SPRING STREET INTERCHANGE RAMP  
 PROPOSED TYPICAL SECTIONS**

HORIZONTAL SCALE	BRIDGE FILE
3/16" = 1'-0"	164-122-04988 D
VERTICAL SCALE	DESIGNATION
N/A	2200718
SURVEY BOOK	SHEETS TYP-01
ELECTRONIC	3 of 8
CONTRACT	PROJECT
R-42570	1900162

khamison  
 12/5/2022; 4:43:30 PM  
 model: TYP-01 [Sheet]  
 file: p:\i\p\in\hmb\org\PM\Great\_Lakes\Documents\Indianapolis Projects\78704 INDOT-S I-64 ATL100 CAD-ORD\Sheets\Bridge\Bridge No. 21 - I-64 WB Exit over I-64 WB Entrance\2200718\_S\_PP01.dgn

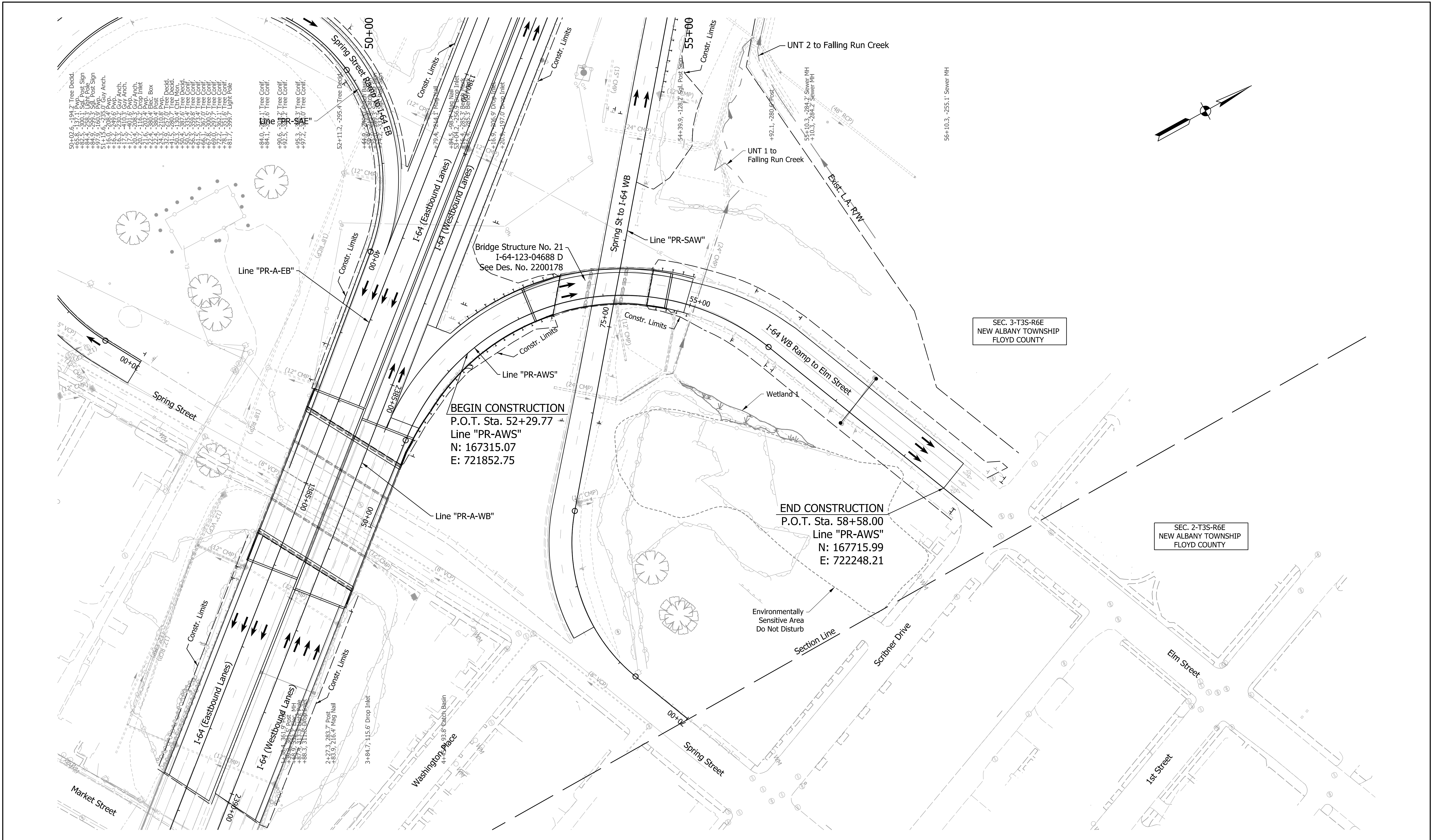

Note:  
 For Geometric information see Geometric Layout Sheets  
 GEO-01 to GEO-13.

FOR INFORMATION ONLY

**DRAFT**  
 NOT FOR CONSTRUCTION

RECOMMENDED FOR APPROVAL	DESIGN ENGINEER	DATE
DESIGNED: MDS	DRAWN: RJS	
CHECKED: KRC	CHECKED: KRC	

INDIANA  
 DEPARTMENT OF TRANSPORTATION  
  
 PLAN SHEET  
 LINE "PR-AWS"  
 STA. 52+29.77 TO STA. 58+58

HORIZONTAL SCALE	BRIDGE FILE
1"=50'	164-122-04988 D
VERTICAL SCALE	DESIGNATION
N/A	2200718
SURVEY BOOK	SHEETS
ELECTRONIC	4 of 8
CONTRACT	PROJECT
R-42570	1900162

STRUCTURE BUILT ON A -1.15% GRADE, 100' VERTICAL CURVE, & A -3.35% GRADE

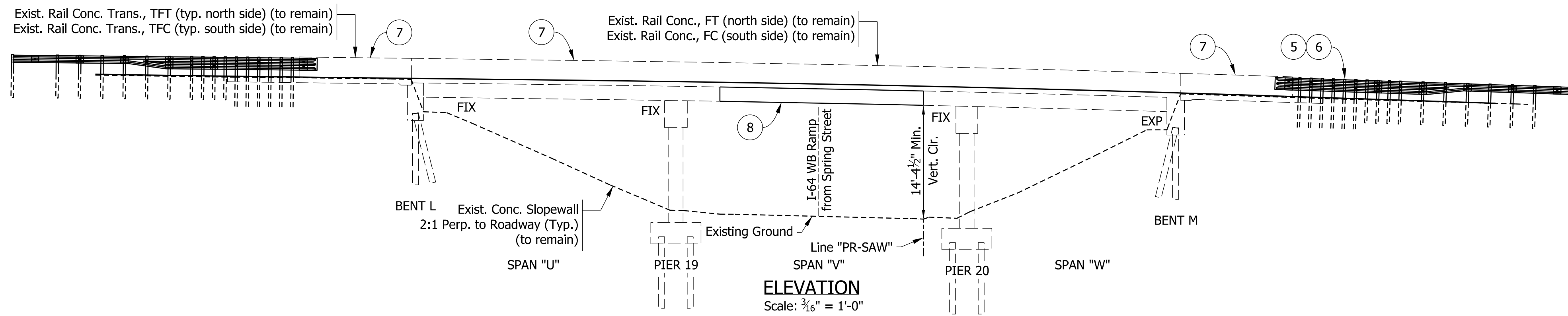

ELEVATION  
Scale: 3/16" = 1'-0"

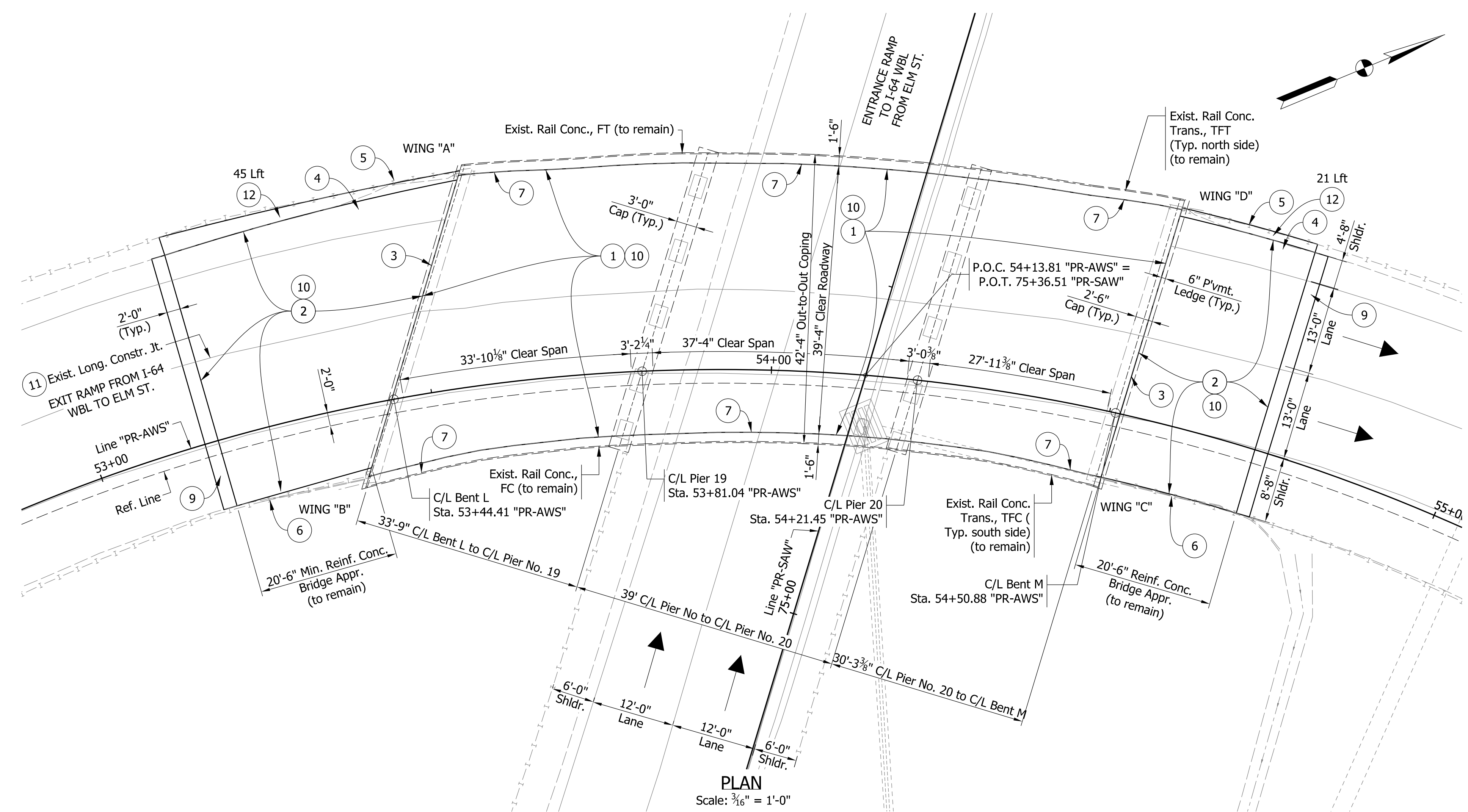

PLAN  
Scale: 3/16" = 1'-0"

GENERAL NOTES

All exposed faces of concrete bridge and transition railings to be sealed in accordance with Article 702.21 of the Specifications. (Estimated Quantity = 4078 Sft.)

Where new work is to be fitted to the old work, the Contractor shall check and verify all dimensions, elevations and conditions in the field and report any errors or discrepancies to the Engineer and assume responsibility for their correctness and the fit of the new construction to the existing structure.

Data shown for existing bridge and subsequent geometry for proposed structure taken from original structure plans.

Original and Rehabilitation Plans for existing structure are on file in the Research and Documents Section at the Indiana Department of Transportation, as Bridge File No. I-64-124-4688, I-64-124-4688A, I-64-124-4688B, I-64-124-4688C and are available upon request.

DESIGN DATA

**LIVE LOAD**  
The structure originally designed for HS20-S16-44 loading in accordance with AASHTO Standard Specifications for Highway Bridges 1957 Edition. The bridge deck was replaced and widened in 1991 in accordance with Indiana Department of Highways Standard Specifications dated 1988.

**DEAD LOAD**  
Originally designed for actual weight plus 35 psf for future wearing surface and 15 psf for permanent metal deck forms.

**BRIDGE DECK OVERLAY**  
1 3/4" Latex-Modified, or Silica Fume Overlay (see Special Provisions for details)

**MATERIAL NOTES**  
Concrete used for patching to be in accordance with INDOT Standard Specifications 710.

**NOTES**  
1. For Typical Bridge Sections, see Dwg. No. PLN-02.  
2. For clarity, the dimensions shown are based off existing plans while the alignments are based of survey data. Discrepancies may exist between the data.  
3. MGS Guardrail Trans., Guardrail End Treatment, Guardrail Remove, and Terminal Joint pay items included with roadway plans - see Des. No. 1900162.

LEGEND

- 1 1/4" Bridge Deck Remove Exist. Conc. Surface; Use Hydrodemolition to remove unsound concrete (Total Bridge Deck Remove Exist. Conc. Surface = 475 Sys)
- 2 1/4" Bridge Deck Remove Exist. Conc. Surface on exist. Reinf. Conc. Br. Appr.; Use Hydrodemolition to remove unsound concrete (Total Bridge Deck Remove Exist. Conc. Surface = 231 Sys)
- 3 Install Overlay Dam at Bridge/Reinf. Conc. Br. Appr. interface
- 4 Fill voids under Reinf. Conc. Br. Appr. w/ Flowable Backfill (Flowable Backfill = 19 Cys per side) (Total Flowable Backfill = 38 Cys)
- 5 Install MGS Guardrail Transition w/ Curb (1 each) & Guardrail End Treatment, OS (31" height) (1 each)
- 6 Install MGS Guardrail Transition w/ Curb (1 each) & MGS Guardrail Height Transition (1 each) (Connect to existing guardrail)
- 7 Surface Seal existing Railing, Conc. and Railing Conc. Trans. and Install Barrier Delineators
- 8 Patch spalled areas and Fiber Wrap existing Concrete Girder No. 5 from west end
- 9 Install Polymer Modified Asphalt Terminal Joint
- 10 Crack Repair using Epoxy Injection
- 11 Install Type 1-A Construction Joint in the overlay areas to perpetuate existing longitudinal construction joint in the exist. Reinf. Conc. Bridge Approach and the exist. Bridge Deck
- 12 Install retrofit integral concrete curb to adjacent to exist. Reinf. Conc. Bridge Approach. (Total Integral Conc. Curb = 66 Lft)

REINFORCED CONCRETE GIRDER BRIDGE  
3 SPANS: 33'-10 1/8", 37'-4", 27'-11 3/8"  
39'-4" CLEAR ROADWAY  
ON CURVE  
I-64 WBL RAMP 123C OVER I-64 RAMP 123D TO I-64 WBL  
FLOYD COUNTY

khamison 12/5/2022; 4:46:19 PM model: PLN-01 [Sheet] file: p:\i\p\in\hmb\org\PM\GreatLakes\Documents\Indianapolis Projects\78704 INDOT-S I-64 ATL 00 CAD-ORD\Sheets\Bridge\Bridg No. 21 - I-64 WBL Exit over I-64 WBL Entrance\2200718\_S\_PLN01.dgn

**DRAFT**  
NOT FOR CONSTRUCTION

RECOMMENDED FOR APPROVAL	DESIGN ENGINEER	DATE
DESIGNED: KCH	DRAWN: KCH	
CHECKED: RK	CHECKED: RK	

INDIANA DEPARTMENT OF TRANSPORTATION	
GENERAL PLAN	

HORIZONTAL SCALE	BRIDGE FILE
AS NOTED	164-123-04688 D
VERTICAL SCALE	DESIGNATION
AS NOTED	2200718
SURVEY BOOK	SHEETS
ELECTRONIC	6 of 8
CONTRACT	PROJECT
R-42570	1900162

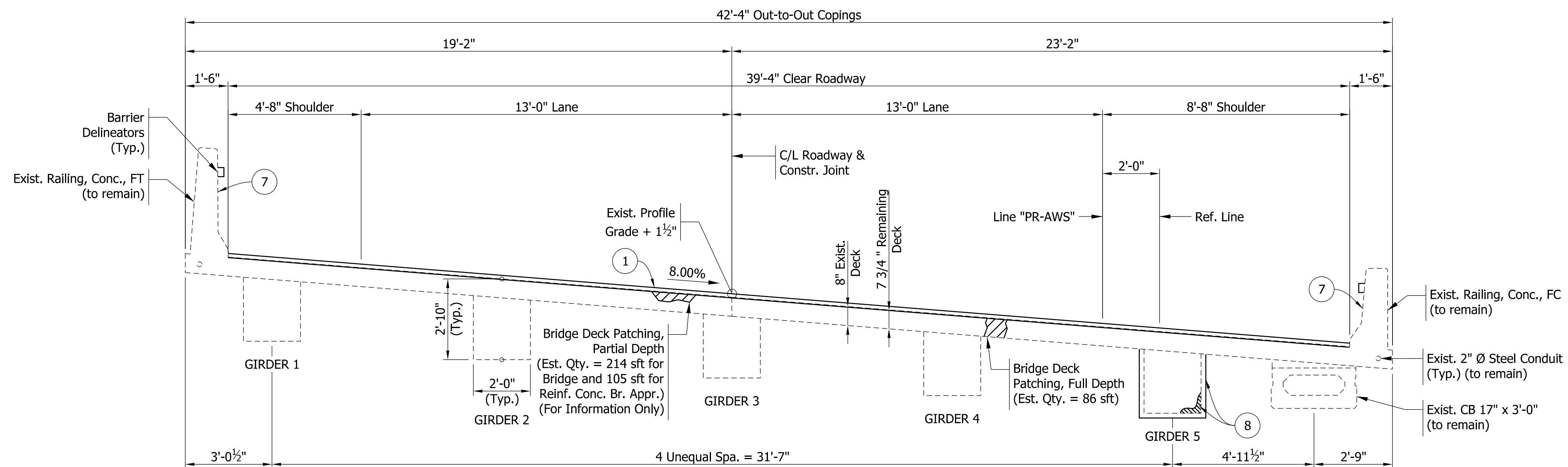

**TYPICAL BRIDGE SECTION**

Scale: 1/16" = 1'-0"

**LEGEND**

- ① 1/4" Bridge Deck Remove Exist. Conc. Surface; Use Hydrodemolition to remove unsound concrete (Total Bridge Deck Remove Exist. Conc. Surface = 475 Sys) Construct 1 3/4" Bridge Deck Overlay (Contractor option of LMC or Microsilica) (Total Bridge Deck Overlay = 475 Sys) Perform Longitudinal Grooving on Deck
- ② 1/4" Bridge Deck Remove Exist. Conc. Surface on exist. Reinf. Conc. Br. Appr.; Use Hydrodemolition to remove unsound concrete (Total Bridge Deck Remove Exist. Conc. Surface = 231 Sys) Construct 1 3/4" Bridge Deck Overlay (Contractor Option of LMC or Microsilica) (Total Bridge Deck Overlay = 231 Sys) Perform Longitudinal Grooving on Reinf. Conc. Br. Appr.
- ③ Install Overlay Dam at Bridge/Reinf. Conc. Br. Appr. interface
- ④ Fill voids under Reinf. Conc. Br. Appr. w/ Flowable Backfill (Flowable Backfill = 19 Cys per side) (Total Flowable Backfill = 38 Cys)
- ⑤ Install MGS Guardrail Transition w/ Curb (1 each) & Guardrail End Treatment, OS (31" height) (1 each)
- ⑥ Install MGS Guardrail Transition w/ Curb (1 each) & MGS Guardrail Height Transition (1 each) (Connect to existing guardrail)
- ⑦ Surface Seal existing Railing, Conc. and Railing Conc. Trans. and Install Barrier Delineators
- ⑧ Patch spalled areas and Fiber Wrap existing Concrete Girder No. 5 from edge of pavement to edge of pavement of Spring St. to I-64 WB ramp lanes
- ⑨ Install Polymer Modified Asphalt Terminal Joint
- ⑩ Crack Repair using Epoxy Injection

**NOTES**

1. For Bridge Plan and Elevation, see Dwg. No. PLN-01.

**REINFORCED CONCRETE GIRDER BRIDGE**  
**3 SPANS: 33'-10 1/8", 37'-4", 27'-11 3/8"**  
**39'-4" CLEAR ROADWAY**  
**ON CURVE**  
**I-64 WBL RAMP 123C OVER I-64 RAMP 123D TO I-64 WB**  
**FLOYD COUNTY**

khamison  
 12/5/2022; 4:41:11 PM  
 model: PLN-02  
 file: p:\i\p\in\hmb\org\PHGreat\_Lakes\Documents\Indianapolis Projects\78704 INDOT-S I-64 ATL 00 CAD-ORD\Sheets\Bridge\Bridge No. 21 - I-64 WB Exit over I-64 WB Entrance\200718\_S\_PLN01.dgn

**DRAFT**  
NOT FOR CONSTRUCTION

RECOMMENDED FOR APPROVAL _____	DESIGN ENGINEER _____	DATE _____
DESIGNED: _____ KCH _____	DRAWN: _____ KCH _____	
CHECKED: _____ RK _____	CHECKED: _____ RK _____	

INDIANA  
DEPARTMENT OF TRANSPORTATION

GENERAL PLAN

HORIZONTAL SCALE	BRIDGE FILE	
AS NOTED	164-123-04688 D	
VERTICAL SCALE	DESIGNATION	
AS NOTED	2200718	
SURVEY BOOK	SHEETS	PLN-02
ELECTRONIC	7	of 8
CONTRACT	PROJECT	
R-42570	1900162	

# Detours

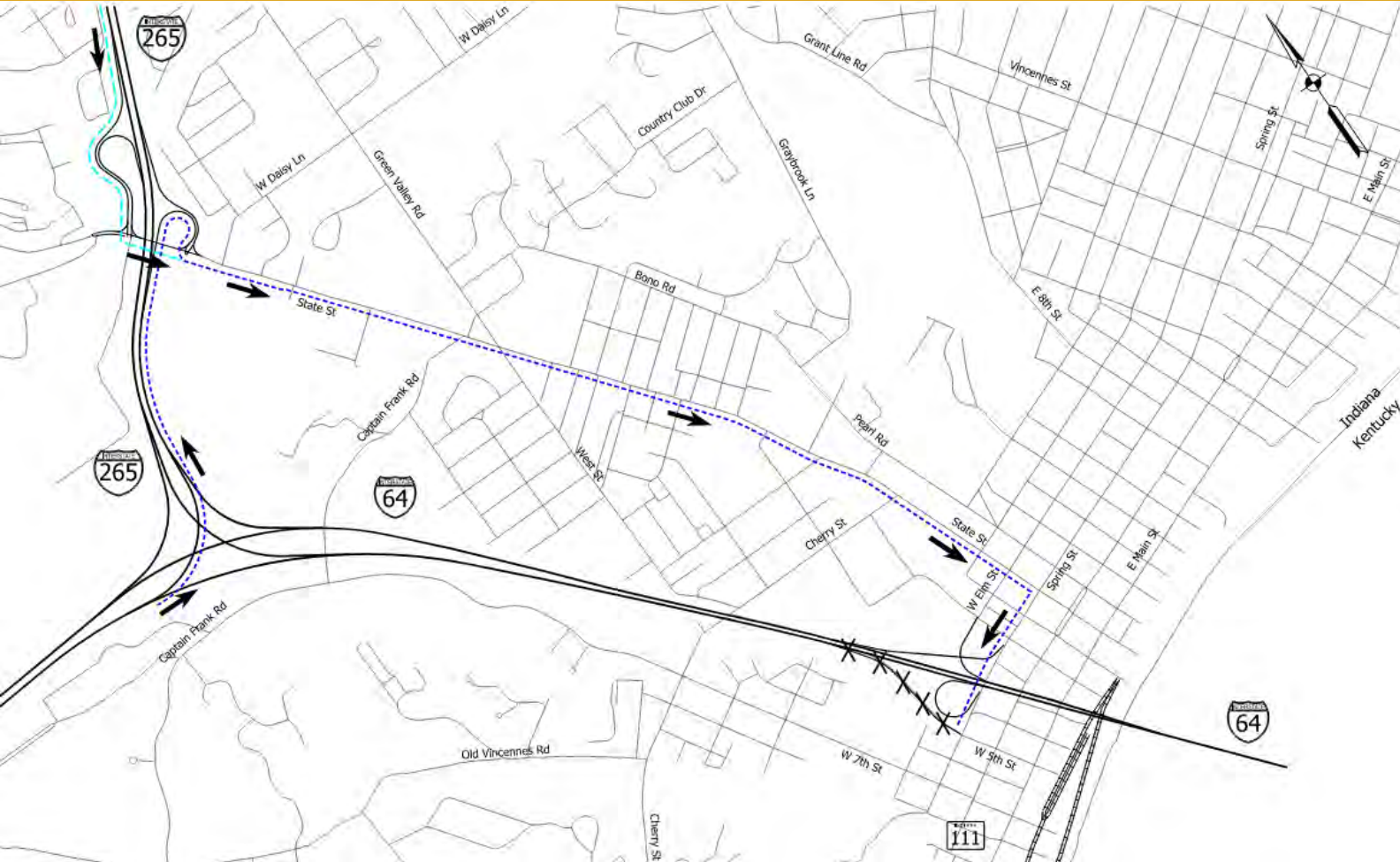

I-64 EB Exit Ramp to  
Spring Street Ramp  
Closure



# Detours

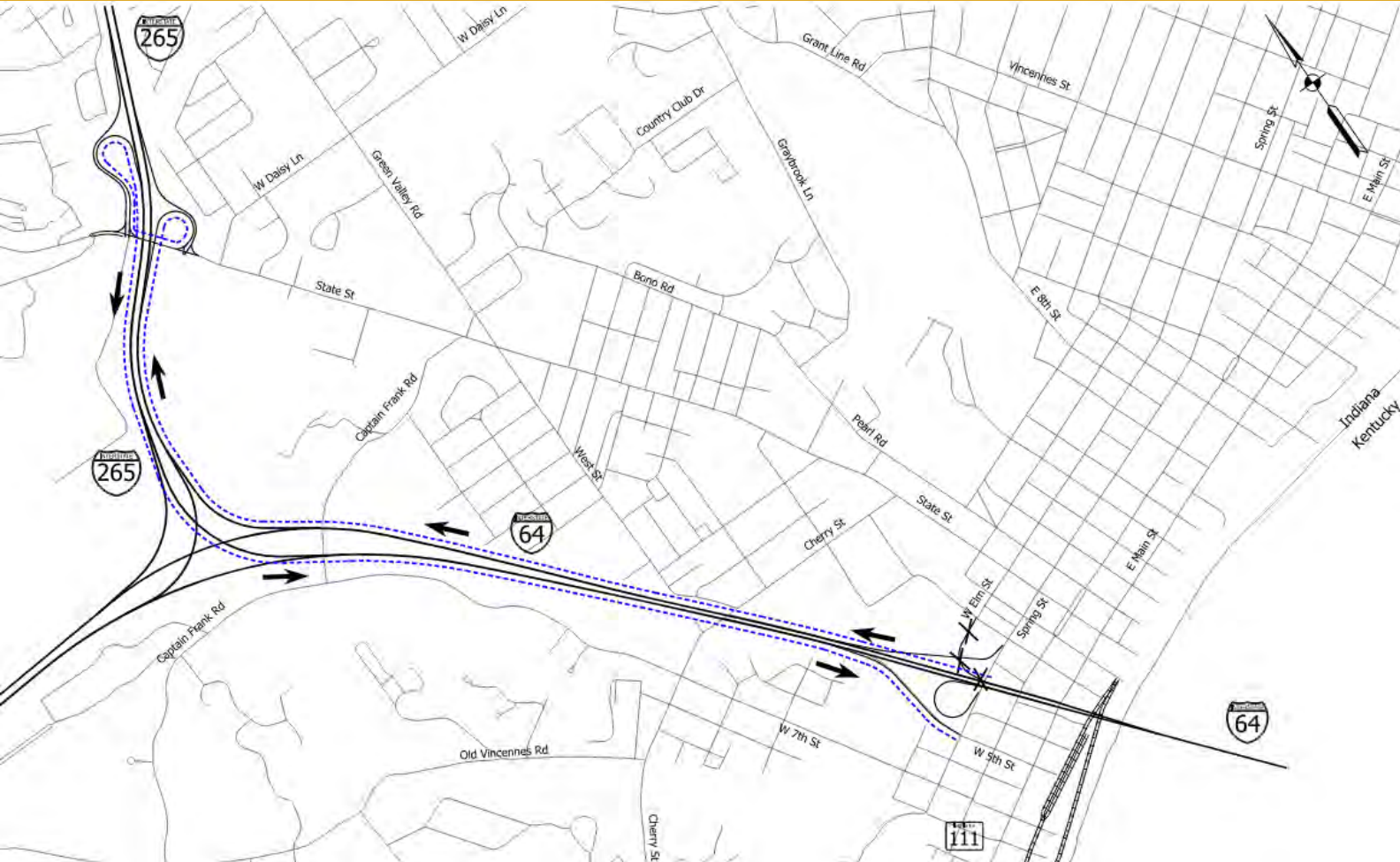

I-64 WB Exit Ramp to  
Spring Street Ramp  
Closure





# Detours

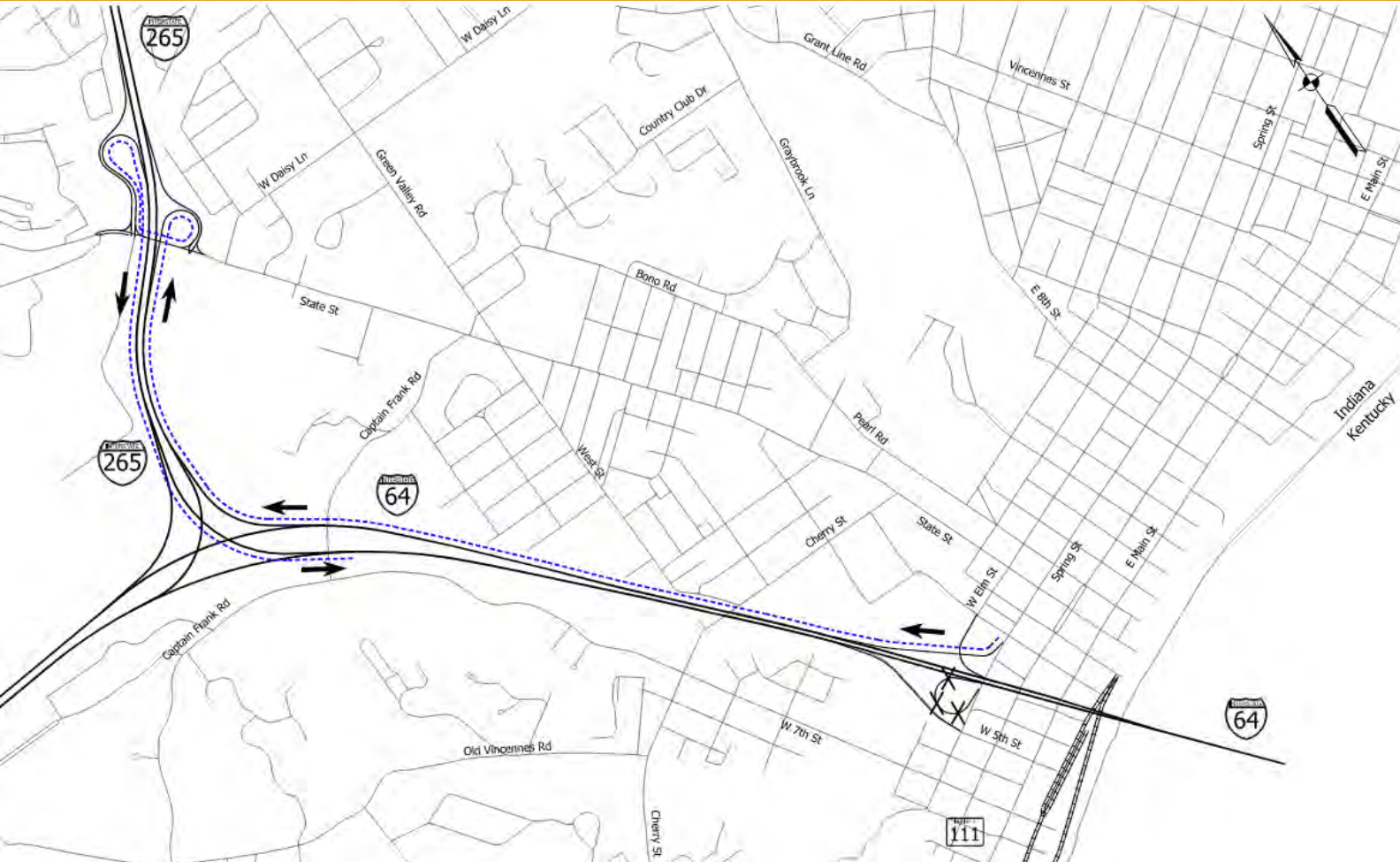

Spring Street Entrance  
Ramp to I-64 EB Ramp  
Closure



# Detours

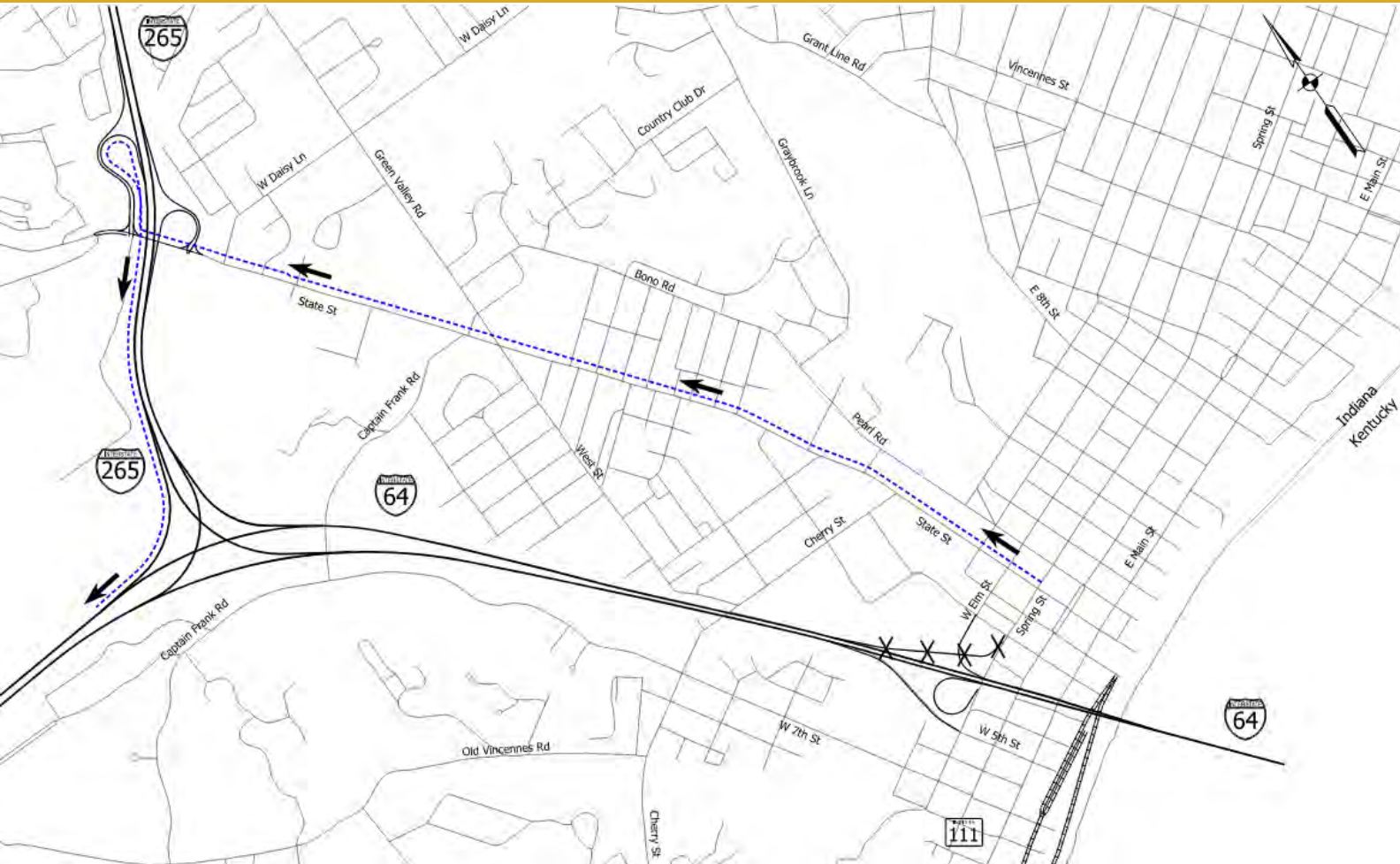

Spring Street Entrance  
Ramp to I-64 WB  
Ramp Closure

